

Mechanical Outline

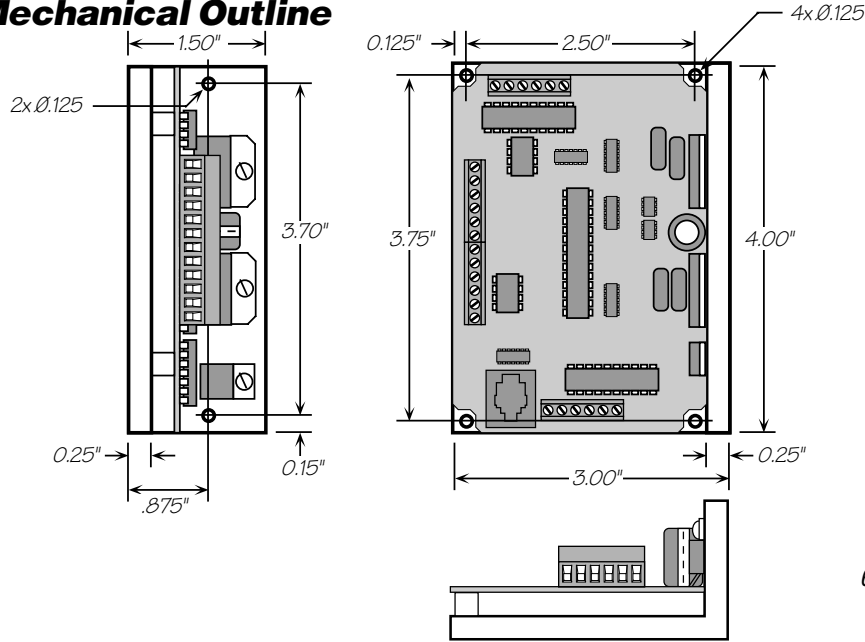

Connector Layout

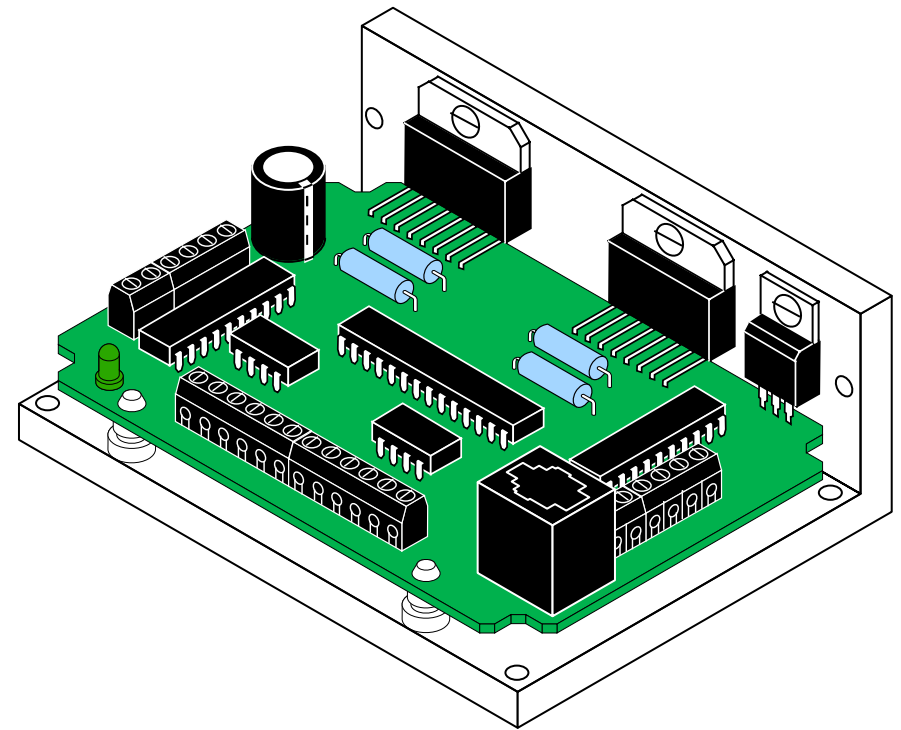
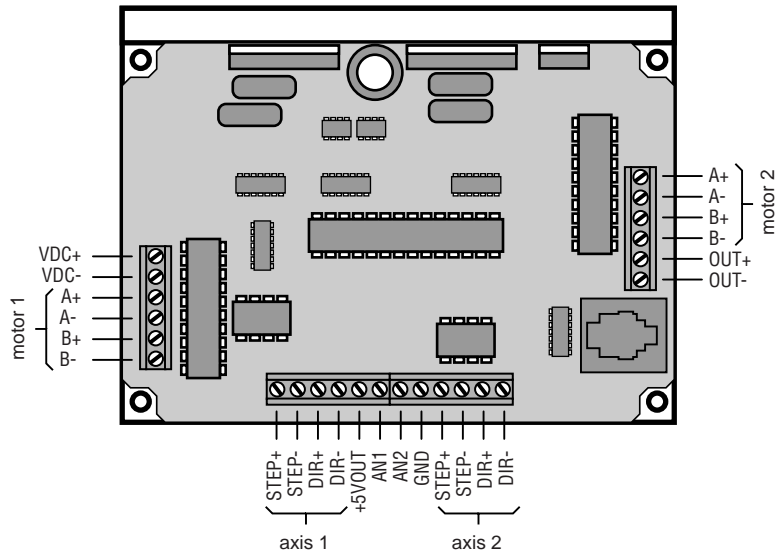

User's Manual

2035XD

Two Axis Step Motor Drive

Applied Motion Products, Inc.

404 Westridge Drive Watsonville, CA 95076

Tel (831) 761-6555 (800) 525-1609 Fax (831) 761-6544

**Applied
Motion
Products**
motors • drives • controls

Technical Specifications

Amplifiers Dual, bipolar H-bridge, pulse width modulated three state switching at 20.5kHz. 12-35 VDC input. 0.1 - 2.0 amps/phase output current, software selectable. 70 watts maximum output power per axis. Automatic idle current reduction (software selectable), reduces current when motor is not moving.

Digital Inputs Step/run 1, step/run 2, direction 1, direction 2. Differential, optically isolated, 5V logic. 440 ohms internal resistance. Motor steps on rising edge of STEP- input (and/or falling edge of STEP+). 0.5 μ sec minimum pulse width. 2 μ sec minimum set up time for direction signal.

Analog Inputs 0 to 5 VDC, 1K - 10K recommended impedance. 10 bit ADC.

Digital Output Optically isolated (photodarlington) 30VDC, 100 mA maximum

Physical Mounted on 1/4 inch thick black anodized aluminum heat transfer chassis. 1.5 x 3.0 x 4.0 inches overall. Power on green LED. See drawing on page 16 for more information. Ambient temperature range: 0 to 70° C.

Connectors European style screw terminal blocks. Wire size: AWG 16-28.
Motor 1 and DC input: 6 position (VDC+, VDC-, A+, A-, B+, B-)
Signal Input: 12 position (ST1+, ST1-, DR1+, DR1-, +5V, AN1, AN2, GND, ST2+, ST2-, DR2+, DR2-)
Motor 2 and Output: 6 position (A+, A-, B+, B-, OUT+, OUT-)

Microstepping 15 software selectable step resolutions. With 1.8° motor: 200, 400, 2000, 5000, 10000, 12800, 18000, 20000, 21600, 25000, 25400, 25600, 36000, 50000, 50800. Microstep waveform: pure sine.

12,800 steps/rev in run/stop mode.

Other resolutions available to qualified OEMs upon request.

Mounting the Drive

You can mount your drive on the wide or the narrow side of the chassis. If you mount the drive on the wide side, use #4 screws through the four corner holes. For narrow side mounting applications, you can use #4 screws in the two side holes.

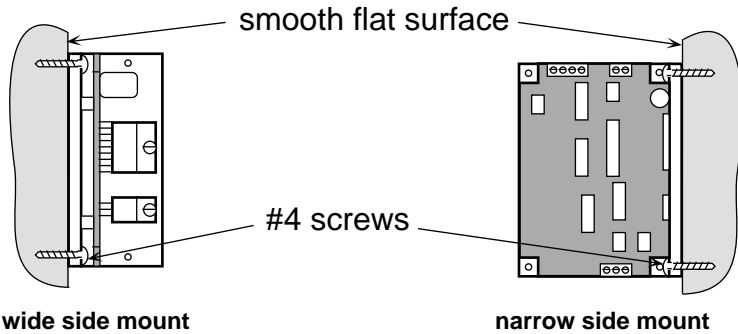

The amplifiers in the drive generate heat. To operate the drive for more than a few minutes you must properly mount it on a heat sinking surface. Applied Motion Products can provide a compatible heat sink. In most cases, securing the drive to the metal enclosure of your system will make an effective heat sink.

Never use your drive in a space where there is no air flow or where other devices cause the surrounding air to be more than 70 °C. Never put the drive where it can get wet or where metal particles can get on it.

Recommended Motors

Motor Number	Size inches	Winding Connection	Max Torque oz-in	Current Amps
HT11-012	1.1 x 1.1 x 1.32	4 lead	7	1.0
HT11-013	1.1 x 1.1 x 1.87	4 lead	15	1.0
5014-842	1.38 x 1.38 x 1.57	4 lead	22	1.0
HT17-068	1.65 x 1.65 x 1.30	parallel	31	1.3
HT17-071	1.65 x 1.65 x 1.54	parallel	51	1.7
HT17-075	1.65 x 1.65 x 1.85	parallel	62	1.7
HT23-394	2.22 x 2.22 x 1.54	parallel	54	2.0
HT23-397	2.22 x 2.22 x 2.13	parallel	125	2.0
HT23-400	2.22 x 2.22 x 2.99	parallel	187	2.0

Contents

Introduction	4
Features	4
Block Diagram	4
Getting Started	5
Connecting the Power Supply	6
Connecting the Motors	6
Connecting Logic	7
Step and Direction Signals	8
Run/Stop Signals	9
Connecting to the Analog Inputs	10
Programmable Output	11
Schematic Diagram of Output Circuit	11
Sinking Output	11
Sourcing Output	11
Microstepping	12
Choosing a Power Supply	13
Mounting the Drive	14
Recommended Motors	14
Technical Specifications	15
Mechanical Outline	16
Connector Layout	16

Introduction

Thank you for selecting an Applied Motion Products motor control. We hope our dedication to performance, quality and economy will make your motion control project successful.

If there's anything we can do to improve our products or help you use them better, please call or fax. We'd like to hear from you. Our phone number is (800) 525-1609 or you can reach us by fax at (831) 761-6544.

Features

- Two axis step motor driver in one compact package
- Drives sizes 11 through 23 step motors
- Pulse width modulation, 3 state switching amplifiers
- Phase current from 0.1 to 2.0 amps (set by software)
- Optically isolated, differential step/run, direction inputs
- 0 to 5 volt analog inputs for speed control
- 15 step resolutions, 200 - 50800 steps/rev (set by software)
- Automatic idle current reduction (set by software)

Block Diagram

(each axis)

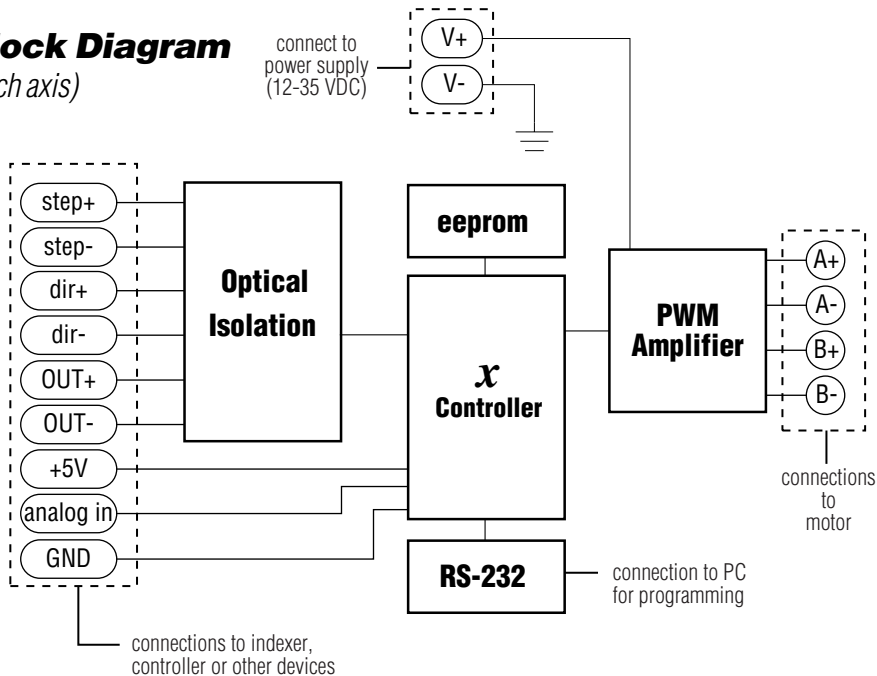

Choosing a Power Supply

Voltage

Chopper drives work by switching the voltage to the motor terminals on and off while monitoring current to achieve a precise level of phase current. To do this efficiently and silently, you'll want to have a power supply with a voltage rating at least five times that of the motor. Depending on how fast you want to run the motor, you may need even more voltage. More is better, the only upper limit being the maximum voltage rating of the drive itself: 35 volts (including ripple).

If you choose an unregulated power supply, make sure that the no load voltage does not exceed 35 volts DC. If the no load voltage is not specified, apply power to the supply without connecting the 2035XD and measure the voltage.

Current

The maximum supply current you will need is the sum of the two phase currents. However, you will generally need a lot less than that, depending on the motor type, voltage, speed and load conditions. That's because the 2035XD uses switching amplifiers, converting a high voltage and low current into lower voltage and higher current. The more the power supply voltage exceeds the motor voltage, the less current you'll need from the power supply.

We recommend the following selection procedure:

1. If you plan to use only a few drives, get a power supply with at least twice the rated phase current of the motor.
2. If you are designing for mass production and must minimize cost, get one power supply with more than twice the rated current of the motor. Install the motor in the application and monitor the current coming out of the power supply and into the drive at various motor loads. This will tell you how much current you really need so you can design in a lower cost power supply.

If you plan to use a regulated power supply you may encounter a problem with current foldback. When you first power up your drive, the full current of both motor phases will be drawn for a few milliseconds while the stator field is being established. After that the amplifiers start chopping and much less current is drawn from the power supply. If your power supply thinks this initial surge is a short circuit it may "foldback" to a lower voltage. With many foldback schemes the voltage returns to normal only after the first motor step and is fine thereafter. In that sense, unregulated power supplies are better. They are also less expensive.

The PS430 from Applied Motion Products is a good supply to use with the 2035XD.

Microstepping

Many step motor drives offer a choice between full step and half step resolutions. In most full step drives, both motor phases are used all the time. Half stepping divides each step into two smaller steps by alternating between both phases on and one phase on. Microstepping drives like the 2035XD precisely control the amount of current in each phase at each step position as a means of electronically subdividing the steps even further. The 2035XD offers a choice of full step, half step and 13 microstep resolutions. The highest setting divides each full step into 254 microsteps, providing 50,800 steps per revolution when using a 1.8° motor.

In addition to providing precise positioning and smooth motion, microstep drives can be used to provide motion in convenient units. When the drive is set to 2000 steps/rev (1/10 step) and used with a 5 pitch lead screw, you get .0001 inches/step.

The step resolution is selected using the eXposition™ software on your PC.

Restrictions:

If an axis is in run/stop mode, the resolution of that axis is automatically 12,800 steps/rev.

If one axis is set for full step (200 steps/rev) or half step (400 steps/rev) then the other axis must be also set for 200 or 400 steps/rev.

Direction signal must be set at least 10 microseconds before activating the run signal, or the move may take place in the wrong direction.

Getting Started

To use your Applied Motion Products motor control, you will need the following:

- a 12-35 volt DC power supply for the motor. Please read the section entitled Choosing a Power Supply for help in choosing the right power supply.
- a compatible step motor.
- a small flat blade screwdriver for tightening the connectors (included with drive).
- a personal computer running Microsoft Windows 95, 98, NT, Me, 2000 or XP.
- Applied Motion's eXposition™ software (supplied with drive on CD)
- Applied Motion Si™ programming cable.

If you plan to use the drive in Pulse & Direction Mode:

- a source of step pulses. Signal may be sinking (NPN), sourcing (PNP) or differential.
- if your application calls for bidirectional rotation, you'll also need a direction signal. This signal may also be sourcing, sinking or differential.

For Oscillator Mode:

- A run/stop signal or switch and a direction signal or switch. Signals may be sinking (NPN), sourcing (PNP) or differential.
- Analog speed signal or speed control potentiometer (optional)

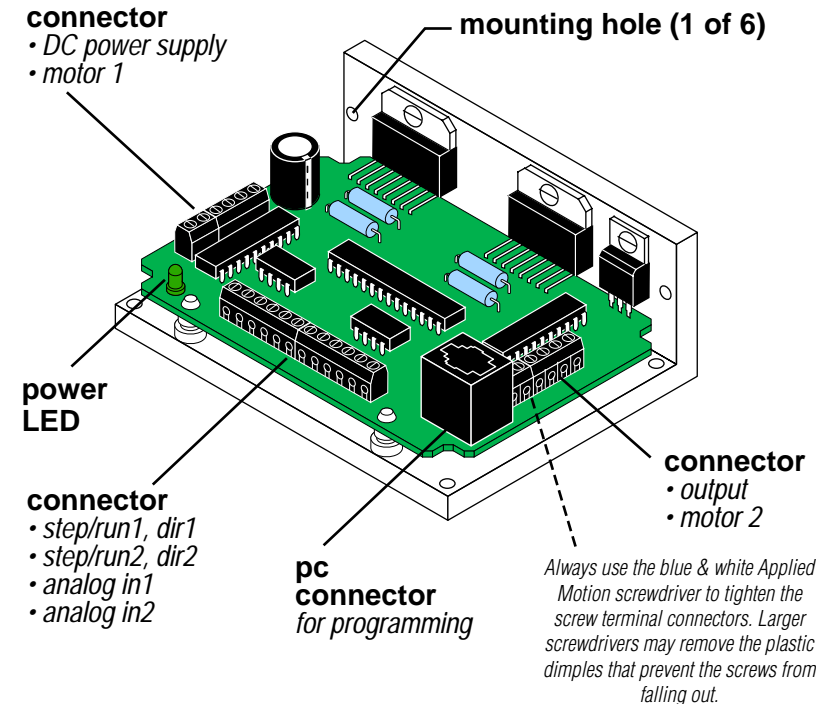

Connecting the Power Supply

If you need information about choosing a power supply, please read Choosing a Power Supply located on page 13 of this manual. The PS430 from Applied Motion Products is a good supply for this drive.

If your power supply does not have a fuse on the output or some kind of short circuit current limiting feature you need to put a 4 amp fast acting fuse between the drive and power supply. Install the fuse on the + power supply lead.

Connect the motor power supply "+" terminal to the driver terminal labeled "+ VDC". Connect power supply "-" to the drive terminal labeled "VDC-". Use no smaller than 20 gauge wire. Be careful not to reverse the wires. Reverse connection will destroy your driver, void your warranty and generally wreck your day.

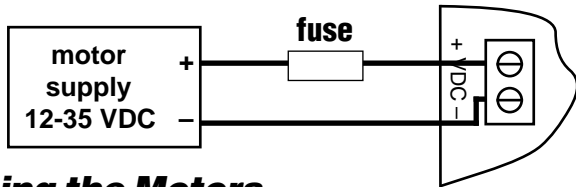

Connecting the Motors

Warning: When connecting a motor to the driver, be sure that the motor power supply is off. Secure any unused motor leads so that they can't short out to anything. Never disconnect the motor while the drive is powered up. Never connect motor leads to ground or to a power supply!

You must now decide how to connect your motor to the drive.

Four lead motors can only be connected one way. Please follow the sketch at the right.

Six lead motors can be connected in series or center tap. In series mode, motors produce more torque at low speeds, but cannot run as fast as in the center tap configuration. In series operation, the motor should be operated at 30% less than rated current to prevent overheating. Wiring diagrams for both connection methods are shown on the next page. NC means not connected to anything.

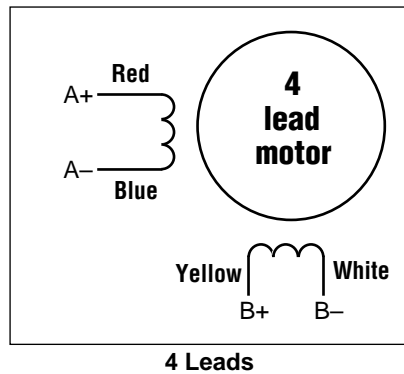

Programmable Output

The programmable output can be used to drive an LED, relay or the input of another electronic device like a PLC or counter. The "+" (collector) and "-" (emitter) terminals of the phototransistor are available at the connector. This allows you to configure the output for current sourcing or sinking. Diagrams of each type of connection are shown below.

Do not connect the output to more than 30VDC.

The current through the output terminals must not exceed 20 mA.

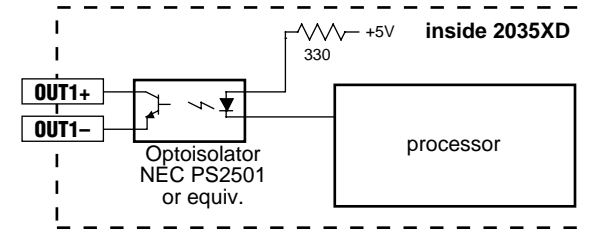

Schematic Diagram of Output Circuit

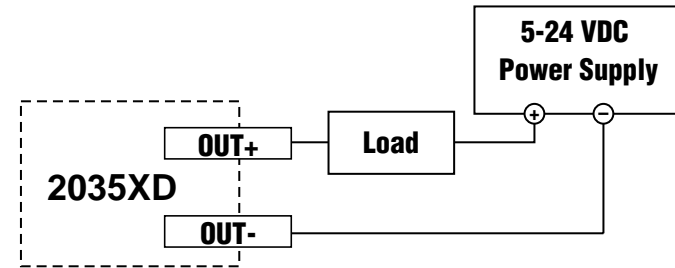

Sinking Output

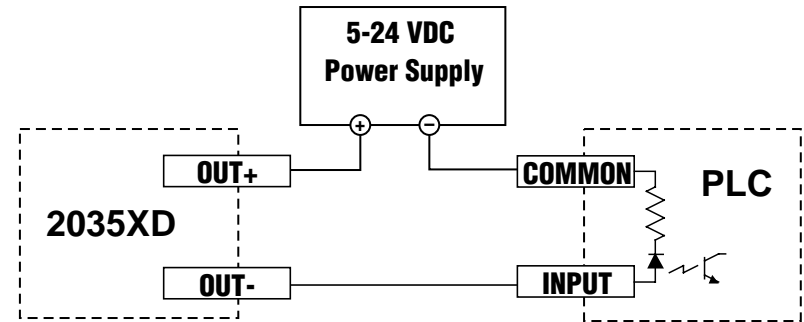

Sourcing Output

Connecting to the Analog Inputs

The analog input of each axis can be used to control the motor speed when that axis is programmed for oscillator mode. The speed may also be fixed and the analog input ignored and left unconnected.

+5 volt DC is provided for powering potentiometers. A 1000 to 10000 ohm potentiometer is recommended and should be connected as shown below.

The +5V terminal is an output. Do not connect it to a power supply.

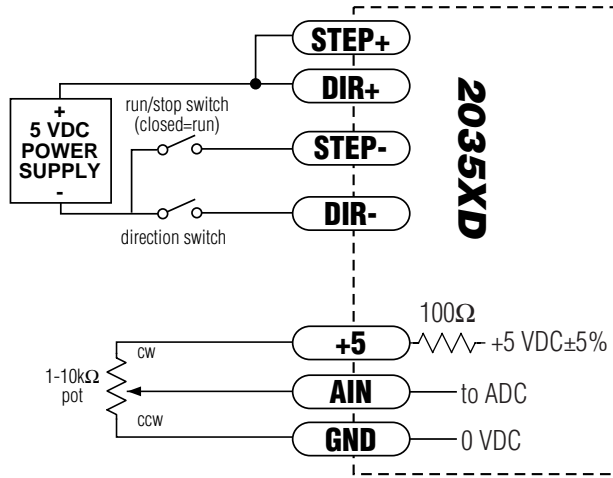

Connecting an Analog Input to a Potentiometer

A 0 to 5 volt analog signal may also be used. Usually this signal comes from a PLC, a PC with data acquisition card or a motion controller. Connections are shown below.

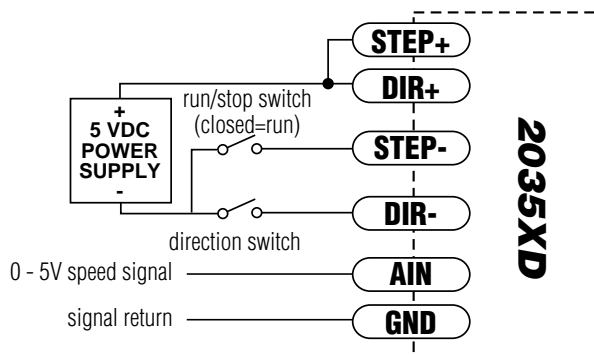

Connecting an Analog Input to an Active Signal

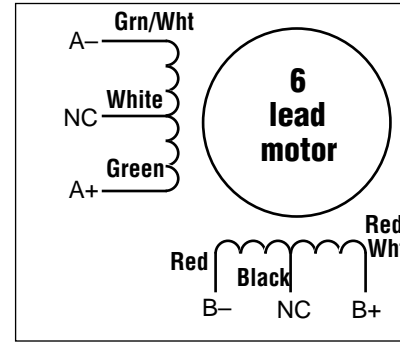

6 Leads Series Connected

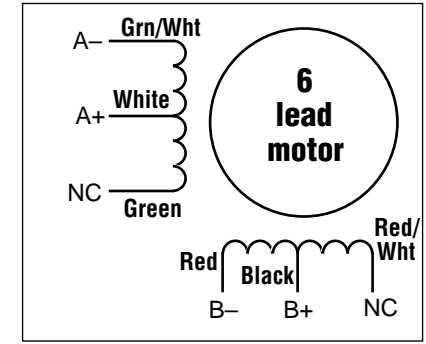

6 Leads Center Tap Connected

Eight lead motors can also be connected in two ways: series or parallel. As with six lead motors, series operation gives you more torque at low speeds and less torque at high speeds. In series operation, the motor should be operated at 30% less than the rated current to prevent over heating. The wiring diagrams for eight lead motors are shown below.

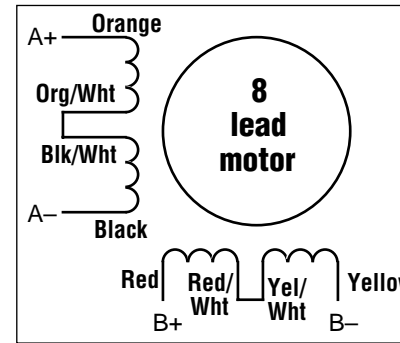

8 Leads Series Connected

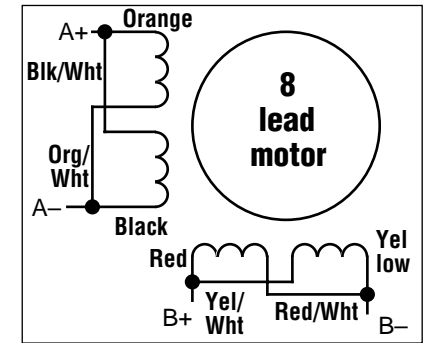

8 Leads Parallel Connected

Connecting Logic

The 2035XD contains optical isolation circuitry to prevent the electrical noise inherent in switching amplifiers from interfering with your circuits. Optical isolation is accomplished by powering the motor driver from a different supply than your circuits. There is no electrical connection between the two: signal communication is achieved by infrared light. When your circuit turns on or turns off an infrared LED (built into the drive) it signals a logic state to the phototransistors that are wired to the brains of the drive. A schematic diagram of the input circuit is shown at the right.

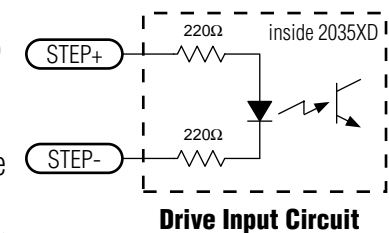

Step and Direction Signals

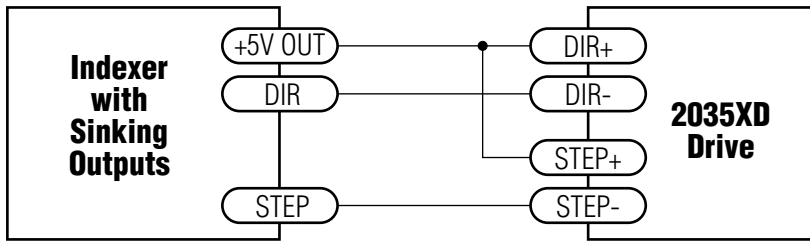

Connecting to Indexer with Sinking Outputs
(includes Applied Motion Si-1 Indexer)

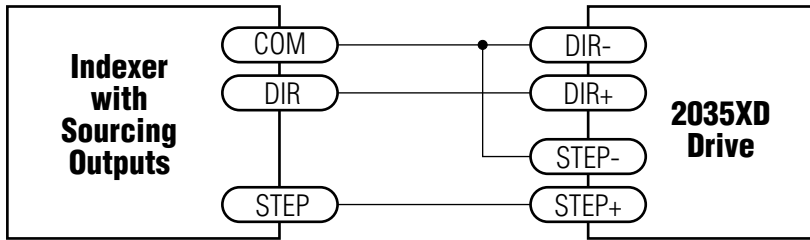

Connecting to indexer with Sourcing Outputs

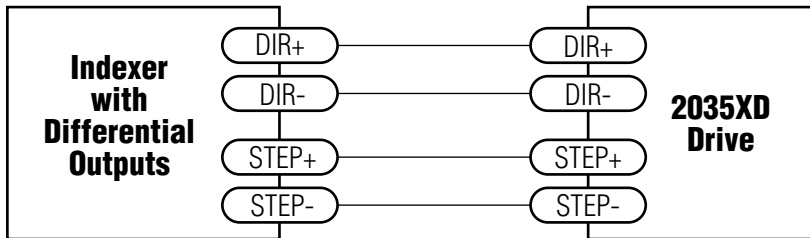

Connecting to Indexer with Differential Outputs
(Many High Speed Indexers have Differential Outputs)

Run/Stop Signals

Most PLCs, don't use 5 volt logic. You can connect signal levels as high as 24 volts to the 2035XD if you add external dropping resistors to the STEP and DIR inputs, as shown below.

- For 12 volt logic, add 820 ohm, 1/4 watt resistors
- For 24 volt logic, use 2200 ohm, 1/4 watt resistors

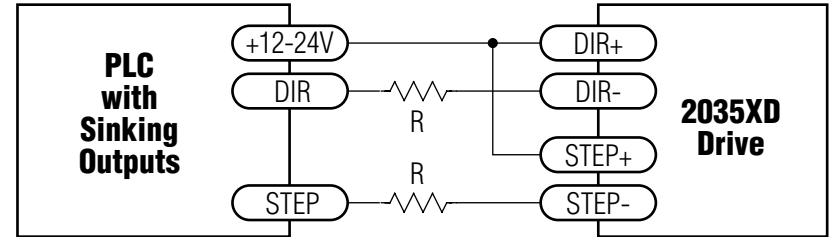

Connecting to PLC with Sinking (NPN) Outputs
(Most PLC's use 24 volt logic)

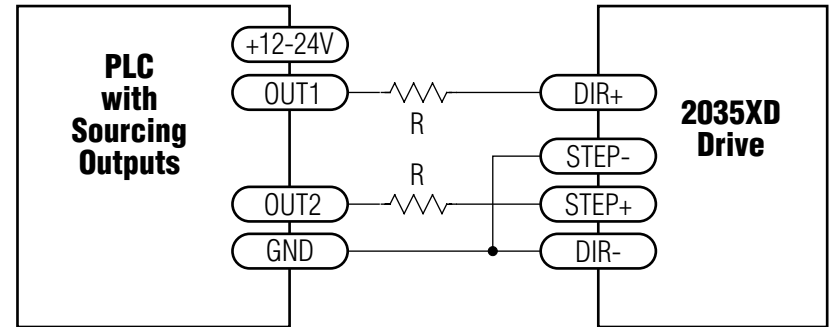

Connecting to PLC with Sourcing (PNP) Outputs
(Most PLC's use 24 volt logic)

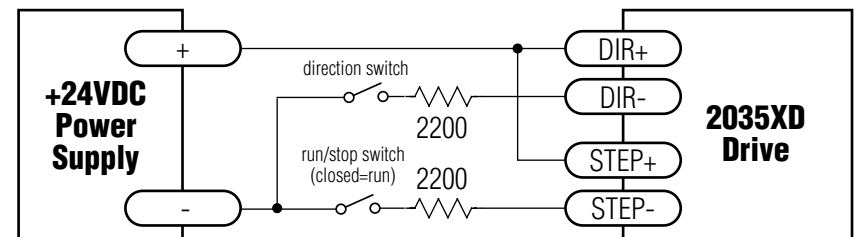

Using Mechanical Switches to Control Run/Stop and Direction