

# Hardware Manual

## Si3540

### Programmable Step Motor Driver

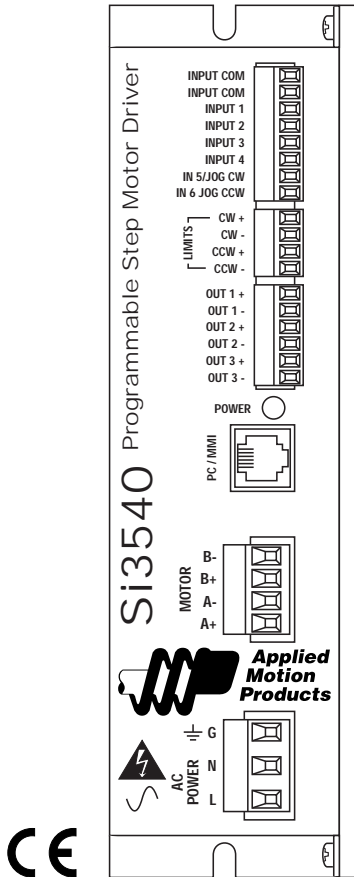

# Table of Contents

Introduction .....	3
Features .....	3
Block Diagram .....	3
Getting Started .....	4
Connecting the AC Line .....	5
Connecting the Motor .....	7
Connecting to the PC .....	8
Jogging .....	9
Limit Switches .....	9
Wiring a Mechanical Limit Switch .....	10
Wiring a Limit Sensor .....	10
Wiring Inputs .....	11
Wiring Outputs .....	13
Microstepping .....	14
Mounting the Drive .....	15
Mounting the Optional MMI .....	15
Recommended Motors .....	17
Mechanical Outline .....	17
Technical Specifications .....	18
Mechanical Outline - Optional MMI .....	19

# Introduction

Thank you for selecting an Applied Motion Products motor control. We hope our dedication to performance, quality and economy will make your motion control project successful. If there's anything we can do to improve our products or help you use them better, please call or fax. We'd like to hear from you. Our phone number is (800) 525-1609 or you can reach us by fax at (831) 761-6544.

# Features

- Powerful, precise and efficient MOSFET driver providing up to 3.5 amps per phase and microstepping to 50,800 steps per revolution.
- Reliable, efficient, low noise 40 VDC linear, toroidal power supply.
- Powerful, flexible, easy to use indexer.
- Connects by a simple cable to your PC for programming (cable included).
- Microsoft Windows™-based software for easy setup and programming
- Eight inputs for interacting with the user and other equipment.
- Three outputs for coordinating external equipment.
- Accepts 110 or 220 volt AC power (factory preset for 110 volts).
- External trigger I/O is optically isolated, 5-24V, sinking or sourcing signals. PC/MMI port is RS-232.
- Sturdy 2.25 x 7.8 x 5 inch metal chassis.
- Pluggable screw terminal connectors for motor, AC power and I/O signals.
- Optional man machine interface (MMI) allows operator to enter distances, speeds, cycle counts and more.
- CE and TUV Compliant

# Block Diagram

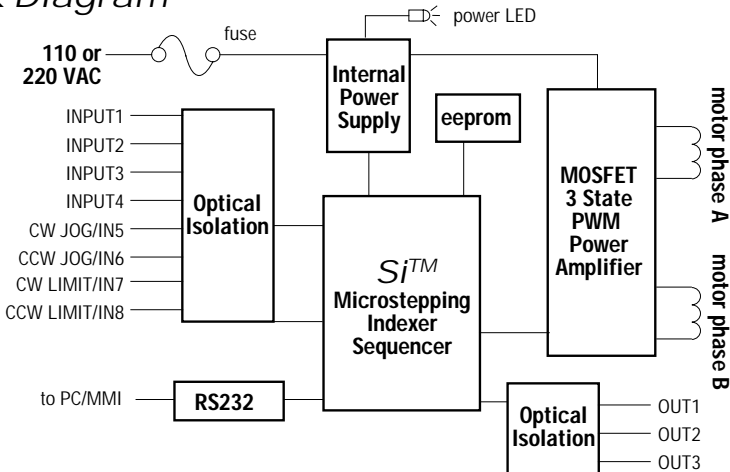

# Getting Started

To use your Si3540 motor control, you will need the following:

- ✓ a power cable (line cord)
- ✓ a compatible step motor
- ✓ a small flat blade screwdriver for tightening the connectors - an Applied Motion Products screwdriver suitable for this purpose is included with your drive.
- ✓ a personal computer running Windows 3.1, 95, 98 or NT with a 9 pin serial port (486 or better with 8 MB ram recommended)
- ✓ the Si Programmer™ software that came with your Si3540
- ✓ the programming cable that came with your Si3540
- ✓ Si Programmer™ software manual

The sketch below shows where to find the important connection and adjustment points. Please examine it now.

## All Mating connectors included.

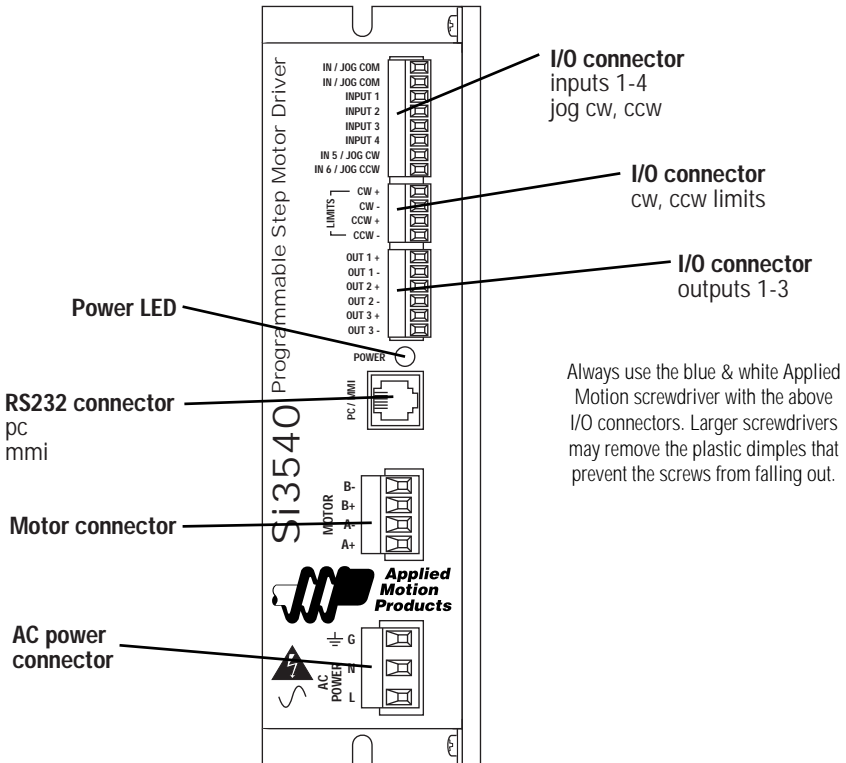

## Connecting the AC Line

The Si3540 is set for 110 VAC operation at the factory. If you use **110 VAC** power, all you need to do is install a power cord and plug it in. If you plan to use **220 VAC** power, follow the instructions below.

*Note: If you plan to hard wire the Si3540 to AC power, consult a qualified electrician and observe all building and electrical codes. AC power can be dangerous.*

### 220 VAC Instructions

In order to use 220 volts, you'll need to change a fuse and a switch setting inside the case.

- Remove all mating connectors from the drive.
- Set the drive on it's widest side, so that you can read *Si3540 Programmable Step Motor Driver* properly.
- Remove the four (4) phillips head screws that mount the chassis sheet metal to the chassis heat sink. See page 17 for a mechanical outline of the drive.
- The 110/220 switch is located near the position of the AC power connector, next to the toroidal transformer (see sketch below).
- For 220 VAC operation slide the switch towards the bottom of the drive, or towards the transformer end of the drive. The position of the switch is labeled on the PC board also, "230" being for 200-240 VAC operation, and "115" for 100-120 VAC operation.
- Replace the fuse next to the switch with the 220 VAC fuse that came with the drive. See technical specifications on page 18 to order more fuses.
- Replace the drive's cover and assembly screws.

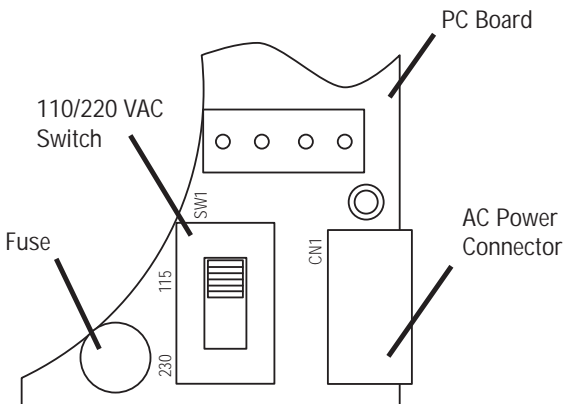

Switch set for 110 VAC

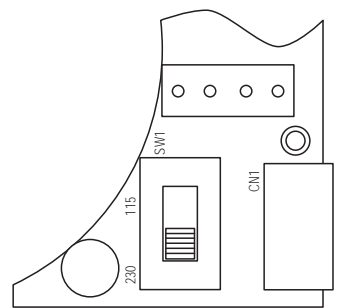

Switch set for 220 VAC

## Installing an AC Line Cord

Remove about 5 mm (3/16 inches) of insulation from each of the three wires of your line cord. (That's right, three wires. For safety, always use a three wire power cord on anything with a metal case). Depending on where you got your power cord, it may have black, white and green wires, or brown, white and green wires.

The AC power plug that was shipped with your Si3540 might be one of two types. The "old style" is shown below, on the left. The "new style", which comes with an insulating rubber boot, is shown below, on the right.

***Make sure you follow the proper sketch for your connector style.***

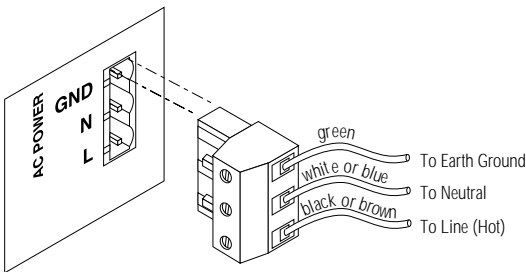

**"Old Style"  
AC Power Plug**

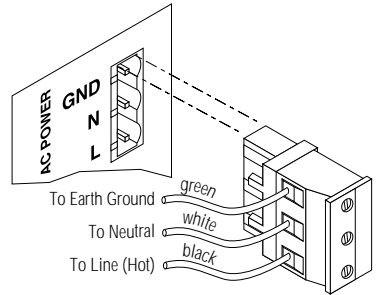

**"New Style"  
AC Power Plug**



***Always unplug the line cord from the wall before attaching it to the Si3540.***

- Connect the black or brown wire to the Si3540 "L" terminal of the AC power connector. That is the line, or "hot" connection.
- Connect the white or blue wire to neutral, the "N" terminal.
- Finally, and most importantly, connect the green wire to the "GND" terminal. That connects the Si3540 metal enclosure and DC power supply ground to earth ground.

## Connecting the Motor



**Never connect or disconnect the motor to the driver when the AC power is on.**

**Secure any unused motor leads.**

**Never disconnect the motor while the AC power is on.**

**Never connect motor leads to ground or to a power supply.**

You must now decide how to connect your motor to the drive.

**Four lead motors** can only be connected one way. Please follow the sketch at the right.

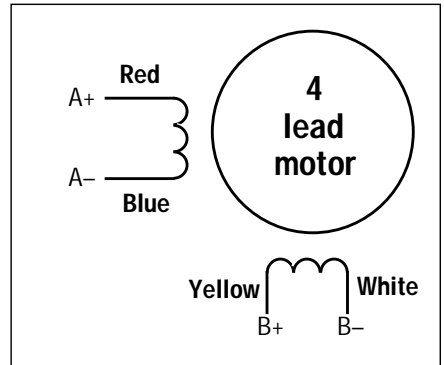

4 Leads

**Six lead motors** can be connected in series or center tap. In series mode, motors produce more torque at low speeds, but cannot run as fast as in the center tap configuration. In series operation, the motor should be operated at 30% less than the rated current to prevent overheating. Wiring diagrams for both connection methods are shown below.

*Note: NC means not connected to anything.*

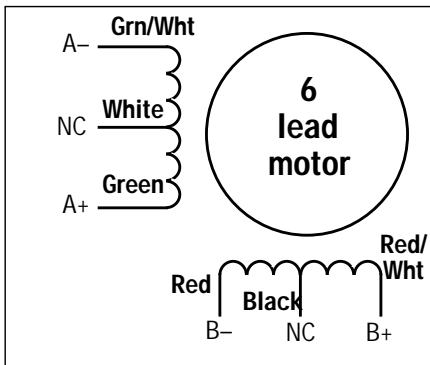

6 Leads Series Connected

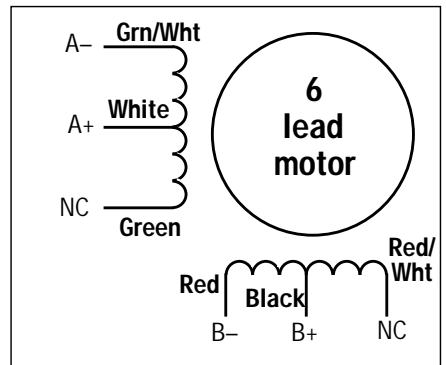

6 Leads Center Tap Connected

**Eight lead motors** can also be connected in two ways: series and parallel. As with six lead motors, series operation gives you more torque at low speeds and less torque at high speeds. In series operation, the motor should be operated at 30% less than the rated current to prevent overheating. The wiring diagrams for eight lead motors are shown below.

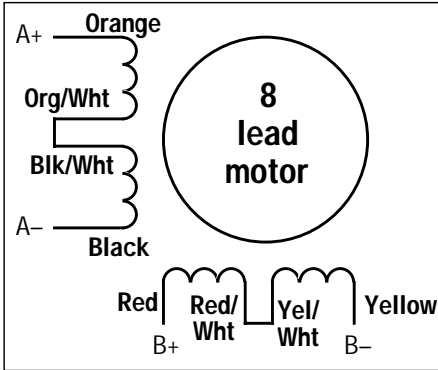

**8 Leads Series Connected**

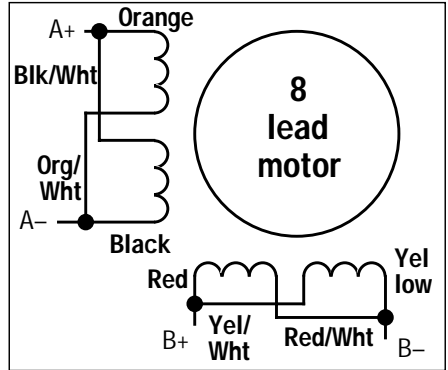

**8 Leads Parallel Connected**

### *Connecting to the PC*

- Locate your computer within 6 feet of the Si3540.
- Your Si3540 was shipped with a black adapter plug. It has a telephone style jack at one end and a larger 9 pin connector at the other. Plug the large end into the COM1 serial port of your PC. Secure the adapter with the screws on the sides. If the COM1 port on your PC is already used by something else, you may use the COM2 port for the Si3540. On some PCs, COM2 will have a 25 pin connector that does not fit the black adapter plug. If this is the case, and you must use COM2, you may have to purchase a 25 to 9 pin serial adapter at your local computer store.
- Your Si3540 was also shipped with a 7 foot telephone line cord. Plug one end into the adapter we just attached to your PC, and the other end into the PC/MMI jack on your Si3540.



***Never connect the Si3540 to a telephone circuit. It uses the same connectors and cords as telephones and modems, but the voltages are not compatible.***

*Programming Note: Always apply power to the Si3540 after the Si™ Programmer software is running on your PC.*

## Jogging

Two of the Si3540 input terminals are provided for jogging the motor. The inputs are labeled "JOG CW" and "JOG CCW". Activating one of the inputs commands the drive to move the motor at a pre-designated speed until the contact is opened. A relay or mechanical switch can be used to activate the jog inputs. 5-24 volt circuitry can be used. The schematic diagram of the input circuit is shown below.

If you're using a switch or relay, wire one end to the JOG input and the other to the power supply negative (-) terminal. Then connect the COM input to the power supply positive (+) terminals.

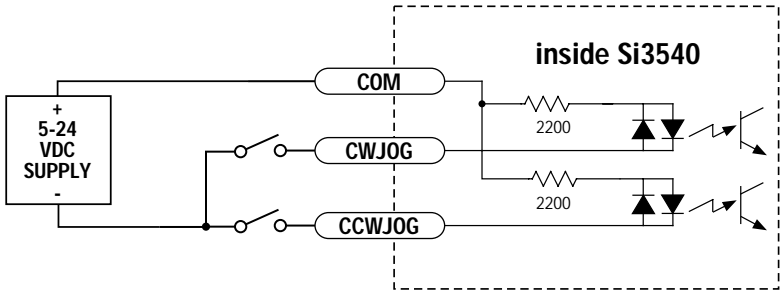

## Limit Switches

The Si3540 has two limit switch inputs, LIMIT CW and LIMIT CCW. By connecting switches or sensors that are triggered by the motion of the motor or load, you can force the Si3540 to operate within certain limits. This is useful if a program error could cause damage to your system by traveling too far.

The limit inputs are optically isolated. This allows you to choose a voltage for your limit circuits of 5 to 24 volts DC. This also allows you to have long wires on limit sensors that may be far from the Si3540 with less risk of introducing noise to the Si3540. The schematic diagram of the limit switch input circuit is shown below.

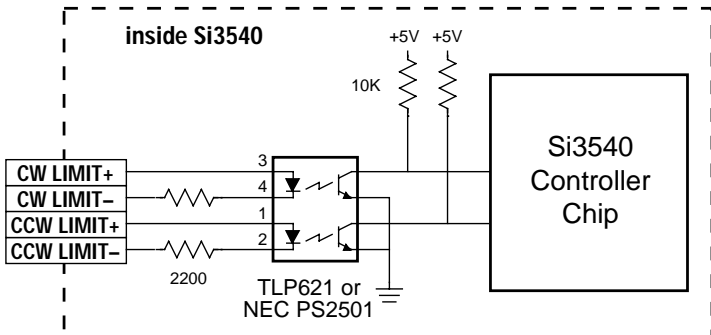

## Wiring a Mechanical Limit Switch

You can use normally open or normally closed limit switches. Either way, wire them as shown here.

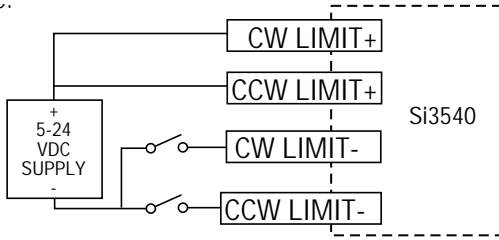

## Wiring a Limit Sensor

Some systems use active limit sensors that produce a voltage output rather than a switch or relay closure. These devices must be wired differently than switches.

If your sensor has an open collector output or a **sinking** output, wire it like this:

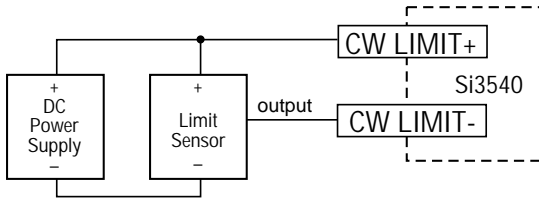

### Wiring for Sinking or Open Collector Output

If the sensor output goes low at the limit, select the option "closed". If the output is open, or high voltage, choose "open".

Other sensors have **sourcing** outputs. That means that current can flow out of the sensor output, but not into it. In that case, wire the sensor this way:

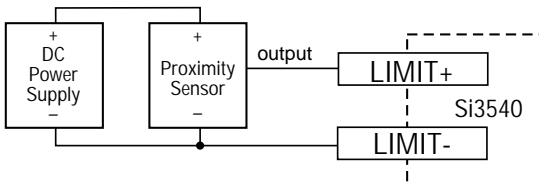

### Wiring for Sourcing Output

If the sensor output goes high at the limit, choose the program option "closed". If the output is low at the limit, select "open".

## Wiring Inputs

The Si3540 input circuits can be used with sourcing or sinking signals, 5 to 24 volts. This allows connection to TTL circuits, PLCs, relays and mechanical switches. Because the input circuits are isolated, they require a source of power. If you are connecting to a TTL circuit or to a PLC, you should be able to get power from the PLC or TTL power supply. If you are using relays or mechanical switches, you will need a 5-24 power supply. This also applies if you are connecting the Si3540 inputs to another Si product from Applied Motion, like the Si-1 and Si-100 indexers or the Si5580, 7080i and MC8400 indexer-drives.

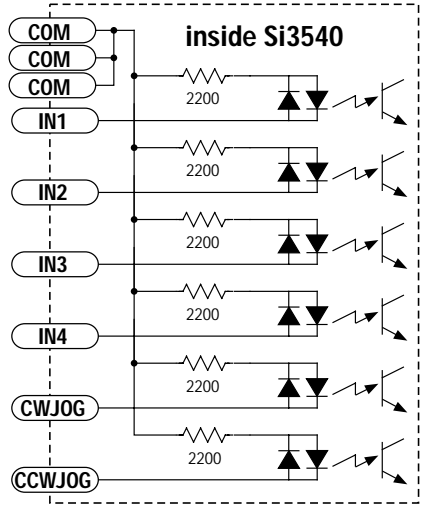

*Note: If current is flowing into or out of an Si3540 input, the logic state of that input is low. If no current is flowing, or the input is not connected, the logic state is high.*

The diagrams on the following pages show how to connect Si3540 inputs to various devices.



**The maximum voltage that can be applied to an input terminal is 24 volts DC. Never apply AC voltage to an input terminal.**

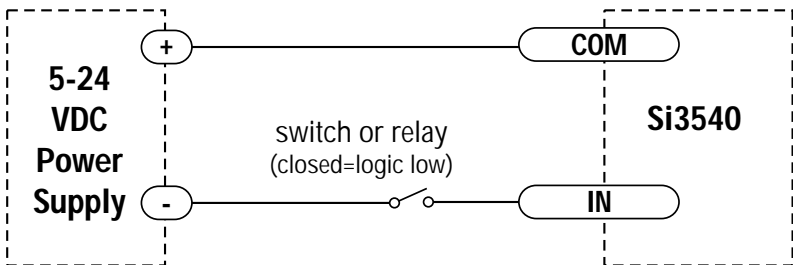

### Connecting an Input to a Switch or Relay

Use normally open momentary switch to trigger Si3540 using Wait Input instruction.

Use single throw switch for parameter selection using If Input instruction.

Use normally open momentary switch for jogging.

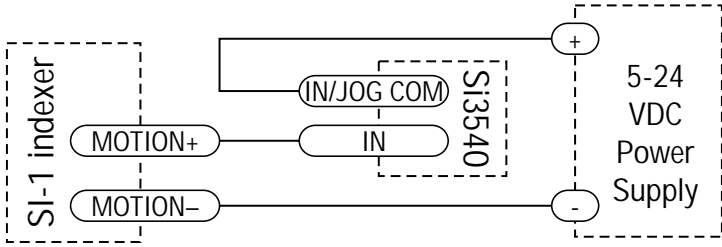

**Connecting an Input to the Si-1 Motion Output**

(Set Si-1 motion signal to "in position". Si-1 will trigger Si3540 at end of each move).

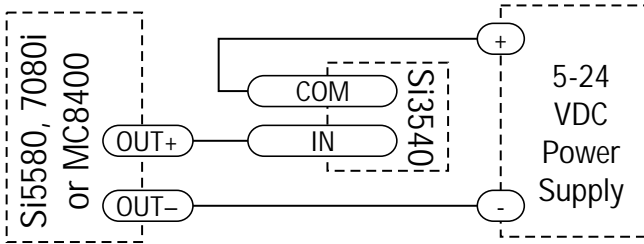

**Connecting a 3540i, Si5580, 7080i or MC8400**

(When output closes, Si3540 input goes low).

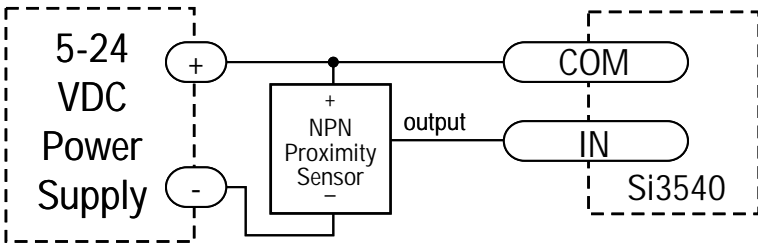

**Connecting an NPN Type Proximity Sensor to an Si3540 input**

(When prox sensor activates, Si3540 input goes low).

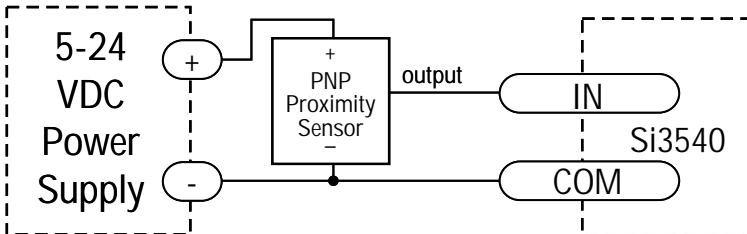

**Connecting a PNP Type Proximity Sensor to an Si3540 input**

(When prox sensor activates, Si3540 input goes low).

## Wiring Outputs

Before we discuss the output conditions, we need to talk about the circuitry. All three Si3540 outputs are optically isolated. That means that there is no electrical connection between the indexer-drive and the output terminals. The signal is transmitted to the output as light. What you “see” is a transistor (NPN type) that closes, or conducts current, when the output is “low”. When the output is high, the transistor is open.

*Note: At power-up, the Si3540 sets all three programmable outputs high (open circuit).*



**The maximum voltage between any pair of + and - output terminals is 24 volts DC. Never connect AC voltages to the Si3540 output terminals. Maximum current is 100 mA per output.**

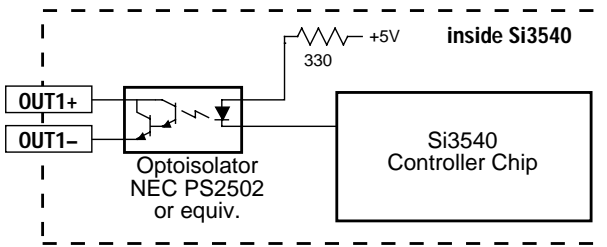

**Schematic Diagram of Si3540 Output Circuit**

Since there is no electrical connection to the Si3540, you must provide the source of current and voltage, typically from a power supply. You must also limit the current to less than 100 mA so that the output transistor is not damaged. You would normally use a resistor for this, but some loads (such as PLC inputs) limit the current automatically.

The diagram below shows how to connect an Si3540 output to an optically isolated PLC input.

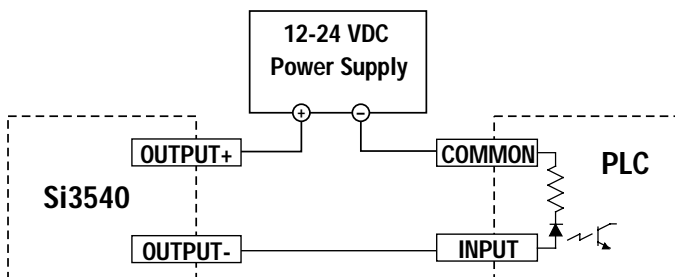

## *Microstepping*

Most step motor drives offer a choice between full step and half step resolutions. In full step mode, both motor phases are used all the time. Half stepping divides each step into two smaller steps by alternating between both phases on and one phase on.

Microstepping drives like the Si3540 precisely control the amount of current in each phase at each step position as a means of electronically subdividing the steps even further. The Si3540 offers a choice of 13 step resolutions. The highest setting divides each full step into 254 microsteps, providing 50,800 steps per revolution when using a  $1.8^\circ$  motor.

In addition to providing precise positioning and smooth motion, microstep drives can be used for motion conversion between different units. The 25,400 step/rev setting is provided as a means of converting motion from metric to english (there are 25.4 mm in an inch). Other settings provide step angles that are decimal degrees (36,000 steps/rev makes the motor take  $0.01^\circ$  steps). Some settings are used with lead screws. When the drive is set to 2000 steps/rev and used with a 0.2 pitch lead screw, you get 0.0001 inches/step.

The microstep resolution of the Si3540 is set by the Si Programmer™ software.

## Mounting the Drive.

You can mount your drive on the wide or the narrow side of the chassis.

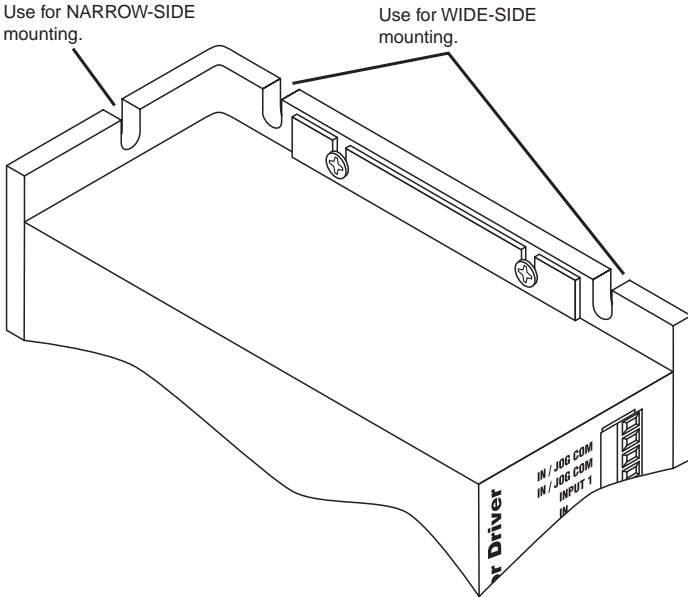

***Never use your drive in a space where there is no air flow or where the ambient temperature exceeds 50C (120F).***

***Never put the drive where it can get wet.***

***Never allow metal particles near the drive.***

## Mounting the Optional MMI

There are two ways to mount the MMI in your application. No matter which method you choose, you'll need to connect the MMI to your Si3540 with the programming cable. You will not, however, need the adapter plug. The MMI has the same telephone style connector as the Si3540.

Depending on how you mount the MMI and cable in your application, you may find that it is difficult to remove the cable from the back of the MMI. If this is the case, and you need to reprogram the Si3540, you can use any telephone line cord as a programming cable. They are available at most supermarkets and discount stores. Please be careful not to lose the adapter plug that connects the telephone cord to the COM port of your PC. The adapter is a custom made part and is only available from Applied Motion.

## Flush Mounting

When you remove the MMI from the shipping carton, you will notice that it has two parts. The first is a fairly thin section that contains the keypad, display and some circuit boards. The other part is thicker and contains the telephone jack and a cable that connects to the keypad assembly.

When you flush mount the MMI in a panel, only the thin section will stick out from your panel - the large portion mounts behind your panel. You'll need to cut a precise section from your panel. There is a cardboard template in the MMI's shipping box for this purpose.

If you want the MMI to be dust proof and watertight, you must place the black rubber gasket between the thin part of the MMI and your panel. Assemble the two halves using the eight small screws provided.

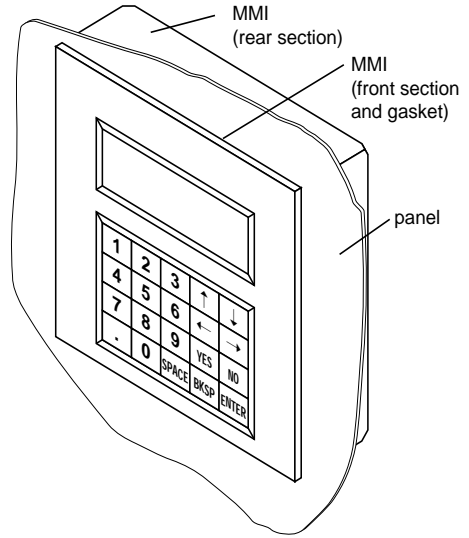

## Surface Mounting

An easier way to mount the MMI is to bolt the two halves together ahead of time, using the eight small screws. If you want the MMI to be dust proof and watertight, put the black rubber gasket between the two halves before screwing them together.

Then cut a hole in your panel for the cable that runs between the MMI and the Si3540. The hole must be at least 5/8" in diameter for the connector to fit through. You will also need two holes that line up with the big mounting holes in the MMI. The mechanical outline on page 19 shows the location of the big mounting holes.

When you mount the MMI to your panel, you will need to use some kind of sealant to keep dust and liquid out. Silicone or latex caulking is okay, or you can make your own gasket from a sheet of compliant material like rubber or RTV.

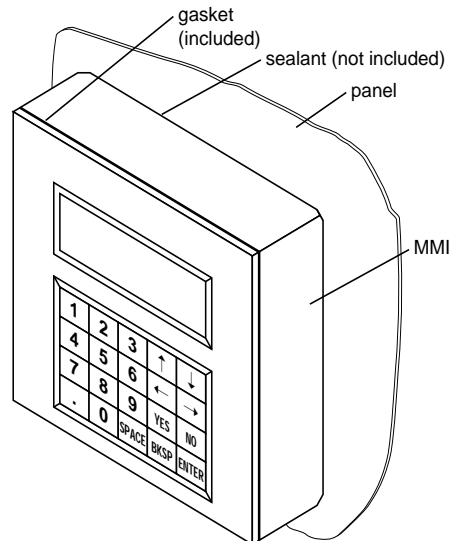

## Recommended Motors

Motor Number	Size inches	Winding Connection	Max Torque oz-in	Current Amps
5014-842	1.38 x 1.38 x 1.57	4 lead	19	1.0
HT17-068	1.65 x 1.65 x 1.30	parallel	23	1.0
HT17-071	1.65 x 1.65 x 1.54	parallel	30	1.25
HT17-075	1.65 x 1.65 x 1.85	parallel	40	1.7
5023-122	2.22 x 2.22 x 2.0	parallel	60	2.0
5023-123	2.22 x 2.22 x 3.0	parallel	100	2.5
5023-124	2.22 x 2.22 x 4.0	parallel	150	3.5
HT23-394	2.22 x 2.22 x 1.54	parallel	60	2.8
HT23-397	2.22 x 2.22 x 2.13	parallel	140	2.8
HT23-400	2.22 x 2.22 x 2.99	parallel	180	2.0
5034-348	3.38 x 3.38 x 2.50	parallel	130	3.5

## Mechanical Outline

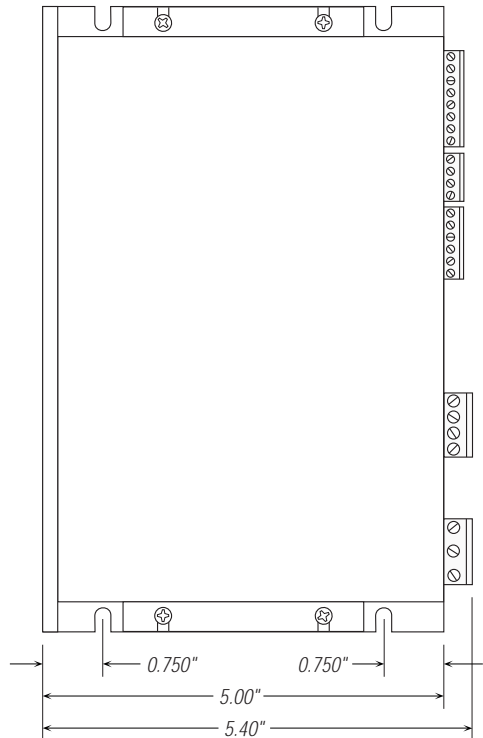
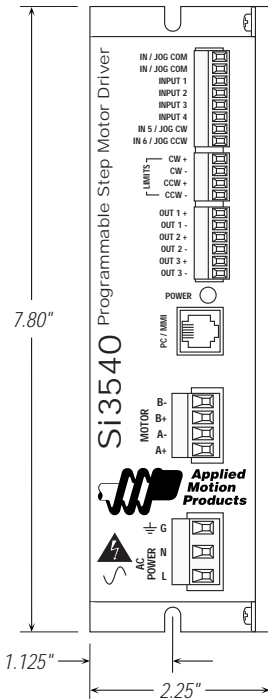

## *Technical Specifications*

<b>Amplifiers</b>	Dual, MOSFET H-bridge, 3 state, pulse width modulated (PWM) switching at 20 kHz. 0.2 - 3.5 amps/phase output current, software selectable. 122 watts maximum output power. Automatic idle current reduction (software programmable) reduces current to motor when idle. Minimum motor inductance is 0.8 mH.
<b>Power Supply</b>	Linear, toroidal transformer based for high reliability and low noise. 100-120 or 200-240 VAC input, switch selectable. 50/60 Hz. DC voltage at nominal line voltage: 35 VDC full load, 40 VDC no load.
<b>Inputs</b>	5 - 24 VDC, optically isolated. 2200 ohms internal resistance. Can be configured for sinking (NPN) or sourcing (PNP) signals.
<b>Outputs</b>	Optically isolated. 12-24 VDC, 100 mA max.
<b>Microstepping</b>	13 software selectable resolutions. Steps per revolution with 1.8° motor: 2000, 5000, 10000, 12800, 18000, 20000, 21600, 25000, 25400, 25600, 36000, 50000, 50800. Waveform: pure sine.
<b>Motion Update</b>	12800 Hz.
<b>Physical</b>	Constructed with black anodized aluminum heat sink and heavy gauge steel housing. 2.25 x 5.40 x 7.80 inches overall. 4.0 lbs. 0 to 50°C ambient operating temperature. See page 17 for detailed drawing.
<b>Connectors</b>	European style, pluggable screw terminal blocks. Motor: 4 position (A+, A-, B+, B-). Signal Input/Output: 18 position (8 input, 6 output, 4 limit). AC input: 3 position (L, N, G).
<b>Agency Approvals</b>	CE (complies with EN55011A, EN50082-1(1997), EN50178(1997)) and TUV.
<b>Fuses</b>	Wickman TR-5 style. Order from Digikey (1-800-DIGIKEY). 110V: P/N WK4250BK-ND (T 1.25 A IEC) 220V: P/N WK4243BK-ND (T 0.63 A IEC).

# Mechanical Outline - Optional MMI

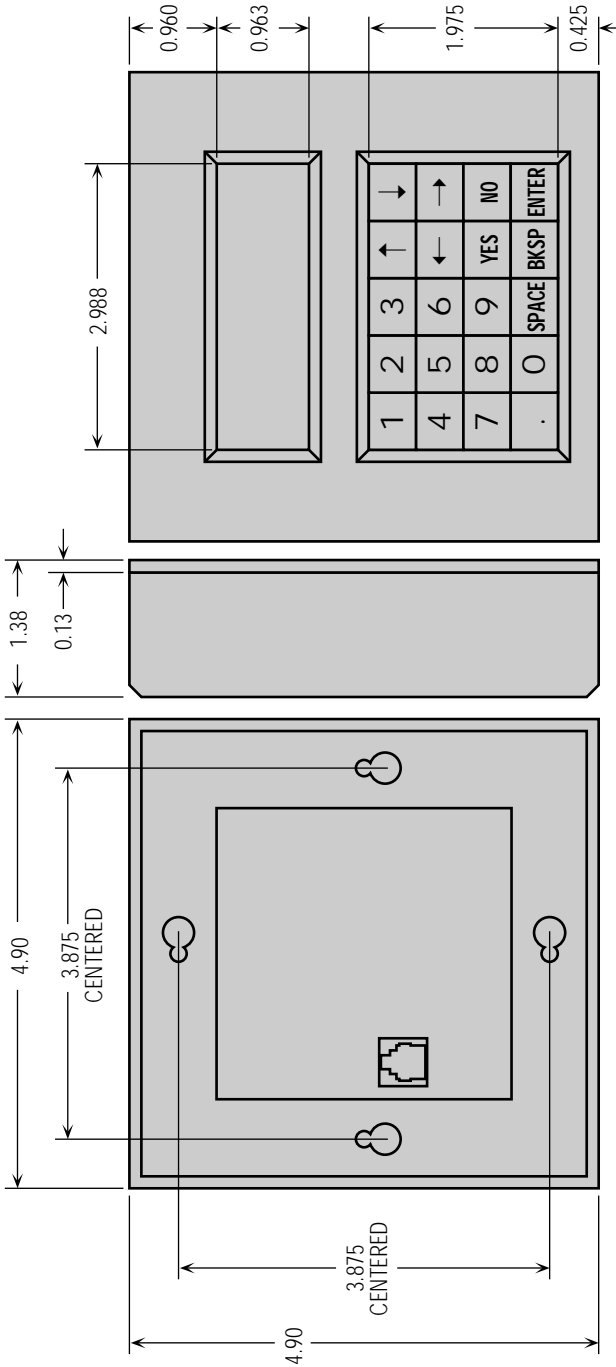

*Applied Motion Products, Inc.*

404 Westridge Drive Watsonville, CA 95076

Tel (831) 761-6555 (800) 525-1609 Fax (831)-761-6544

<http://www.applied-motion.com>

Copyright 1999