

User's Manual

Si5580

Programmable Step Motor Driver

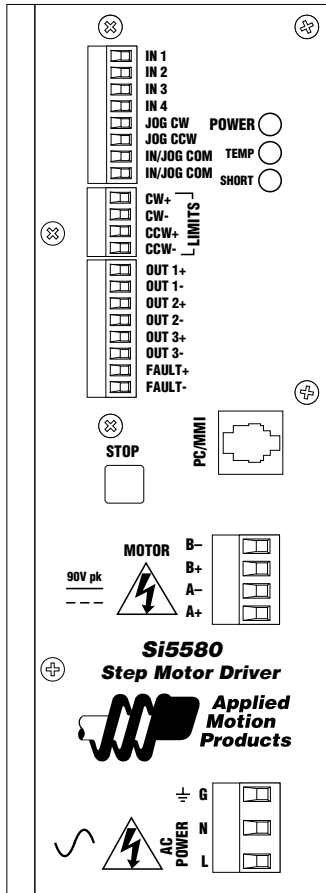

Contents	
Introduction	3
Features	3
Getting Started	4
Connecting the AC Line	5
Installing an AC Line Cord	7
Connecting the Motor	8
Connecting to the PC	10
Jogging	11
Limit Switches	11
Wiring a Mechanical Limit Switch	12
Wiring a Limit Sensor	12
Wiring Inputs	13
Wiring Outputs	15
Faults and Alarms	16
Using the Fault Output	16
Alarm Codes	17
Microstepping	17
Mounting the Drive	18
Mounting the Optional MMI	18
Mechanical Outline	20
Mechanical Outline - Optional MMI	21
Technical Specifications	22
Recommended Motors	23
Block Diagram	23

Introduction

Thank you for selecting an Applied Motion Products motor control. We hope our dedication to performance, quality and economy will make your motion control project successful. If there's anything we can do to improve our products or help you use them better, please call or fax. We'd like to hear from you. Our phone number is (800) 525-1609 or you can reach us by fax at (831) 761-6544.

Features

- Powerful, precise and efficient MOSFET driver providing up to 5.5 amps per phase and microstepping to 50,800 steps per revolution.
- Reliable, efficient, low noise 80 VDC linear, toroidal power supply.
- Powerful, flexible, easy to use indexer.
- Connects by a simple cable to your PC for programming (cable included).
- Microsoft Windows™-based software for easy set up and programming.
- Eight inputs for interacting with the user and other equipment.
- Three outputs for coordinating external equipment.
- Accepts 110 or 220 volts AC power (factory preset for 110 volts).
- Sturdy 3 x 8 x 5.3 inch metal case with integral heat sink.

Mounting brackets included.

- I/O is optically isolated, 5-24 V, sinking or sourcing signals. PC/MMI port is RS-232.
- Pluggable screw terminal connectors for I/O, motor and AC power (all mating connectors included).
- Three LEDs indicate power, drive and indexer status.
- Overcurrent (short circuit) and over temperature protection.
- Optional man machine interface (MMI) allows operator to enter distances, speeds, cycle counts and more.
- CE and TUV compliant

Getting Started

To use your Si5580 motor control, you will need the following:

- a power cable (line cord)
- a compatible step motor
- a small flat blade screwdriver for tightening the connectors - an Applied Motion Products screwdriver suitable for this purpose is included with your drive.
- a personal computer running Windows 3.2, 95, 98, NT, W2K, XP, Vista or Vista64, with a 9 pin serial port (486 or better with 8 MB RAM recommended)
- the Si Programmer™ software that came with your Si5580
- the programming cable and adapter that came with your Si5580
- Si Programmer™ software manual

The sketch below shows where to find the important connection and adjustment points. Please examine it now.

All mating connectors are included.

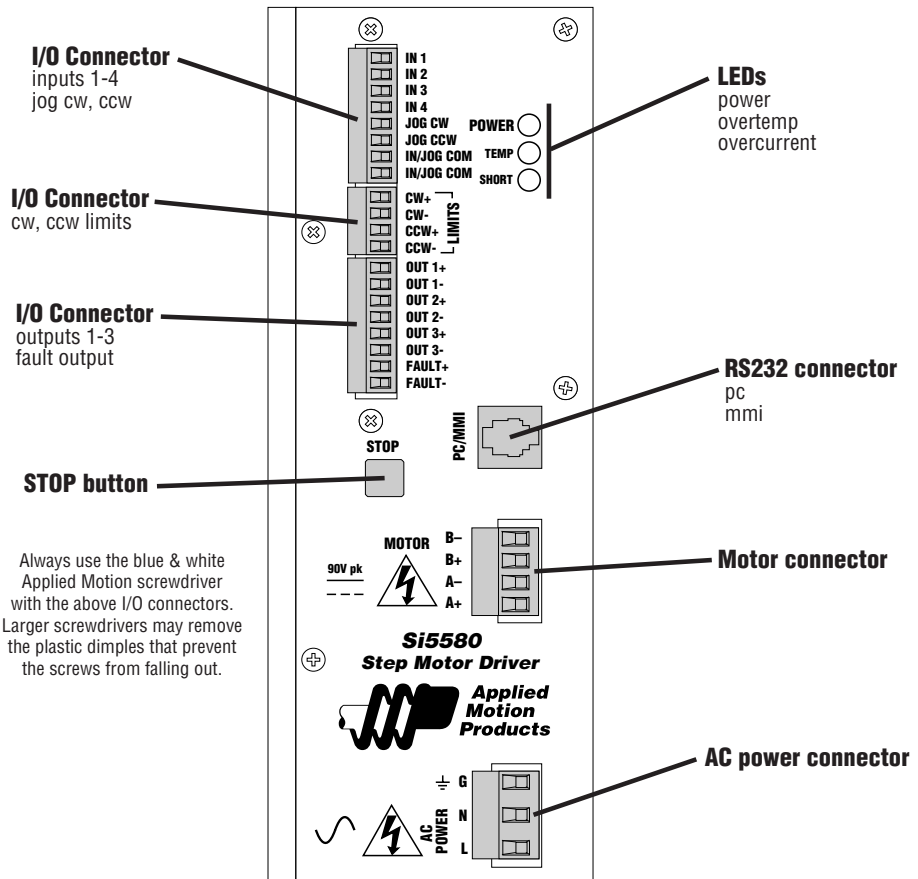

Connecting the AC Line

The Si5580 is set for 110 VAC operation at the factory. If you use **110 VAC** power, all you need to do is install a power cord and plug it in (skip to **Installing an AC Line Cord**). If you plan to use **220 VAC** power, follow the instructions below.

Note: If you plan to hard wire the Si5580 to AC power, consult a qualified electrician and observe all building and electrical codes. AC power can be dangerous.

220 VAC Instructions

In order to use 220 volts, you'll need to set the 110/220 VAC switch to the correct position and install the correct fuse.

- 1) Remove all mating connectors from the drive.
- 2) Set the drive on its side, with the aluminum heat sink fins up.
- 3) With a medium-sized phillips screwdriver, remove the eight screws at the perimeter of the case and the three screws that connect the heat sink to the internal heat bar, keeping track of which screws go where. See the diagram below.

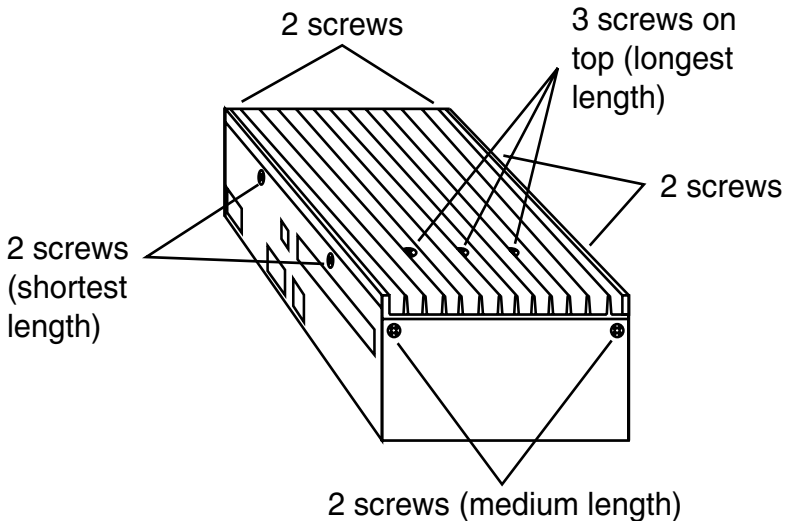

Note: Do not remove the 1/4-20 Allen head screw that connects the heat sink to the internal transformer.

- 4) Separate the heat sink assembly from the cover and note how the wires are routed to the PC board. There are labels on the PC board to assist you.
- 5) Disconnect the two sets of wires connecting the heat sink/transformer assembly to the chassis/PC board. The 110/220 VAC SWITCH is located on the PC board, near the AC power connector. See diagram on page 6.

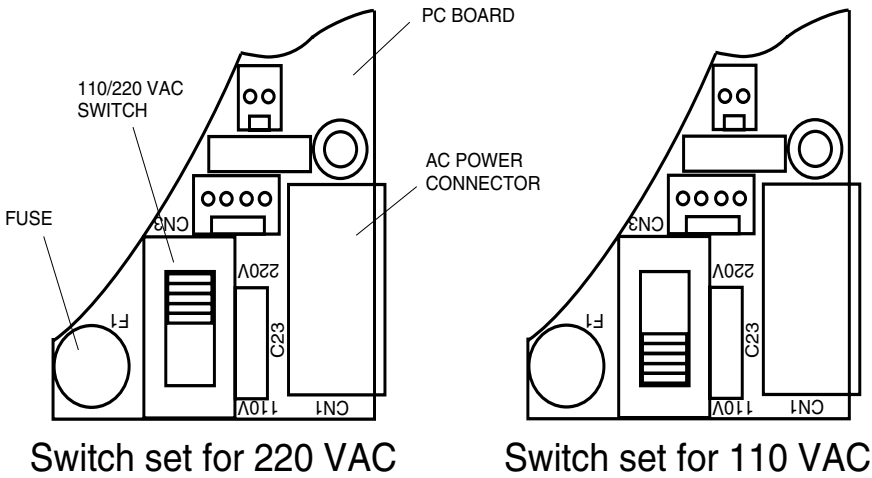

- 6)** Remove the 110 VAC fuse and install the 220 VAC fuse that came with your drive. There is a label inside the drive that gives the correct fuse values.
- 7)** Place the voltage selector switch in the correct position according to the labels on the printed circuit board near the switch. See the diagram above.
- 8)** Re-assemble the chassis/PC board assembly to the heat sink/transformer assembly by following steps 4 & 5 in reverse. Again, pay close attention to the correct orientation of the two sets of wires connecting these assemblies.
- 9)** Install and tighten the screws removed in step 3. Use the correct length screw according to the hole location.

You are done converting your drive to 220 VAC operation and are now ready to install the AC line cord.

Installing an AC Line Cord

Remove about 5 mm (3/16 inches) of insulation from each of the three wires of your line cord. (That's right, three wires. For safety, always use a three wire power cord on anything with a metal case.)

Depending on where you got your power cord, it may have black, white and green wires or brown/blue/green.

The AC power plug that was shipped with your Si5580 might be one of two types. The "old style" is shown in the diagram below, on the left. The "new style", shown on the right, comes with an insulating rubber boot.

Make sure you follow the proper sketch for your connector style.

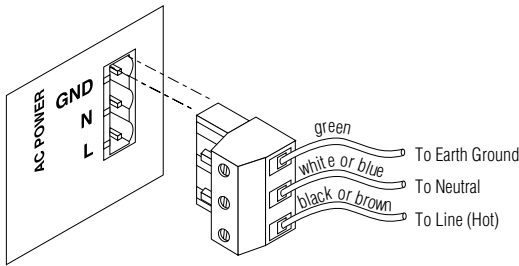

**"Old Style"
AC Power Plug**

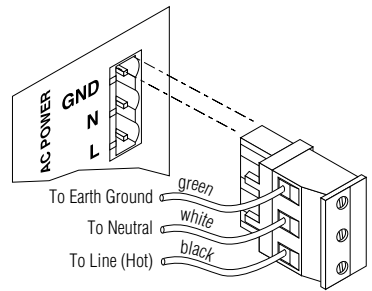

**"New Style"
AC Power Plug**



Always unplug the line cord from the wall before attaching it to the Si5580

- Connect the black or brown wire to the Si5580 "L" terminal of the AC power connector. That is the line, or "hot" connection.
- Connect the white or blue wire to neutral. That's the "N" terminal.
- Finally, and most importantly, connect the green wire to the GND terminal. That connects the Si5580 metal enclosure and DC power supply ground to earth ground.

Connecting the Motor



- Never connect the motor to the driver when the AC power is on.**
- Secure any unused motor leads.**
- Never disconnect the motor while the AC power is on.**
- Never connect motor leads to ground or to a power supply.**

You must now decide how to connect your motor to the drive.

Four lead motors can only be connected one way. Please follow the sketch at the right.

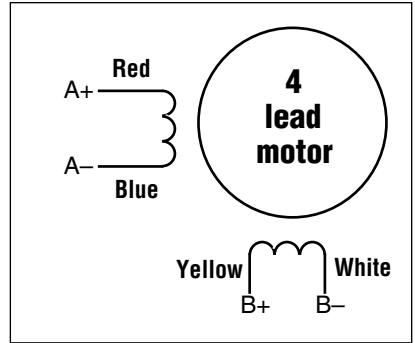

4 Leads

Six lead motors can be connected in series or center tap. In series mode, motors produce more torque at low speeds, but cannot run as fast as in the center tap configuration. In series operation, the motor should be operated at 30% less than the rated current to prevent overheating. Wiring diagrams for both connection methods are shown below.

Note: NC means not connected to anything.

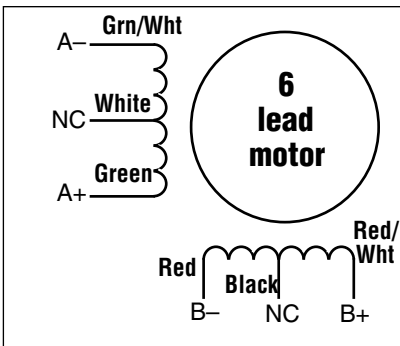

6 Leads Series Connected

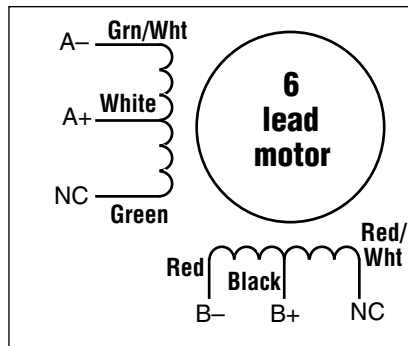

6 Leads Center Tap Connected

Eight lead motors can also be connected in two ways: series and parallel. As with six lead motors, series operation gives you more torque at low speeds and less torque at high speeds. In series operation, the motor should be operated at 30% less than the rated current to prevent overheating. The wiring diagrams for eight lead motors are shown below.

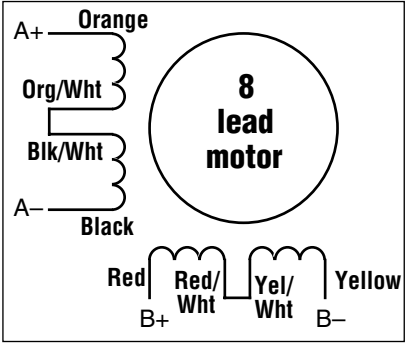

8 Leads Series Connected

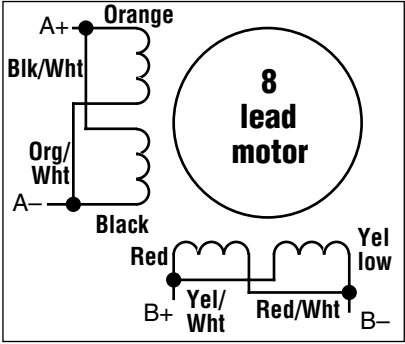

8 Leads Parallel Connected

Connecting to the PC

- Locate your computer within 6 feet of the Si5580.
- Your Si5580 was shipped with a black adapter plug. It has a telephone style jack at one end and a larger 9 pin connector at the other. Plug the large end into the COM1 serial port of your PC. Secure the adapter with the screws on the sides. If the COM1 port on your PC is already used by something else, you may use the COM2 port for the Si5580. On some PCs, COM2 will have a 25 pin connector that does not fit the black adapter plug. If this is the case, and you must use COM2, you may have to purchase a 25 to 9 pin serial adapter at your local computer store.
- Your Si5580 was also shipped with a 7 foot telephone line cord. Plug one end into the adapter we just attached to your PC, and the other end into the PC/MMI jack on your Si5580.



Never connect the Si5580 to a telephone circuit. It uses the same connectors and cords as telephones and modems, but the voltages are not compatible.

Programming Note: Always apply power to the Si5580 after the Si Programmer™ software is running on your PC.

Jogging

Two of the Si5580 input terminals are provided for jogging the motor. The inputs are labeled “JOG CW” and “JOG CCW”. Activating one of the inputs commands the drive to move the motor at a pre-designated speed until the contact is opened. A relay or mechanical switch can be used to activate the jog inputs. 5-24 volt circuitry can be used. The schematic diagram of the input circuit is shown below.

If you're using a switch or relay, wire one end to the JOG input and the other to the power supply negative (-) terminal. Then connect the COM input to the power supply positive (+) terminals.

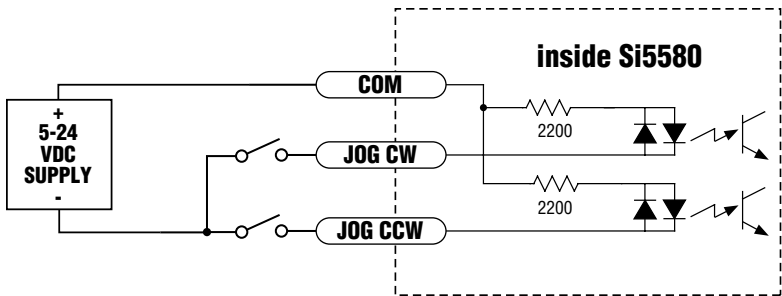

Limit Switches

The Si5580 has two limit switch inputs, LIMIT CW and LIMIT CCW. By connecting these inputs to switches or sensors that are triggered by the motion of the motor or load, you can force the Si5580 to operate within certain limits. This is useful if a program error could cause damage to your system from the motor traveling too far.

As the limit inputs of the Si5580 are optically isolated, you can choose a voltage between 5-24 Vdc to apply to your limit circuitry. This allows you to have long wires on limit sensors with less risk of introducing noise to the Si5580 (choose 12-24 Vdc for best noise immunity). The power light will blink if a limit switch is activated. The schematic diagram of the limit switch input circuit is shown below.

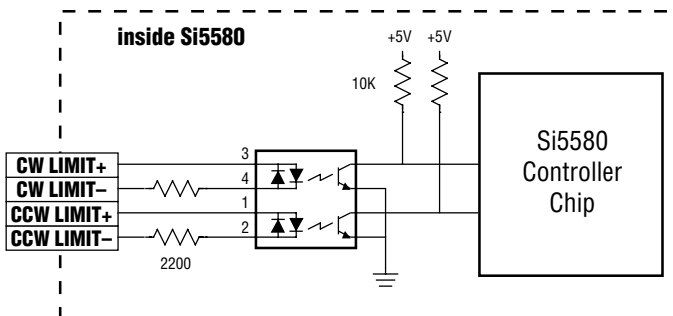

Wiring a Mechanical Limit Switch

You can use normally open or normally closed limit switches. Either way, wire them as shown here.

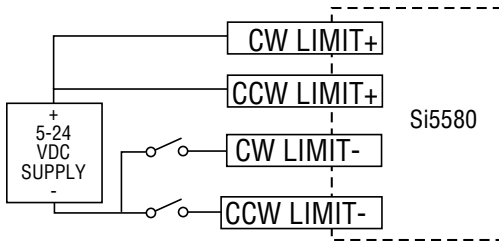

Wiring a Limit Sensor

Some systems use active limit sensors that produce a voltage output rather than a switch or relay closure. These devices must be wired differently than switches.

If your sensor has an open collector output or a **sinking** output, wire it like this:

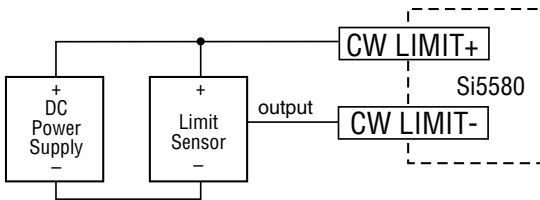

Wiring for Sinking or Open Collector Output

If the sensor output goes low at the limit, select the option "closed". If the output is open, or high voltage, choose "open".

Other sensors have **sourcing** outputs. That means that current can flow out of the sensor output, but not into it. In that case, wire the sensor this way:

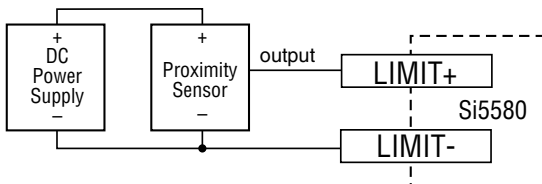

Wiring for Sourcing Output

If the sensor output goes high at the limit, choose the program option "closed". If the output is low at the limit, select "open".

Wiring Inputs

The Si5580 input circuits can be used with sourcing or sinking signals, 5 to 24 volts. This allows connection to TTL circuits, PLCs, relays and mechanical switches. Because the input circuits are isolated, they require a source of power. If you are connecting to a TTL circuit or to a PLC, you should be able to get power from the PLC or TTL power supply. If you are using relays or mechanical switches, you will need a 5-24 power supply. This also applies if you are connecting the Si5580 inputs to another Si product from Applied Motion, like the Si-1 and Si-100 indexers, or the Si3540 and 7080i indexer-drives.

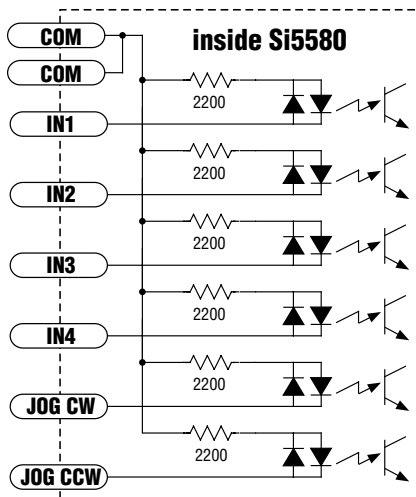

Note: If current is flowing into or out of an Si5580 input, the logic state of that input is low. If no current is flowing, or the input is not connected, the logic state is high.

The diagrams on the following pages show how to connect Si5580 inputs to various devices.



The maximum voltage that can be applied to an input terminal is 24 volts DC. Never apply AC voltage to an input terminal. Maximum current is 20 mA per input.

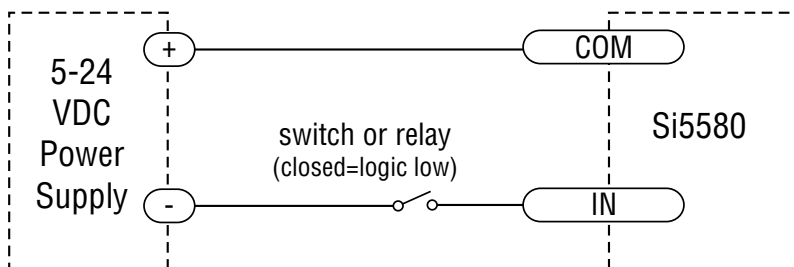

Connecting an Input to a Switch or Relay

Use normally open momentary switch to trigger Si5580 using Wait Input instruction.

Use single throw switch for parameter selection using If Input instruction.

Use normally open momentary switch for jogging.

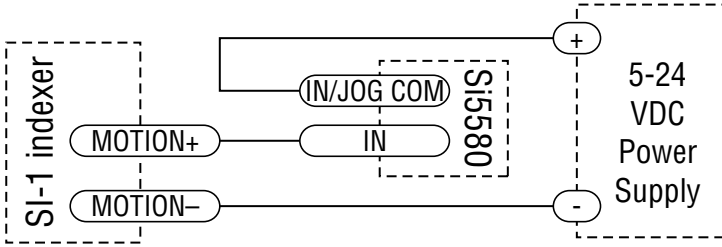

Connecting an Input to the Si-1 Motion Output

(Set Si-1 motion signal to “in position”. Si-1 will trigger Si5580 at end of each move).

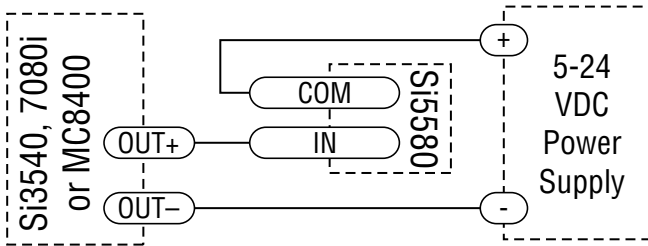

Connecting a 3540i, Si3540, 7080i or MC8400

(When output closes, Si5580 input goes low).

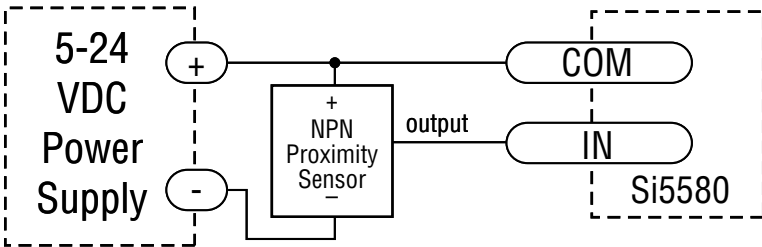

Connecting an NPN Type Proximity Sensor to an Si5580 input

(When prox sensor activates, Si5580 input goes low).

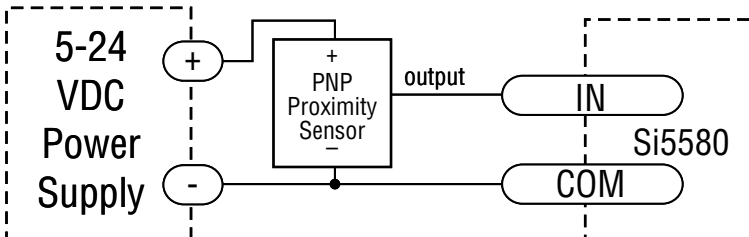

Connecting a PNP Type Proximity Sensor to an Si5580 input

(When prox sensor activates, Si5580 input goes low).

Wiring Outputs

Before we discuss the output conditions, we need to talk about the circuitry. All three Si5580 outputs are optically isolated. That means that there is no electrical connection between the indexer-drive and the output terminals. The signal is transmitted to the output as light. What you “see” is a transistor (NPN type) that closes, or conducts current, when the output is “low”. When the output is high, the transistor is open.

Note: At power-up, the Si5580 sets all three programmable outputs high (open circuit).



The maximum voltage between any pair of + and - output terminals is 24 volts DC. Never connect AC voltages to the Si5580 output terminals. Maximum current is 100 mA per output.

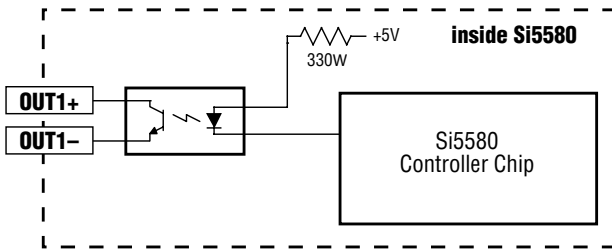

Schematic Diagram of Si5580 Output Circuit

Since there is no electrical connection to the Si5580, you must provide the source of current and voltage, typically from a power supply. You must also limit the current to less than 100 mA so that the output transistor is not damaged. You would normally use a resistor for this, but some loads (such as PLC inputs) limit the current automatically.

The diagram below shows how to connect an Si5580 output to an optically isolated PLC input.

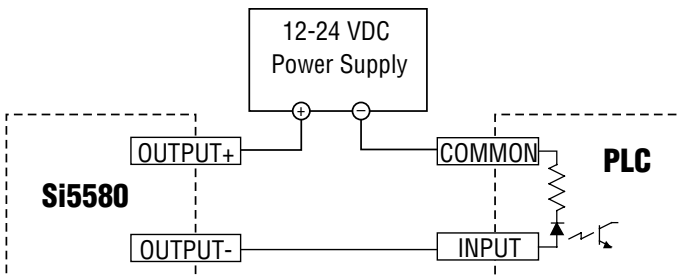

Faults and Alarms

The Si5580 provides protection against motor short circuits and excessive drive temperature. The drive also provides an alarm if a limit switch is reached.

If the TEMP light is on the Si5580 has detected a thermal problem and shut down the amplifiers. The first thing you should do is to unplug the drive from the power source. If the heat sink is very hot, the drive has probably overheated - please use caution, do not directly touch heat sink to avoid a possible burn. Usually this means you need more air flow around the drive.

If the SHORT light is on the Si5580 has detected a short circuit and has shut down the amplifiers. Unplug the drive from the power source. Check the motor wiring carefully. Make sure that the connections to the drive are secure and that any unused motor leads are insulated from the drive and power supply and from each other. Check the motor leads for shorts between phases or to ground.

If the power light is blinking, this indicates an alarm condition caused by the activation of a limit switch.

Using the Fault Output

The Si5580 has a fault output to tell you if the drive has overheated or if a short circuit has occurred at the motor outputs. The fault output is optically isolated for noise immunity. This makes it more flexible and more reliable, but also harder to hook up. To connect to a typical PLC, follow the sketch below. For other connections, consult the factory.

The photo transistor turns on when there is a fault. In the circuit below, the signal will be open when there is no fault. The signal will go low (0 volts) if a fault occurs.

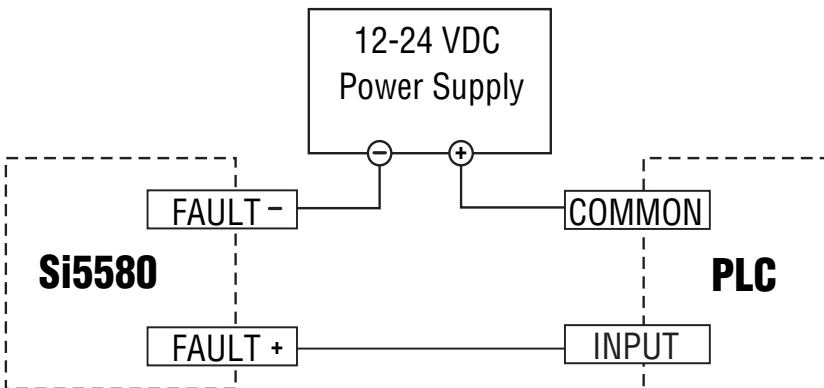

Alarm Codes

In the event of an error, the red and green LEDs will flash in alternating red-green patterns as shown below. The pattern repeats until the alarm is cleared.

CODE:	ERROR:
2 red, 1 green	CCW Limit
2 red, 2 green	CW Limit
1 red, 3 green	subroutine stack overflow
2 red, 3 green	subroutine stack underflow
4 red, 3 green	bad instruction in Si program (memory or software)
7 red, 1 green	serial communication error

Microstepping

Most step motor drives offer a choice between full step and half step resolutions. In full step mode, both motor phases are used all the time. Half stepping divides each step into two smaller steps by alternating between both phases on and one phase on.

Microstepping drives like the Si5580 precisely control the amount of current in each phase at each step position as a means of electronically subdividing the steps even further. The Si5580 offers a choice of 13 step resolutions. The highest setting divides each full step into 254 microsteps, providing 50,800 steps per revolution when using a 1.8° motor.

In addition to providing precise positioning and smooth motion, microstep drives can be used for motion conversion between different units. The 25,400 step/rev setting is provided as a means of converting motion from metric to english (there are 25.4 mm in an inch). Other settings provide step angles that are decimal degrees (36,000 steps/rev makes the motor take 0.01° steps). Some settings are used with lead screws. When the drive is set to 2000 steps/rev and used with a 0.2 pitch lead screw, you get 0.0001 inches/step.

The microstep resolution of the Si5580 is set by the Si Programmer™ software.

Mounting the Drive

You can mount your drive on the wide or the narrow side of the case. Either way you'll need to get the brackets and screws out of the accessory bag and bolt them onto the Si5580. If you're mounting on the narrow side, you'll first have to remove one of the screws from the heat sink, then put it back with the bracket in place, as shown in the figure.

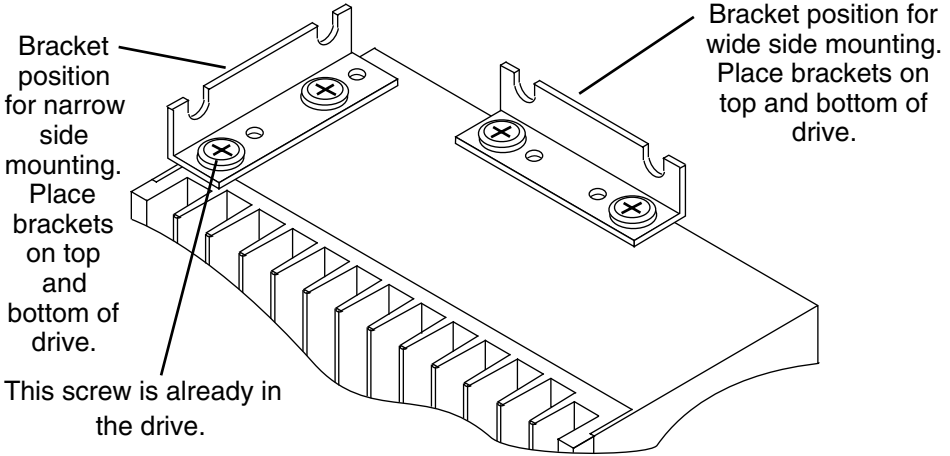

***Never use your drive in a space where there is no air flow or where the ambient temperature exceeds 50°C (120°F).
Never block the fins of the heat sink or the vent holes.
Never put the drive where it can get wet.
Never allow metal particles near the drive.***

Mounting the Optional MMI

There are two ways to mount the MMI in your application. No matter which method you choose, you'll need to connect the MMI to your Si5580 with the programming cable. You will not, however, need the adapter plug. The MMI has the same telephone style connector as the Si5580.

Depending on how you mount the MMI and cable in your application, you may find that it is difficult to remove the cable from the back of the MMI. If this is the case, and you need to reprogram the Si5580, you can use any telephone line cord as a programming cable. They are available at most supermarkets and discount stores. Please be careful not to lose the adapter plug that connects the telephone cord to the COM port of your PC. The adapter is a custom made part and is only available from Applied Motion.

Flush Mounting

When you remove the MMI from the shipping carton, you will notice that it has two parts. The first is a fairly thin section that contains the keypad, display and some circuit boards. The other part is thicker and contains the telephone jack and a cable that connects to the keypad assembly.

When you flush mount the MMI in a panel, only the thin section will stick out from your panel - the large portion mounts behind your panel. You'll need to cut a precise section from your panel. There is a cardboard template in the MMI's shipping box for this purpose.

If you want the MMI to be dust proof and watertight, you must place the black rubber gasket between the thin part of the MMI and your panel. Assemble the two halves using the eight small screws provided.

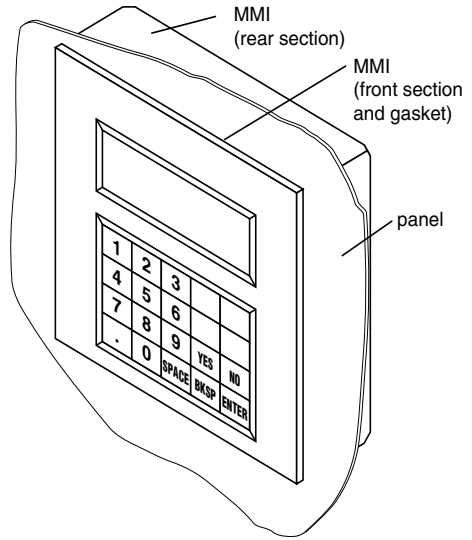

Surface Mounting

An easier way to mount the MMI is to bolt the two halves together ahead of time, using the eight small screws. If you want the MMI to be dust proof and watertight, put the black rubber gasket between the two halves before screwing them together.

Then cut a hole in your panel for the cable that runs between the MMI and the Si5580. The hole must be at least 5/8" in diameter for the connector to fit through. You will also need two holes that line up with the big mounting holes in the MMI. The mechanical outline on page 21 shows the location of the big mounting holes.

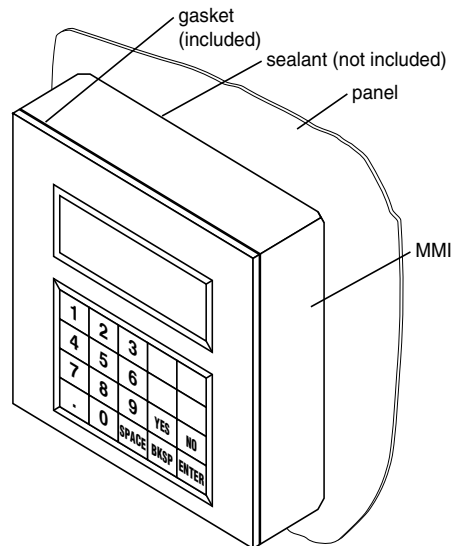

Mechanical Outline - Optional MMI

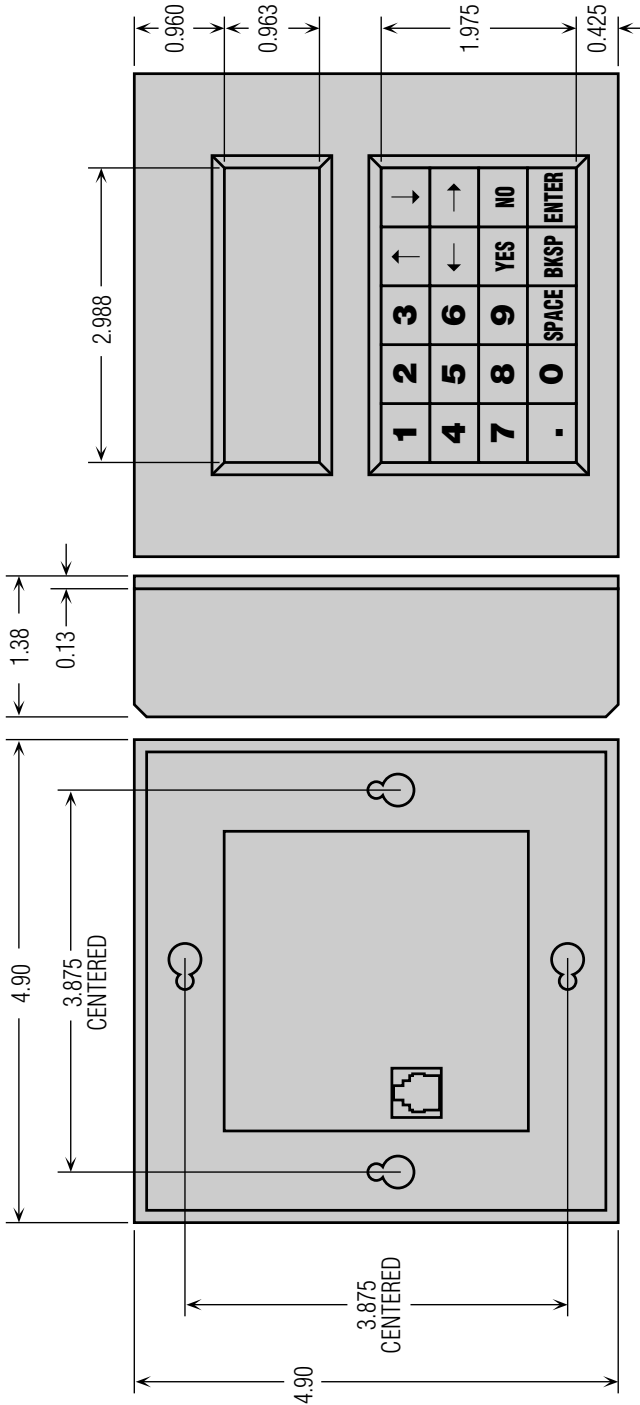

Technical Specifications

Amplifiers

Dual, MOSFET H-bridge, 3 state, pulse width modulated switching at 20 kHz. 0.5 - 5.5 amps/phase output current, switch selectable in 0.2 increments. 340 watts maximum output power. Overcurrent and overtemperature protection. Automatic idle current reduction (defeatable), reduces current to 50% of setting after one second. Minimum motor inductance is 0.8 mH.

Power Supply

Linear, toroidal transformer based for high reliability and low noise. 110 or 220 VAC input, switch selectable. 50-60 Hz. 340 W max. DC voltage at nominal line voltage: 75 VDC full load, 90 VDC no load.

Inputs

Optically isolated. 5-24 VDC, 20 mA max. 2200 Ω internal resistance. Can be configured for sinking (NPN) or sourcing (PNP) signals.

Outputs

Optically isolated. 12-24 VDC, 100 mA max.

Microstepping

13 switch selectable resolutions: 2000, 5000, 10000, 12800, 18000, 20000, 21600, 25000, 25400, 25600, 36000, 50000, 50800 steps/rev. Waveform: pure sine.

Motion Update

12800 Hz.

Physical

Constructed with black anodized aluminum heat sink and heavy gauge steel housing. 3 x 5.3 x 8 inches overall. 7.8 lbs. Ambient temperature range: 0-70 deg C. Power, over temp, and motor short circuit LEDs. Mounting brackets and switch cover included. See page 20 for detailed drawing.

Connectors

European style, pluggable screw terminal blocks. Motor: 4 position (A+, A-, B+, B-). Signal Input/Output: 18 position (8 input, 6 output, 4 limit). AC input: 3 position (L,N,G).

Agency Approvals

CE: complies with EN55011A, EN50082-1(1996), EN50178(1997);TUV.

Fuses

Wickman TR-5 style.

110V: P/N 3721250041 (2.5 A IEC, slow)

220V: P/N 3721125041 (1.25 A IEC, slow)

P/N 3741630041 (6.3 A UL, slow)

Recommended Motors

The following tables lists motors and current settings that are recommended for the Si5580 drive.

Motor Number	Winding Connection	Max Torque oz-in	Max Power Watts	Current Setting Amps/phase
5023-122	parallel	75	60	2.0
5023-123	parallel	120	93	2.5
5023-124	parallel	177	110	3.5
5034-348	parallel	185	133	4.8
5034-349	parallel	300	151	5.0
5034-350	parallel	390	213	5.5
5042-022	parallel	595	300	5.5

Block Diagram

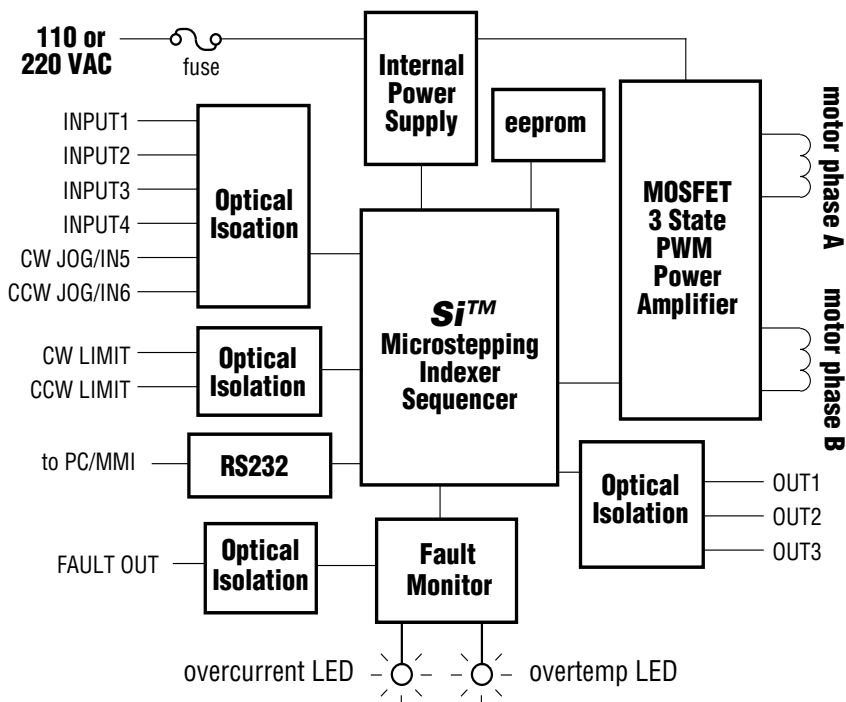

Applied Motion Products, Inc.

404 Westridge Drive Watsonville, CA 95076

Tel (831) 761-6555 (800) 525-1609 Fax (831) 761-6544

Copyright 1999