

Mechanical Outline

9/3/99

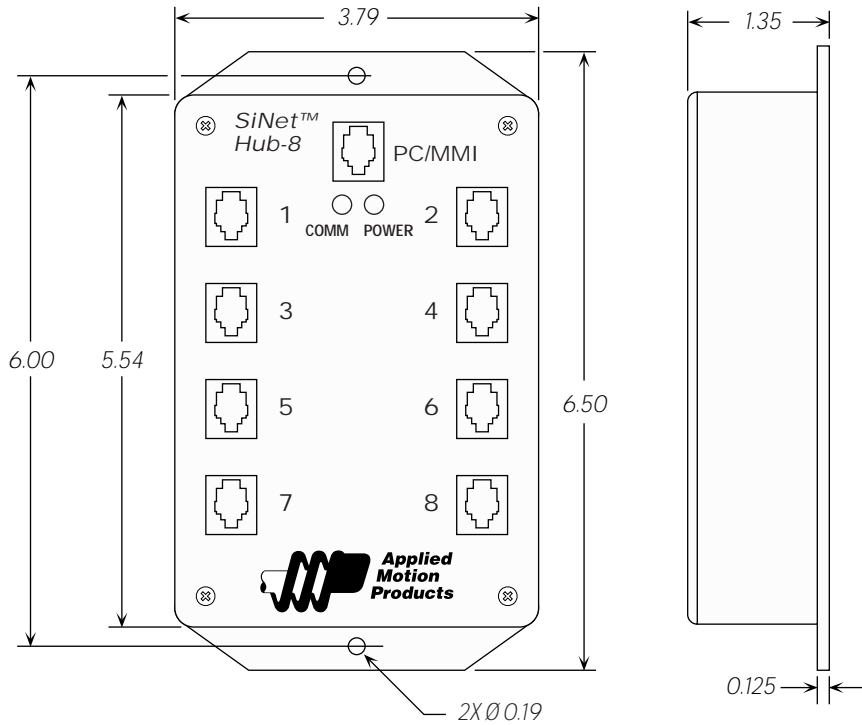

Hardware Manual

SiNet™ Hub 8

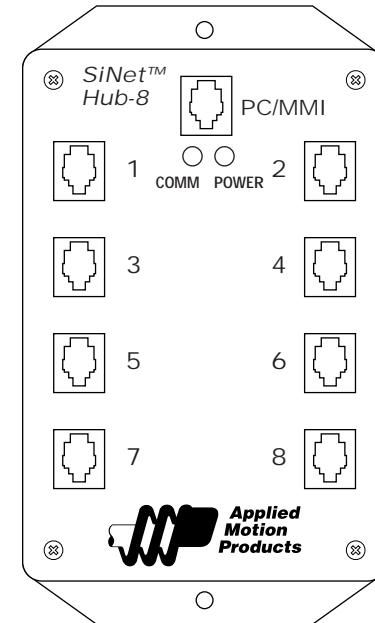

Note:
Stored Program
Mode and the
SiNet
Programmer™
software will be
introduced in
late 1999.

Applied Motion Products, Inc.
404 Westridge Drive, Watsonville, CA 95076
Tel (831) 761-6555 (800) 525-1609 Fax (831) 761-6544

Applied Motion Products
motors • drives • controls

Introduction

Thank you for selecting an Applied Motion Products motion controller. We hope our dedication to performance, quality and economy will make your motion control project successful. If there's anything we can do to improve our products or help you use them better, please call or fax. We'd like to hear from you. Our phone number is (800) 525-1609 or you can reach us by fax at (831) 761-6544.

Features

- Includes easy to use Windows set up and programming software
- In Router Mode, allows PC to control up to 8 motion control axes from one serial port, using SiNet Command Language (SCL).
- In Stored Program Mode, the hub is programmed with your PC and our easy to use *SiNet Programmer™* software, then runs stand alone, making the PC port available for a Man Machine Interface (MMI).
- Serial interface cable included.
- Works with any combination of Applied Motion Si™ indexer-drives: Si3540, Si5580, Si4500, 3540i or 7080i.
- Also can be used with the Si-100 indexer, which provides step and direction signals compatible with a wide range of step motor and servo motor drives.
- Uses modular telephone line cords for all connections for low cost, reliable and easy wiring.
- No power supply required. The Hub 8 is powered by the drive connected to port 1.
- The address of each drive is set automatically by connecting it to a port, making installation and field service fast and simple.
- Built-in mounting flanges make installation easy.
- Front panel LEDs tell you if the hub has power, and whether it is receiving commands from the PC.

Compatible Indexers & Indexer-Drives

All units have 8 programmable inputs and 3 programmable outputs

Si4500: runs on 120VAC, 170V bus, 4.5A/phase, 2000 - 50800 steps/rev

Si5580: runs on 120/240VAC, 80V bus, 5.5A/phase, 2000 - 50800 steps/rev

Si3540: runs on 120/240VAC, 40V bus, 3.5A/phase, 2000 - 50800 steps/rev

7080i: runs on 24 - 80 VDC, 7A/phase, 2000 - 50800 steps/rev

3540i: runs on 12 - 42 VDC, 3.5A/phase, 2000 - 50800 steps/rev

Si-100: indexer only, runs on 120/240VAC, provides industry standard step and direction signals to a wide range of step motor and servo motor drives

Programming - Stored Program Mode

In this mode, a multi-axis motion control program is stored inside the hub, and the hub operates without the PC. The PC is used to develop and test your program with the aid of our *SiNet Programmer™* software.

Please refer to the *SiNet Programmer™ Software Manual* when installing the software and developing programs.

Technical Specifications

Power Runs on 5 VDC, 90 mA max. Power is provided by Si™ indexer-drive on Port 1. Also provides up to 50 mA for MMI via PC/MMI port.

Communication Ports 1 - 8: RS232, 9600 bps, 8 data bits, one stop bit, no parity. MMI: same.
PC in router mode: same.
PC when running SiNet Programmer software: 19200 bps.
Max cable length, any port: 50 feet.

Physical Molded plastic case. RJ11 connectors. 1.35 x 3.8 x 6.5 inches (34.3 x 96.5 x 165.1 mm). Weighs 9 ounces (250 grams). Two red LEDs. Operating temperature range: 0 - 70° C.

Pin Assignments

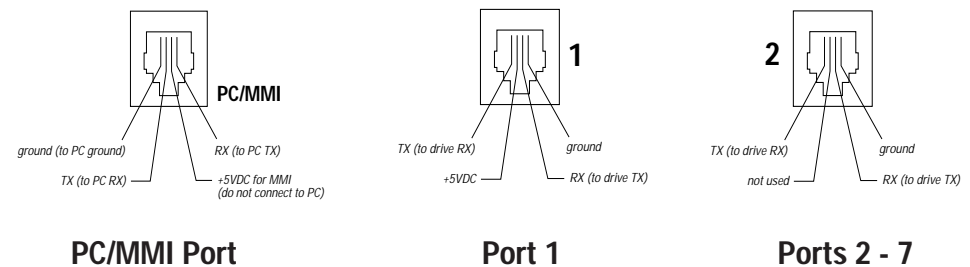

Programming - Router Mode

When operated in router mode, the Hub-8 is a motion control network router. It transfers commands from your PC's serial port to individual Si™ drives (up to 8), and processes responses from the drives.

In router mode, the drives are commanded and queried using SiNet Command Language (SCL).

The *SiNet Command Language* is explained in the latest copy of the *Si Programmer™ Software Manual*, which is shipped with the drives. You can use one of the cables that comes with the drives to connect the Hub-8 to your PC. Ordinary telephone cables are used to connect the hub to the drives. The hub operates at 9600 baud, 8 data bits, one stop bit, no parity. There is no hardware handshaking.

The Hub-8 requires no power supply. It gets the power it needs from drive #1, so **make sure you have a drive connected to port #1**. You can apply power to all the drives at the same time. However, you may want to power up the drives "sequentially" to balance the load on your power circuit. **If you do not power up all the drives together, make sure you apply power to drive #1 first.**

The Hub-8 has two status LEDs marked COMM and POWER. If you have a drive connected to port #1 and that drive has power, then the POWER LED on the Hub-8 should light up.

The COMM LED will flash each time a command is sent from the PC to the Hub-8. You can use our *SiNet™ Setup* software to test the hub-8, and to get familiar with SCL commands. The *SiNet™ Setup* software is shipped with the drives.

The addressing scheme is simple. If you want to send a Feed to Length command to the drive connected to port #1, send the hub the ascii string "1FL" followed by a carriage return (ascii 13). If you omit the address character, the command is "global" and will be sent to all eight drives. That is useful if you want to send the same parameter (accel rate, for example) to all the drives.

If you ask a drive for status information, the hub will append an address character to the drive's response. For example, sending "4RS" to the hub will result in the hub sending the host "4R" (assuming the drive is "ready." If it's moving, you'll see the response "4M".) This is helpful if you send a global status request, since all drives will respond at the same time.

Getting Started

The SiNet™ Hub 8 can be used two different ways. You must choose based on your application.

Stored Program Mode is easy. Just install our *SiNet Programmer™* software on your PC, and point and click your way to a completed program. Once you're done preparing and testing your program, it stays inside the hub and runs without the PC. Your program not only controls up to 8 motion control axes, it can also interact with an operator using our Man Machine Interface (MMI). The MMI lets the operator make decisions, choose operations from a menu, visually position your load, and enter part counts, move distances and speeds.

The *SiNet Programmer™* software not only saves you time because it's easy to learn and easy to use, it also eliminates most of the things that can go wrong during the set up and programming of a system.

We highly recommend that you try the *SiNet Programmer™* software before considering router mode.

To use your SiNet™ Hub 8 in Stored Program Mode, you will need:

- ✓ at least one Si™ indexer or indexer drive, connected to port 1.
- ✓ a step motor for your drive.
- ✓ a Pentium or better PC running Windows 95, 98 or NT with 10MB free disk space and an unused 9 pin serial port. The *SiNet Programmer™* software does not run with Windows 3.1.
- ✓ a PC serial interface cable (it comes with your Si™ indexer/drive)
- ✓ a modular telephone line cord for each indexer/drive (the hub comes with one 7 foot cable, and each drive includes a 7 foot cord. You can get longer cords anywhere telephone cords are sold, such as your local supermarket, discount store or Radio Shack)

Router Mode is for systems where you will be using your own software to control multiple indexer-drives. The Hub 8 routes commands to individual drives based on address characters that your software sends along with the commands. It also routes messages from the drives back to the host PC or PLC. In Router Mode, the indexer-drives are commanded and queried using SiNet Command Language (SCL). *Router Mode is the most versatile way to use the hub, but also the most difficult because*

you'll need a highly skilled programmer to write your host software.

To use your SiNet™ Hub 8 in Router Mode, you will need:

- ✓ at least one Si™ indexer or indexer drive, connected to port 1.
- ✓ a step motor for your drive.
- ✓ a PC running Windows 3.1, 95, 98 or NT with an unused 9 pin serial port.
- ✓ a PC serial interface cable (it comes with your Si™ indexer/drive)
- ✓ a modular telephone line cord for each indexer/drive (the hub comes with one 7 foot cable, and each drive includes a 7 foot cord. You can get longer cords anywhere telephone cords are sold, such as your local supermarket, discount store or Radio Shack)
- ✓ your own custom software to command and query the indexer/drives using *SiNet Command Language*. This means you need a highly skilled computer programmer working with a language system like C, Visual Basic or Labview.

The sketch below identifies some of the physical features of the SiNet™ Hub 8. Please examine it now.

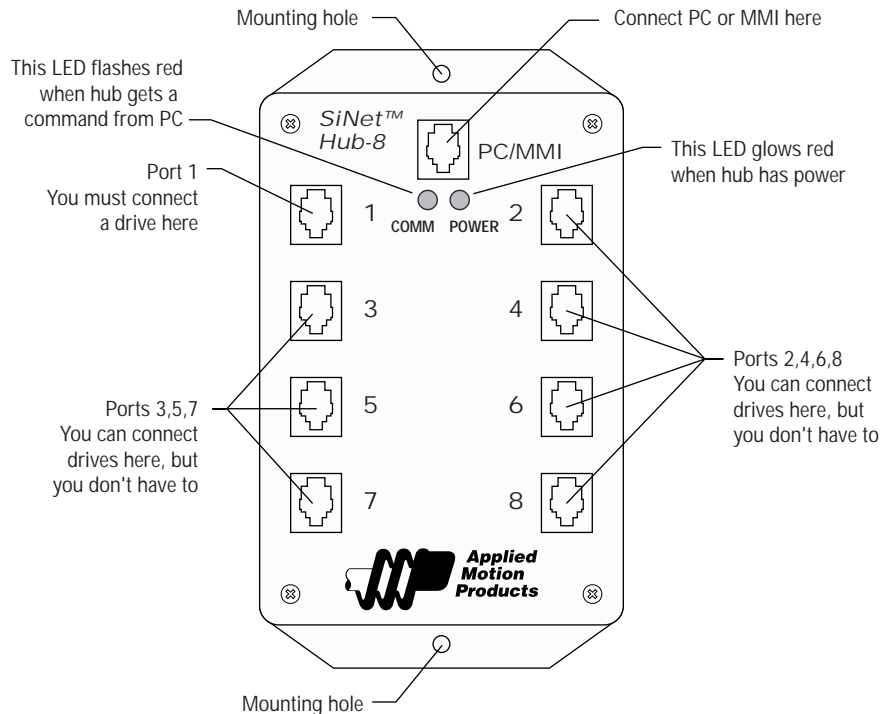

Connecting the Hub

All connections are made using four wire cables with RJ11 connectors, the same cords used to connect a telephone or modem to the wall jack. The connection to your PC serial port also requires a small black adaptor to convert the RJ11 to the DB9 connector of your PC serial port.

Your hub comes with a 7 foot cable, and each Si drive includes a 7 foot cable and a black adaptor. You can use longer cables, up to 50 feet. Telephone line cords are easily available at your local supermarket, discount or electronics store.

Note: never connect the SiNet hub to a telephone outlet or to the modem port of your PC.

Note: if you decide to make your own cables, make sure that the ends are terminated just like a telephone cord, as shown below. If you mess this up, you could seriously damage the hub, your drives or your PC. If in doubt, don't make your own cables.

