

D-24P

LINEAR ACTUATOR

WITH POTENTIOMETER



12 VDC SPEED VS LOAD

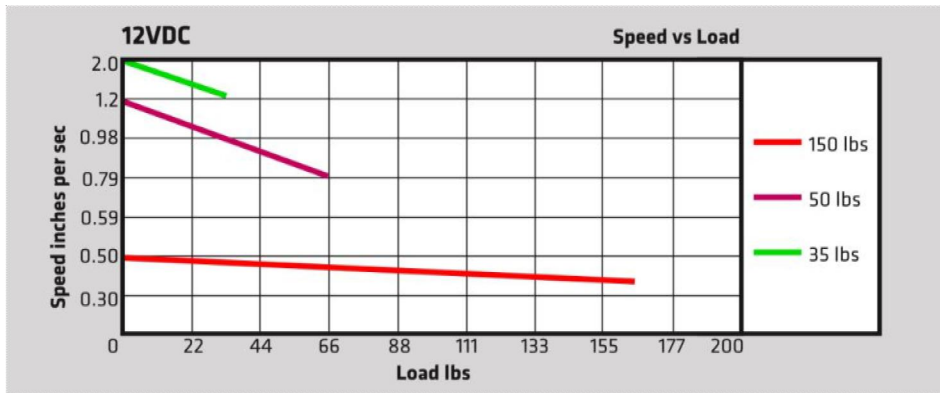

12 VDC CURRENT VS LOAD

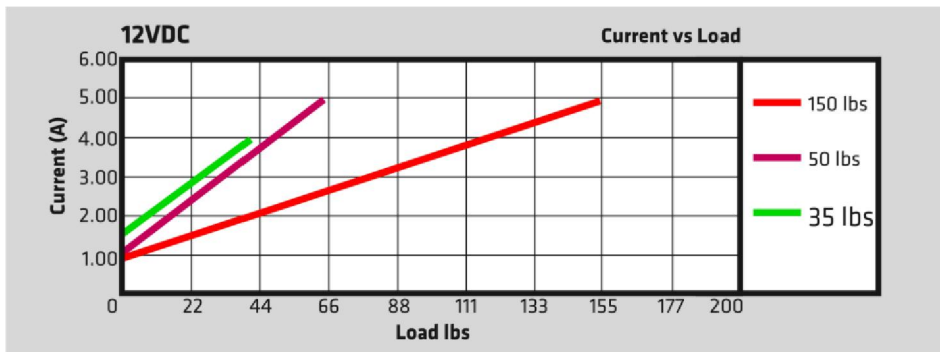

SPEED IN INCHES PER SECOND

Forces (lbs)	No Load	Full Load
35	2.00	1.20
50	1.18	0.94
150	0.59	0.51

HOLE TO HOLE DIMENSIONS

Stroke Sizes (in inches)	PA-14P Model Actuator	
	Fully Retracted (in inches)	Fully Extended (in inches)
0	5.51	5.51
1	6.51	7.51
2	7.51	9.51
3	8.51	11.51
4	9.51	13.51
6	11.51	17.51
8	13.51	21.51
9	14.51	23.51
10	15.51	25.51
12	17.51	29.51
14	19.51	33.51
16	21.51	37.51
18	23.51	41.51
20	25.51	45.51
22	27.51	49.51
24	29.51	53.51
30	35.51	65.51
40	45.51	85.51

PRODUCT ACCESSORIES

POTENTIOMETER

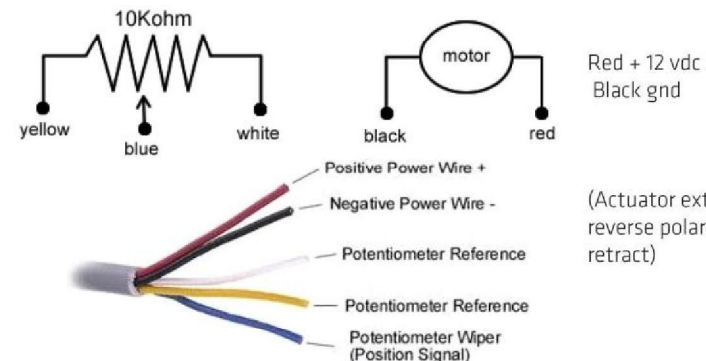

D-24P

LINEAR ACTUATOR

WITH POTENTIOMETER



ACTUATOR INTERNALS

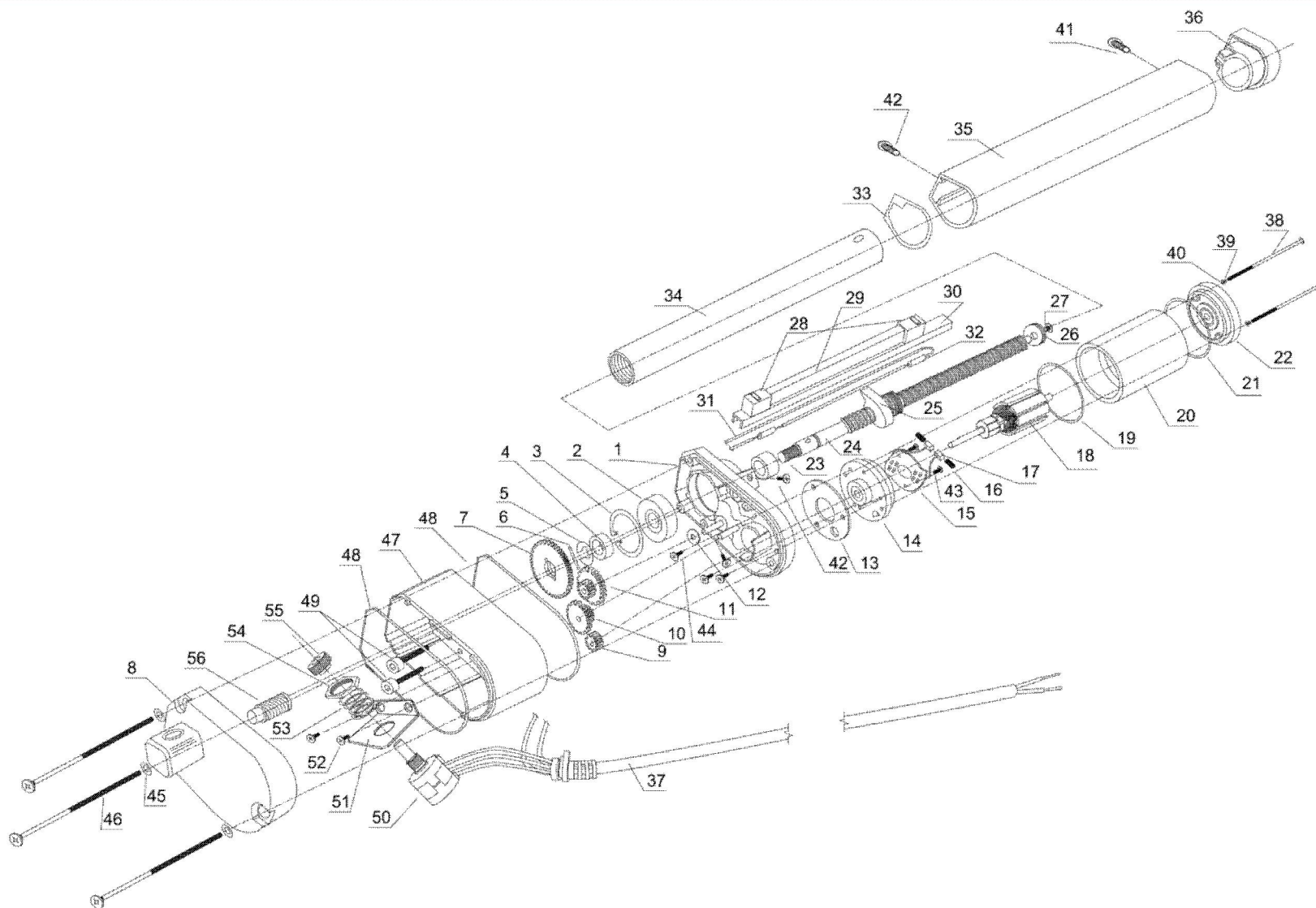

D-24P

LINEAR ACTUATOR

WITH POTENTIOMETER



ACTUATOR ASSEMBLY EXPANDED VIEW PARTS DESCRIPTION

Item	Description	Qty
1	Actuator base	1
2	Shaft Bearing	1
3	Shaft Bearing Lock	1
4	Shaft Base Spacer	1
5	Shaft Base Spacer Lock	1
6	Shaft Gear Wheel Holder	1
7	Shaft Gear Wheel	1
8	Base Cover with Mounting Support	1
9	Electric Motor Gear Wheel	1
10	Small Intermediate Gear Wheel	1
11	Medium Intermediate Gear Wheel	1
12	Teflon Washer	1
13	Electric Motor Base Washer	1
14	Electric Motor Base	1
15	Brush Holder PCB	1
16	Electric Motor Brush	2
17	Electric Motor Brush Spring	2
18	Electric Motor Rotor	1
19	Motor Enclosure Bottom Washer	1

Item	Description	Qty
29	Limit Switches Spacer	1
30	Limit Switches Base	1
31	Limit Switches Wiring	1
32	Diode	2
33	Shaft Encloser Bottom Washer	1
34	Shaft with Mounting Hole	1
35	Shaft Encloser	1
36	Shaft Enclosure Top Cap	1
37	Power Cable	1
38	Motor Enclosure Screw	2
39	Motor Screw Spring Washer	2
40	Motor Screw Washer	2
41	Shaft Enclosure Top Cap Screw	1
42	Shaft Enclosure Base Screw	3
43	Brush Holder PCB Screw	2
44	Motor Base Screw	3
45	Base Cover Washer	3
46	Base Cover Screw	3
47	Base Extension	1



20	Electric Motor Encloser with Stator	1
21	Motor Enclosure Top Washer	1
22	Electric Motor Cap with Rotor Bearing	1
23	Shaft Spacer	1
24	Treaded Shaft Drive / Lead Screw	1
25	Shaft Base with Limit Switches Arm	1
26	Shaft Drive End Support	1
27	Shaft Drive End Support Screw	1
28	Limit Switch	2

48	Base Extension gasket	2
49	Base Extension Screw	2
50	Potentiometer	1
51	Potentiometer Bracket	1
52	Potentiometer Bracket Screw	2
53	Potentiometer Washer	3
54	Potentiometer Nut	1
55	Potentiometer Gear	1
56	Shaft Gear	1