



KTC-LAJ-xx-xxx-xxx

V - LOAD - STROKE

Actuator Linear LAJ



Contents

Specifications	2
Dimensions	3
Speed/Current vs Load	4
Connectors & Feedback	5
Mounting Brackets	6
Internal Components	7
Internal Descriptions	8

Specifications

Load (LBS)		No Load Current (A)				Full Load Current (A)				Speed (inch/sec)	
Dynamic	Static	12VDC	24VDC	36VDC	48VDC	12VDC	24VDC	36VDC	48VDC	No Load	Full Load
250	250	1.5	0.6	0.5	0.3	5.5	3.0	2.0	1.5	0.59	0.43
330	330	1.5	0.6	0.4	0.3	5.5	3.0	2.0	1.5	0.39	0.28
450	450	1.2	0.5	0.4	0.3	5.5	3.5	2.5	1.5	0.24	0.20

Stroke	1" to 40"
Limit Switch	Internal - Non-Adjustable
Limit Switch Feedback	Customizable
Screw Type	ACME Screw
Motor Type	Brushed DC Motor
Connector Type	See Page 5
Wire Length	40" (customizable)
Housing Material	6062 Aluminum Alloy
Rod Material	Stainless Steel
Gear Material	Polyformaldehyde
Color (Shaft)	Silver
Color (Motor End)	Black or White
Noise	<45dB
Duty Cycle	25% (5 minutes on, 15 minutes off)
Operational Temperature	-25°C to 65°C (-13°F to 149°F)
Protection Class	IP66
Feedback Options	Hall Effect or Limit Switch Feedback (See Page 5)
Certifications	CE/RoHS/ISO-9001-2008
Mounting Brackets	See Page 7
Mounting Ends	Customizable

Dimensions

(Dimensions in inches)

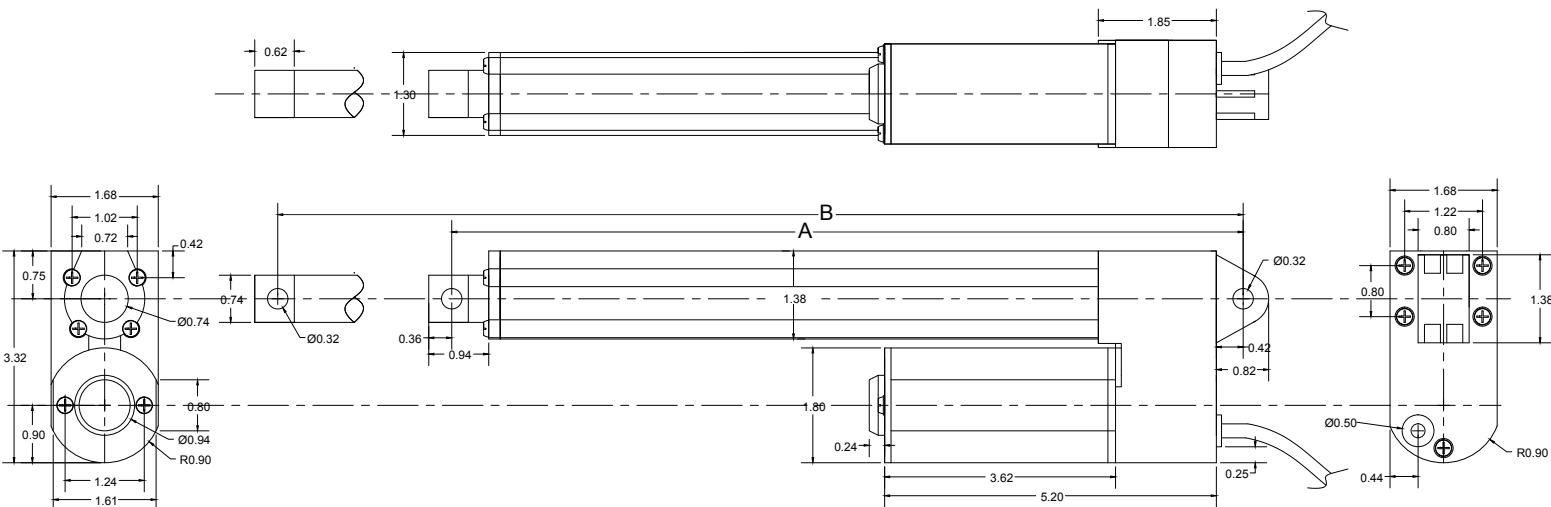

Hole to Hole

PA-09	Stroke	1	2	3	4	6	8	9	10	12	14	16	18	20	22	24	30	40
	A	5.50	6.50	7.50	8.50	10.50	12.50	13.50	14.50	17.75	19.75	21.75	23.75	25.75	27.75	30.50	36.50	48
B	6.50	8.50	10.50	12.50	16.50	20.50	22.50	24.50	29.75	33.75	37.75	41.75	45.75	49.75	54.50	66.50	88	

For Stroke Length Less Than 12"

$$A = \text{Stroke Length} + 4.50"$$

$$B = \text{Stroke Length} \times 2 + 4.50"$$

For Stroke Length of 12" up to 24"

$$A = \text{Stroke Length} + 5.75"$$

$$B = \text{Stroke Length} \times 2 + 5.75"$$

For Stroke Length 24" up to 30"

$$A = \text{Stroke Length} + 6.50"$$

$$B = \text{Stroke Length} \times 2 + 6.50"$$

For Stroke Length 30" to 40"

$$A = \text{Stroke Length} + 8.00"$$

$$B = \text{Stroke Length} \times 2 + 8.00"$$

Speed vs Load

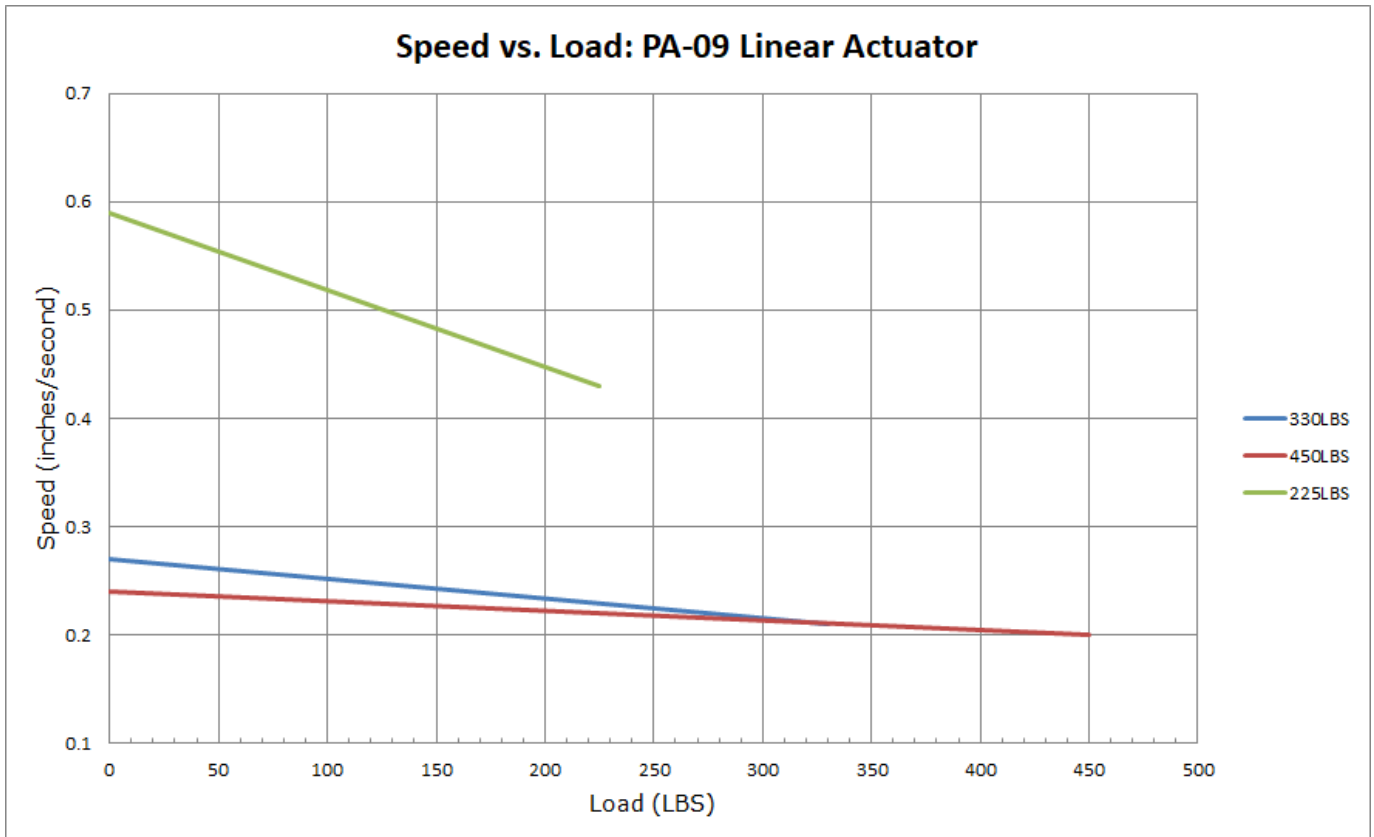

Current vs Load

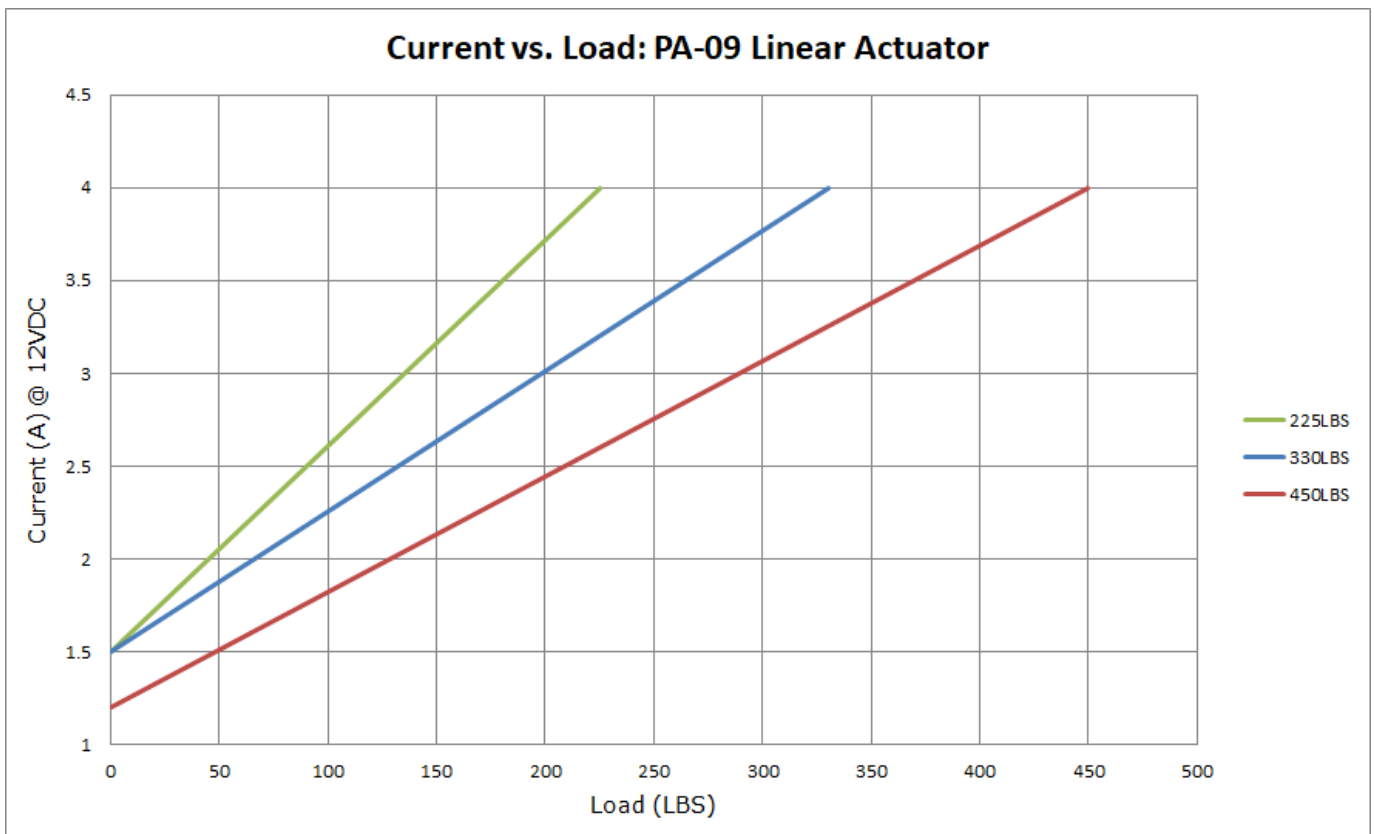

2-Pin Connector (Standard)

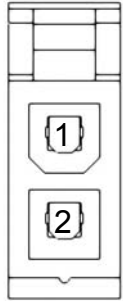

Motor	
1	2
M-	M+

Component	Part Name	Part Number	Mating Part Number
Housing	Molex Mini Fit Jr 2-Pin Receptacle	39-01-2025	39-01-2029 /39-01-2026

6-Pin Hall Effect Connector

*For Stroke Length up to 40"

Front View

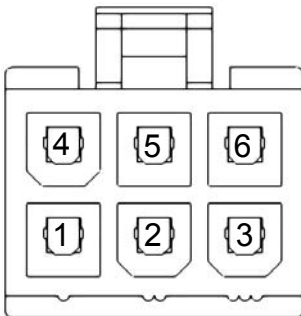

Motor		Hall Sensor			
4	5	2	3	1	6
M+ (Extend)	M- (Retract)	GND	+5VDC	Signal 2 Leads when Extending	Signal 1 Leads when Retracting

Component	Part Name	Part Number	Mating Part Number
Housing	Molex Mini Fit Jr 6-Pin Receptacle	39-01-2065	39-01-2069/ 39-01-2066

Output Signal Extending		Output Signal Retracting	
Hall Effect 1 Signal		Hall Effect 1 Signal	
Hall Effect 2 Signal		Hall Effect 2 Signal	

Force	Resolution (pulses/inch)
250	160
330	650
450	433

Mounting Brackets

(Dimensions in inches)

BRK-09

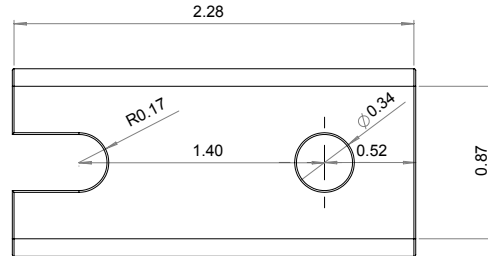
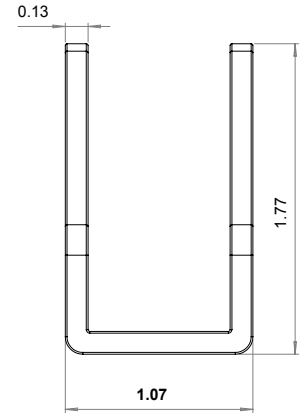
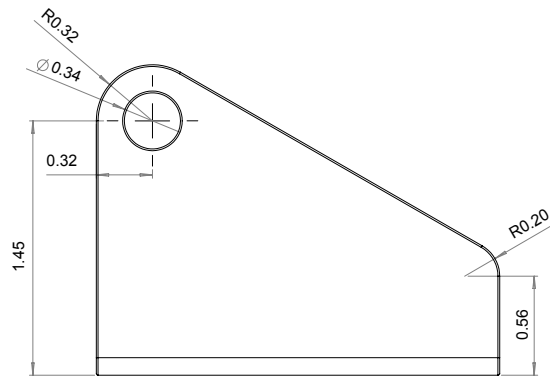

BRK-10

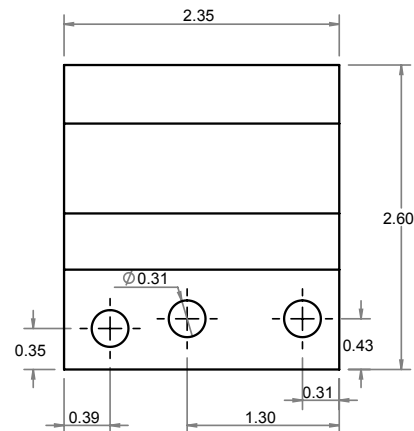
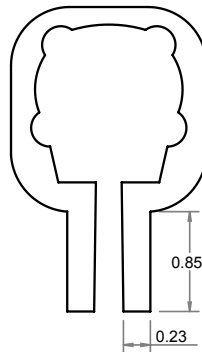
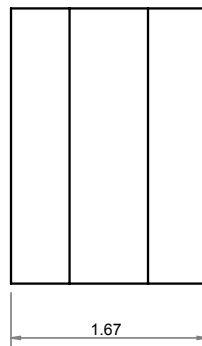

Internal Components

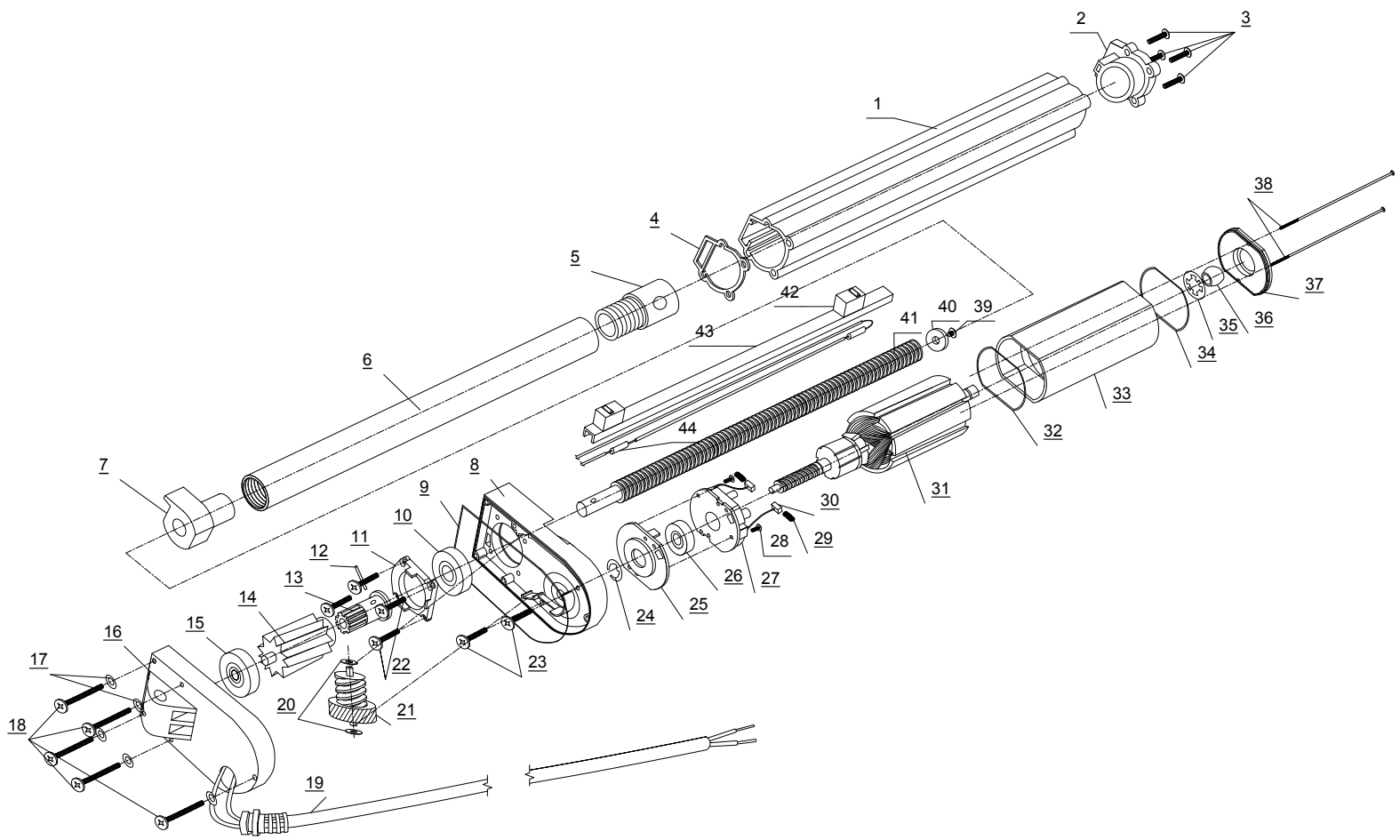

Internal Descriptions

Item	Description	Qty
1	Actuator Enclosure	1
2	Power Cable With Mounting	1
3	Power Cable Screw	2
4	Case Mounting Bracket	1
5	Mounting Bracket Screw	4
6	Mounting Bracket O-Ring	1
7	Motor Unit Screw Washer	2
8	Motor Unit Screw Spring Washer	2
9	Motor Unit Screw	2
10	Motor Case Gasket	1
11	Motor Base	1
12	Motor Lower Bearing	1
13	Brush Holder PCB	1
14	Capacitor	2
15	Inductor	2
16	Cable Lock	1
17	Cable Lock Screw	1
18	Electric Motor Brush	2
19	Brush Spring	2
20	Electric Motor Rotor	1
21	Electric Motor Enclosure With Stator	1
22	Top Bearing Holder	1
23	Top Bearing	1
24	Motor Top Enclosure	1
25	Motor Screw Washer	2

Item	Description	Qty
26	Motor Screw	2
27	Actuator Top Cap	1
28	Shaft Enclosure Side Screw	2
29	Shaft Enclosure Side Screw Nut	2
30	Shaft Enclosure Protector	1
31	Bottom Shaft Guide	1
32	Shaft	1
33	Shaft Mounting Top	1
34	Mounting Hole Guard	2
35	Wire	1
36	Diode	2
37	Limit Switch	2
38	Limit Switch Base	1
39	Drive Gear Wheel Pin	2
40	Shaft Drive Bottom Bearing	1
41	Drive Gear Wheel	1
42	Shaft Drive Bearing	1
43	Shaft Drive Small Spacer	1
44	Shaft Drive Spacer	1
45	Treaded Shaft Drive	1
46	Shaft Enclosure Screw	1
47	Shaft Enclosure	1
48	Shaft Enclosure Top Cap	1
49	Shaft Enclosure Top Cap Screw	1
50	Rotor Control Screw	1