

MACHINE SCREW ACTUATORS 10 TON CAPACITY

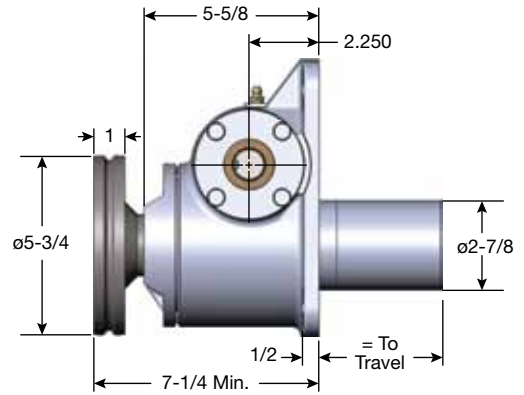

Upright: M-9010

2" Diameter x .500 Lead Lifting Screws

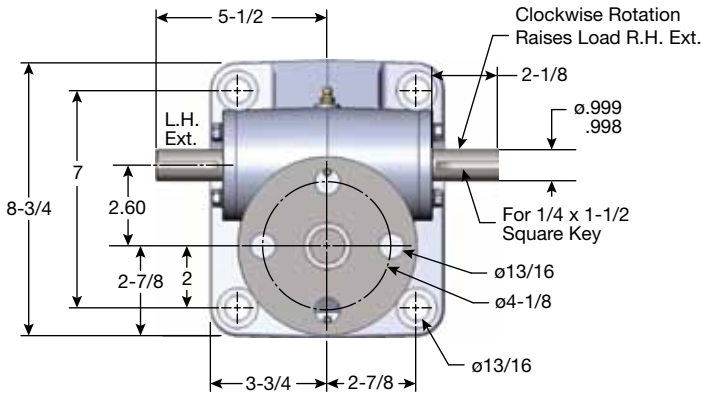
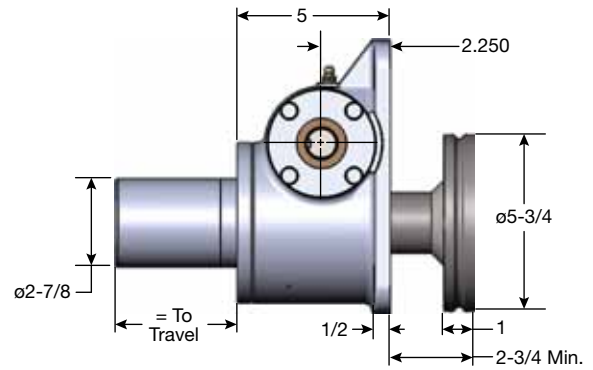
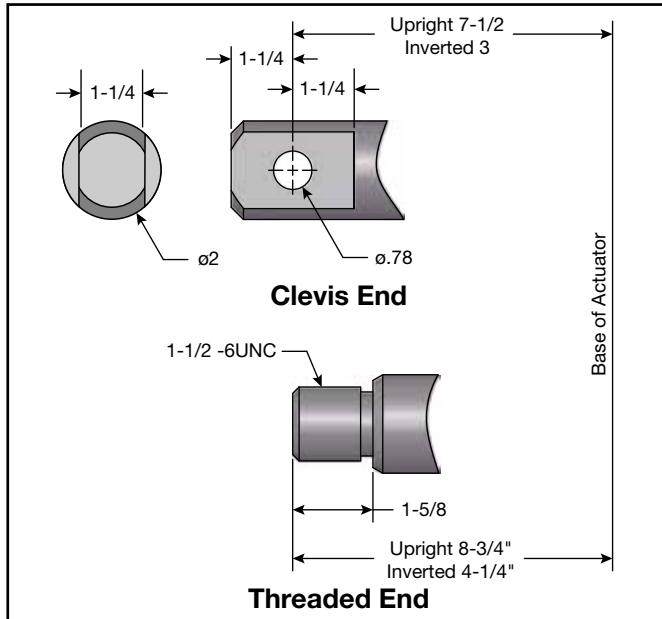

Inverted: M-9009

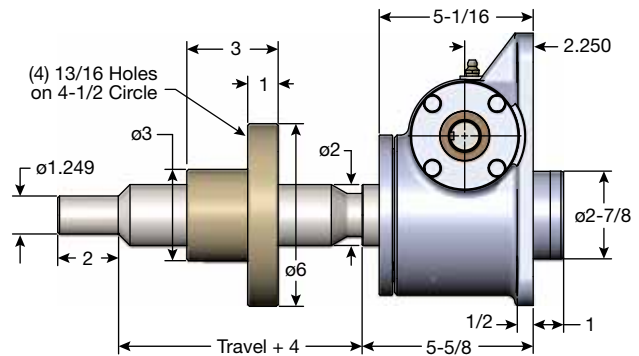

Upright Rotating: UM-9011

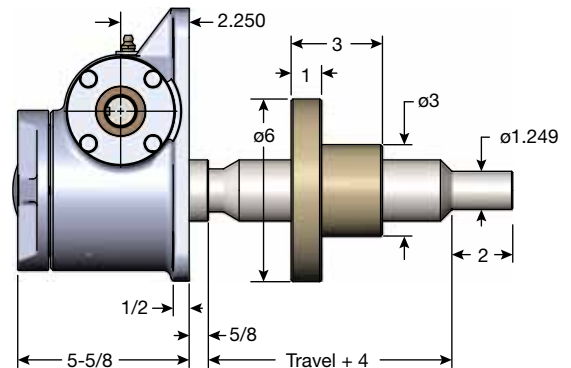

Inverted Rotating: DM-9011

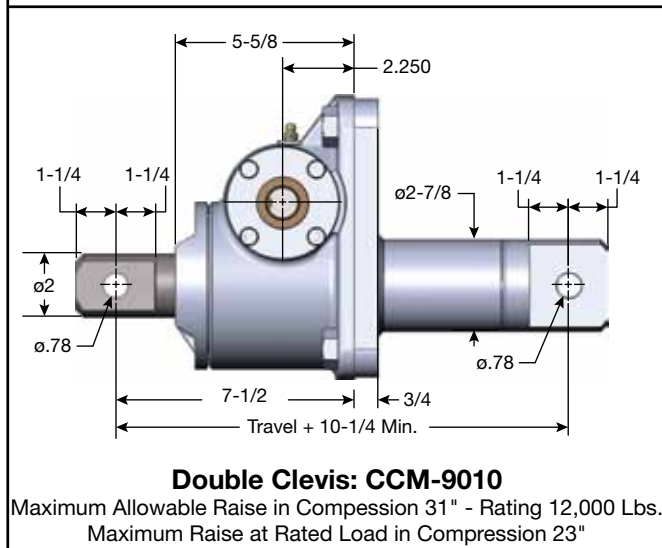

Note: Lifting screw is not keyed. Top should be secured to a lifting member to prevent rotation. When a Bellows Boot is required, see pages 148-149. Dimensions are subject to change without notice.