

MACHINE SCREW ACTUATORS

100 TON CAPACITY

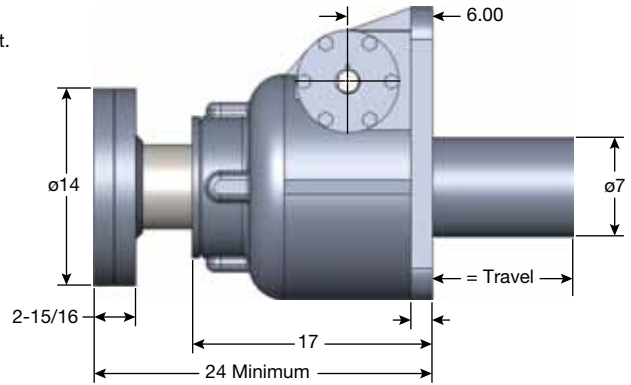
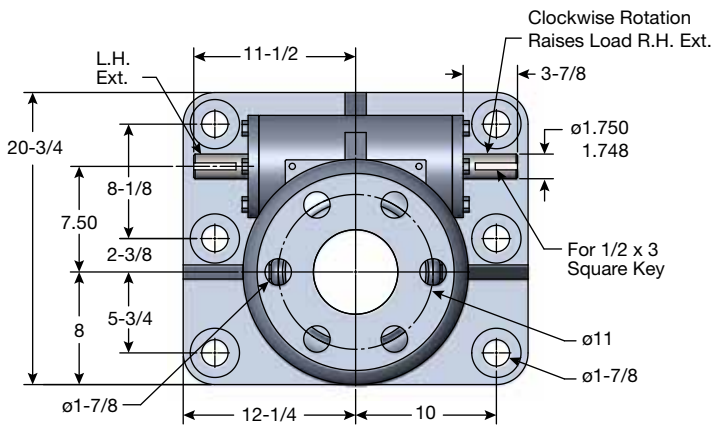

Upright: M-9099

6" Diameter x .750 Lead Lifting Screws

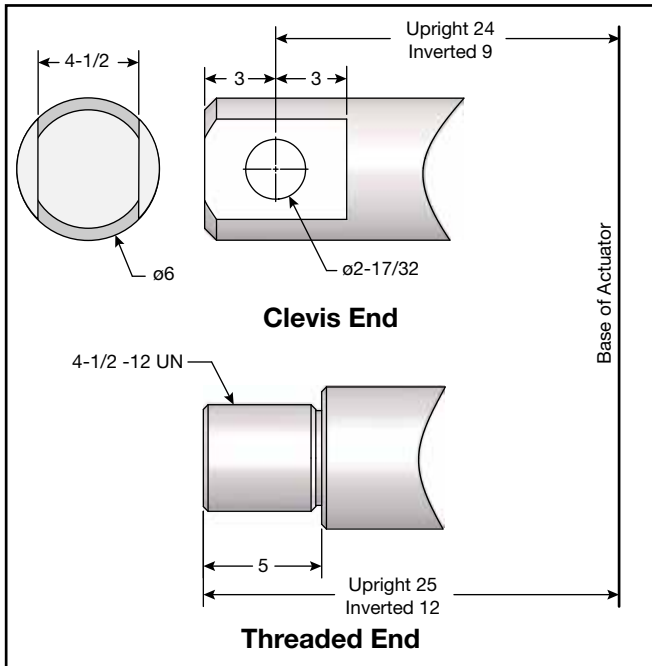

Note: Lifting screw is not keyed. Top should be secured to a lifting member to prevent rotation. When a Bellows Boot is required, see pages 148-149. Dimensions are subject to change without notice.

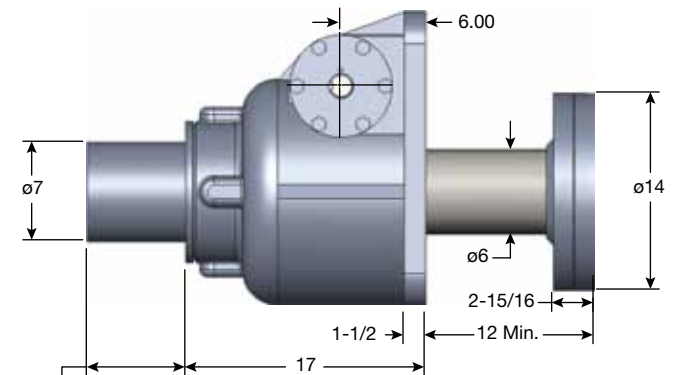

Inverted: M-9098

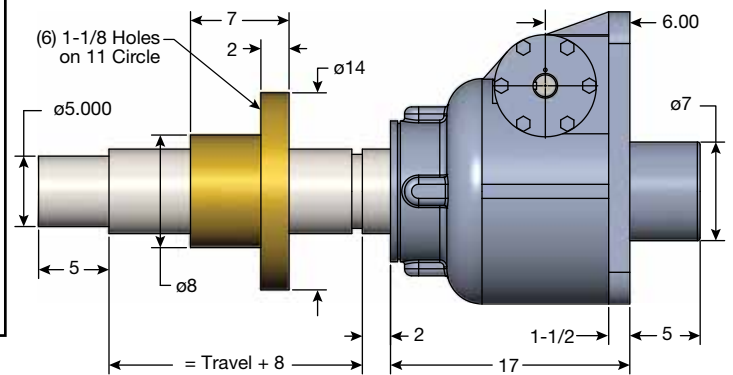

Upright Rotating: UM-9097

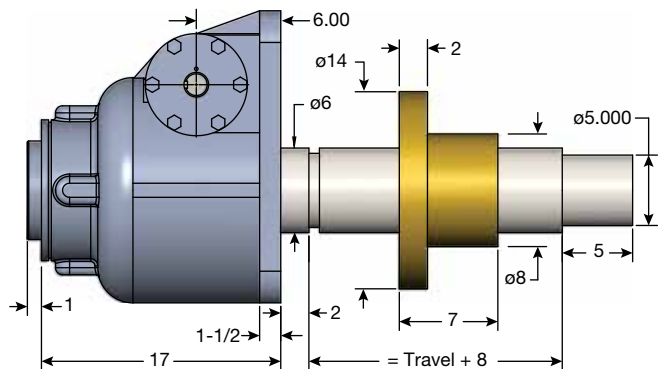

Inverted Rotating: DM-9097