

MACHINE SCREW ACTUATORS

15 TON CAPACITY

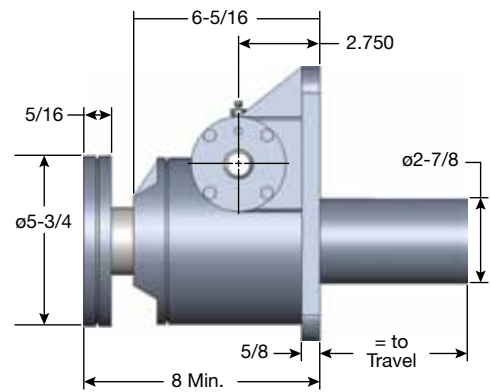
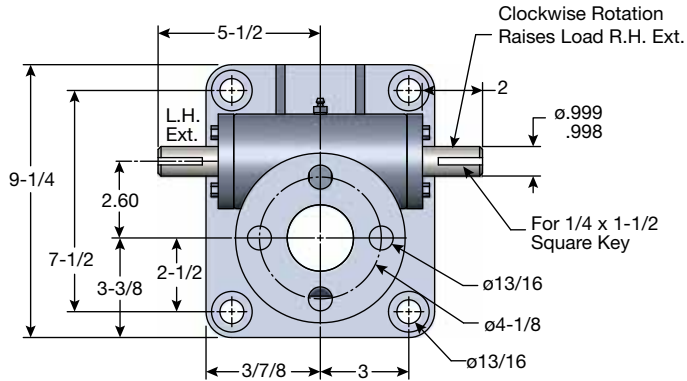

Upright: M-9015

2-1/4" Diameter x .500 Lead Lifting Screws

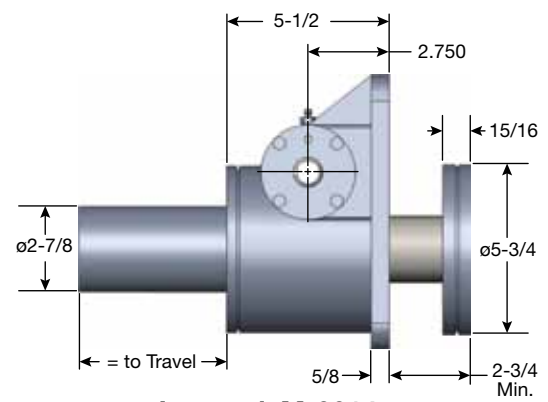
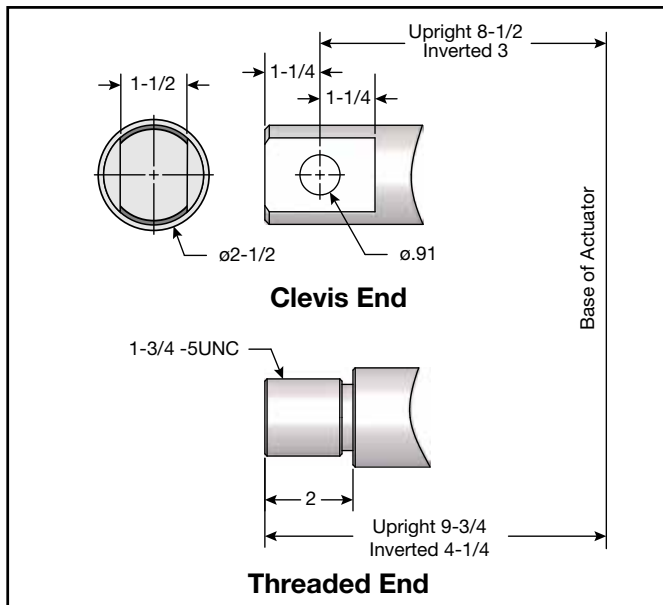

Inverted: M-9014

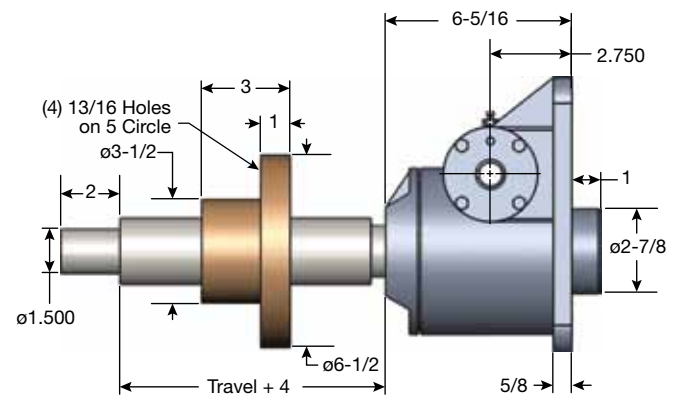

Upright Rotating: UM-9016

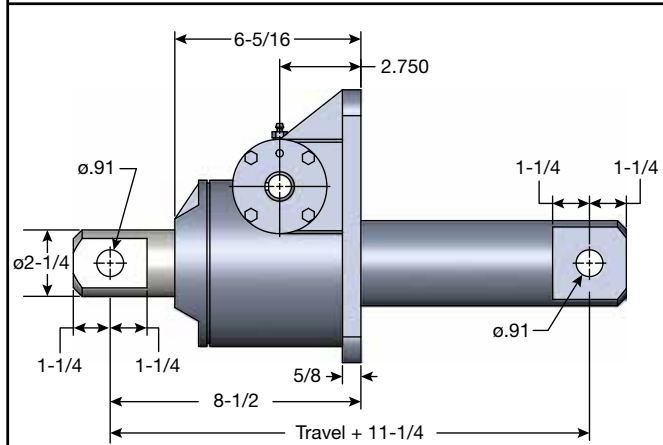

Double Clevis: CCM-9015

Maximum Allowable Raise in Compression 37" - Rating 16,000 Lbs.
Maximum Raise at Rated Load in Compression 26"

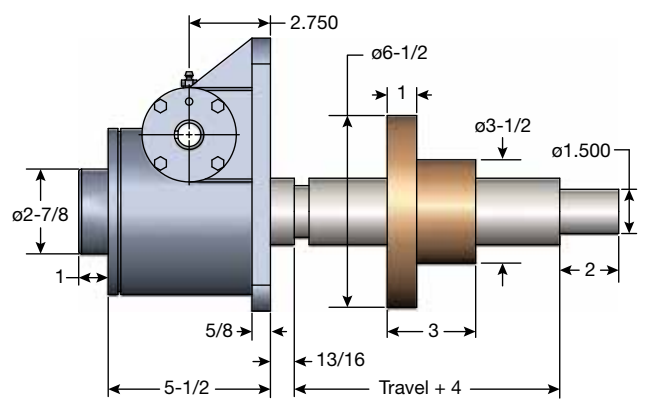

Inverted Rotating: DM-9016

Note: Lifting screw is not keyed. Top should be secured to a lifting member to prevent rotation. When a Bellows Boot is required, see pages 148-149. Dimensions are subject to change without notice.