

EP Series Electro Pack

Base Mounted Clutch/Brake Combinations in a Rugged Housing

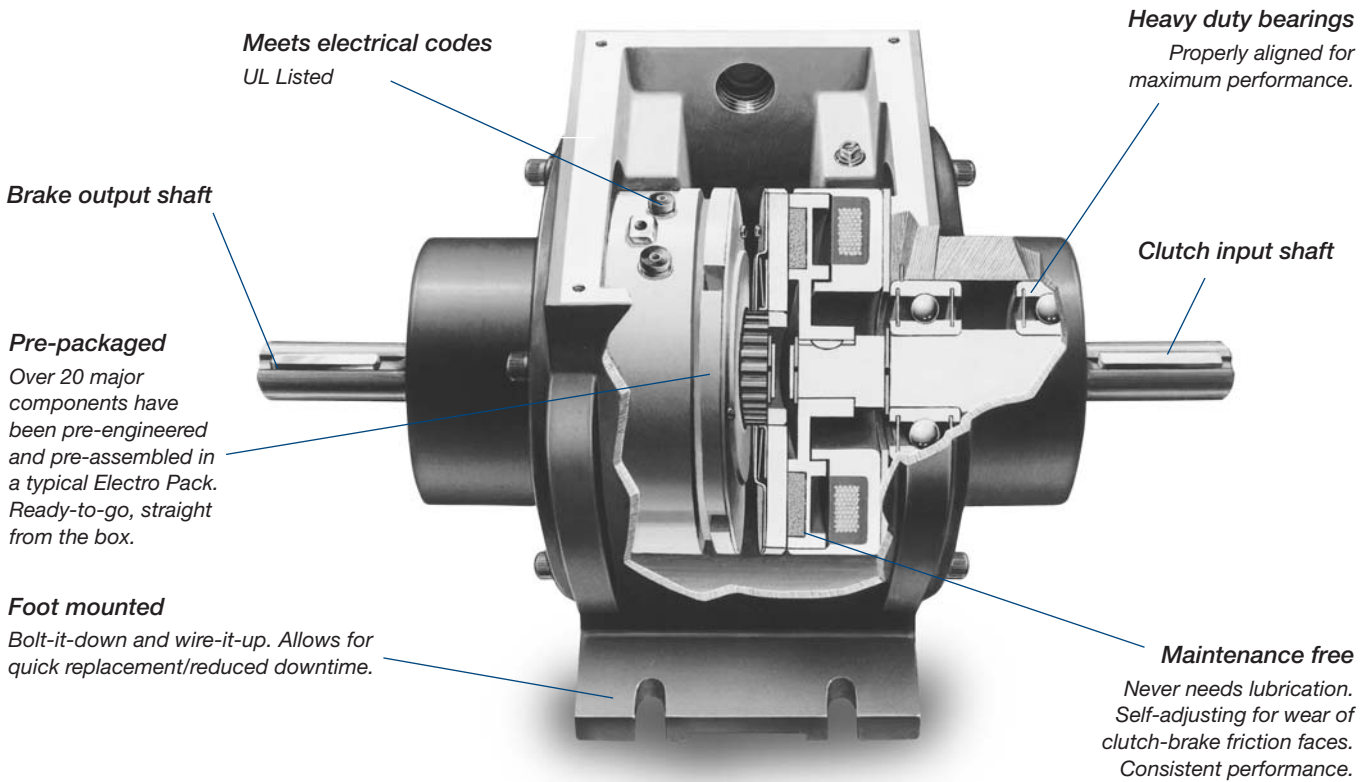

Electro Packs are rugged, pre-assembled clutch and brake combinations in an enclosed, foot mounted housing.

They are factory aligned and pre-assembled and have been designed to mate easily with industry standard motors and reducers with v-belts, pulleys, chain and sprockets, in line couplings and timing belt drives.

Features

- Bolt-it-down and wire-it-up . . . it's ready to go!
- Maintenance free
- A wide torque range from 15 lb. in. to 1350 lb. ft.

Typical Application

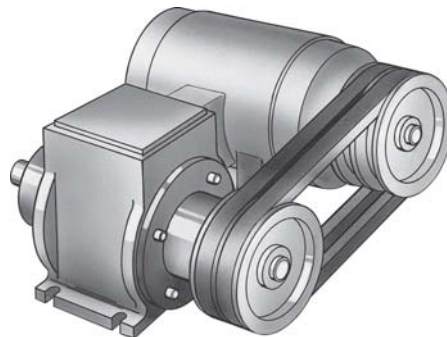

A foot mounted Electro Pack combines with a motor in a parallel shaft drive application.

Selection/Ordering Information

Horsepower vs. Shaft Speed

HP ▼	SHAFT SPEED AT CLUTCH (IN RPM)																					
	100	200	300	400	500	600	700	800	900	1000	1100	1200	1500	1800	2000	2400	3000	3600	4000	4500	5000	
1/50																						
1/20																						
1/12																						
1/8																						
1/6																						
1/4																						
1/3																						
1/2																						
3/4																						
1																						
1-1/2																						
2																						
3																						
5																						
7-1/2																						
10																						
15																						
20																						
25																						
30																						
40																						

Selection Procedure

Determine the shaft speed at the Electro Pack location. The number listed at the intersection of horsepower and speed is the size Electro Pack you require.

Part Numbers

Model No.	Voltage		Part No.
	DC		
EP-170	6		5633-273-002
	24		5633-273-003
	90		5633-273-005
EP-250	6		5130-273-031
	24		5130-273-032
	90		5130-273-034
EP-400	6		5131-273-009
	24		5131-273-010
	90		5131-273-011
EP-500	6		5230-273-003
	24		5230-273-011
	90		5230-273-002
EP-825	6		5231-273-003
	24		5231-273-004
	90		5231-273-002
EP-1000	6		5232-273-003
	24		5232-273-005
	90		5232-273-002
EP-1525	6		5234-273-003
	90		5234-273-002
EP-1525HT	24		5234-273-017
	90		5234-273-012

When ordering, specify size, voltage, and part numbers.

Specifications

Electro-Pack Size	Horsepower @ 1800 RPM	Static Torque	Max. RPM	Voltage DC
EP-170	1/8	15 lb. in.	10,000	6, 24 or 90
EP-250	1/2	70 lb. in.	7,500	6, 24 or 90
EP-400	1	270 lb. in.	4,500	6, 24 or 90
EP-500	2	50/40 lb. ft.	4,000	6, 24 or 90
EP-825	7-1/2	125 lb. ft.	3,600	6, 24 or 90
EP-1000	10	240 lb. ft.	3,000	6, 24 or 90
EP-1525	25	700 lb. ft.	1,800	6 or 90
EP-1525HT	40	1350 lb. ft. clutch 700 lb. ft. brake	1,800	24, 90

EP Series Electro Pack

EP-170, EP-250, EP-400

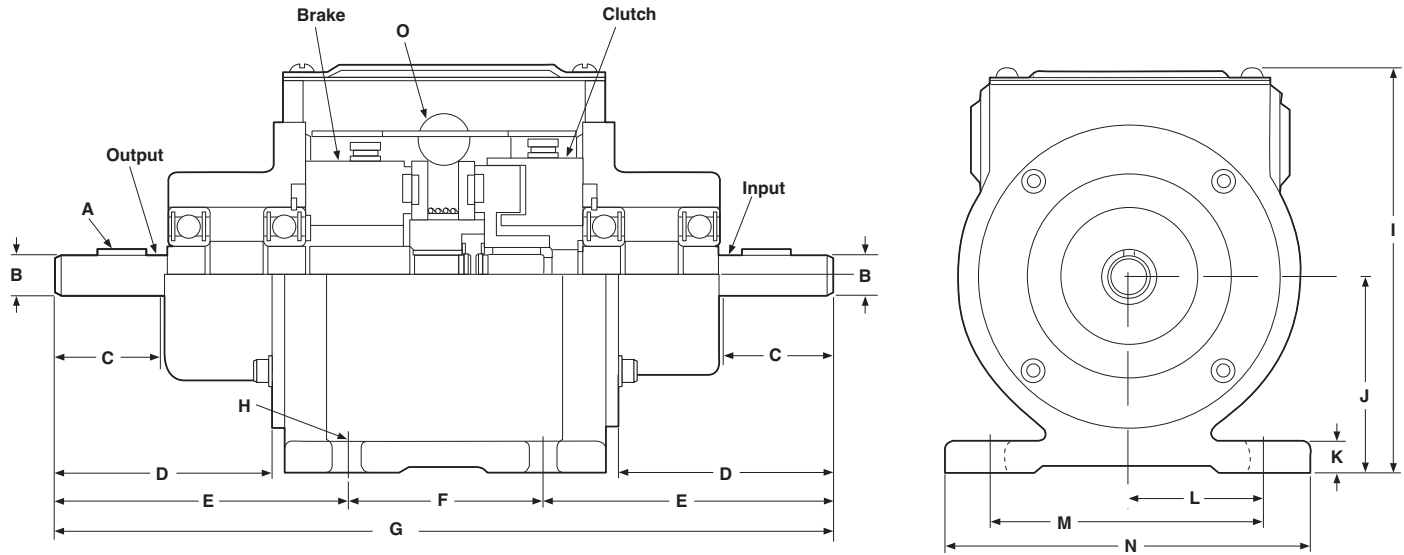

Dimensions

All dimensions are nominal, unless otherwise noted.

Size	A	B	C Min.	D	E	F	G Max.	H	I	J	K	L	M	N	O
170	3/32 x 3/64	.3745 .3735 Dia.	.750	1.406	2.203	1.500	6.000	.250 Wide (4 slots)	3.437	1.662 1.652	.312	1.110	2.220	3.250	1/2 14 NPT Conduit x 2
250	1/8 x 1/16	.4995 .4985 Dia.	1.250	2.468	3.312	2.250	8.968	.312 Wide (4 slots)	5.281	2.318 2.308	.375	1.625	3.250	4.250	1/2 14 NPT Conduit x 2
400	3/16 x 3/16 x 1-1/2	.7495 .7485 Dia.	1.875	3.515	4.593	2.500	11.781	.312 Wide (4 slots)	6.937	3.474 3.464	.500	2.578	5.156	6.000	1/2 14 NPT Conduit x 2

Specifications

Model Size	Voltage DC	Static Torque lb. in.	Inertia*—WR ² (lb-in ²)		Max. RPM	Weight lbs.
			Output	Input		
EP-170	6	15	.031	.036	10,000	2.5
	24	15	.031	.036	10,000	2.5
	90	15	.031	.036	10,000	2.5
EP-250	6	70	.331	.293	7,500	7.1
	24	70	.331	.293	7,500	7.1
	90	70	.331	.293	7,500	7.1
EP-400	6	270	2.566	2.222	4,500	19.7
	24	270	2.566	2.222	4,500	19.7
	90	270	2.566	2.222	4,500	19.7

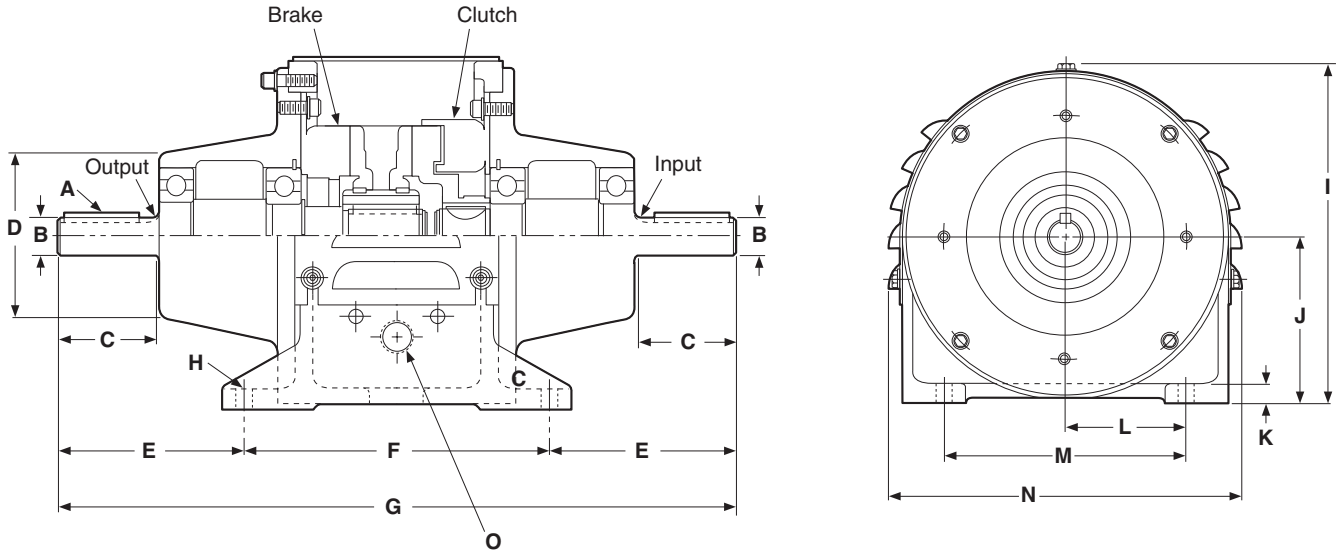

Dimensions

All dimensions are nominal, unless otherwise noted.

Size	A	B Dia.	C Min.	D Max. Dia.	E	F	G Max.	H Dia.	I	J	K	L	M	N Max.	O
500	3/16 x 1-3/4	.8750	2.218	3.796	4.234	7.000	15.515	.406 (4 holes)	8.218	4.004	.500	2.937	5.875	8.734	1/2 NPT Conduit x 2

Specifications

Model Size	Voltage DC	Unit	Static Torque	Inertia*-WR ² lb.ft. ²	Max. RPM	Weight lbs.
EP-500	6, 24 and 90	Clutch Brake	50 40	.039 .063	4000	56

EP Series Electro Pack

EP-825

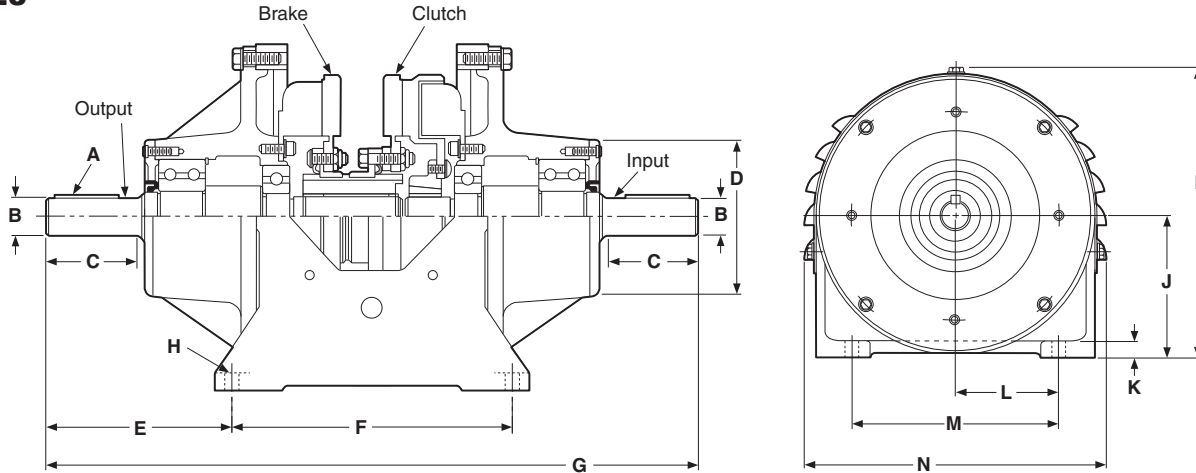

Dimensions

All dimensions are nominal, unless otherwise noted.

Size	A	B Dia.	C Min.	D Max. Dia.	E	F	G Max.	H	I	J	K	L	M	N Max.
825	1/4 x 1/4 x 2	1.1250 1.1245	2.875	5.000	5.734	8.500	20.031	.406 Dia. (4 holes)	10.812	5.254 5.252	.562	4.250	8.500	11.609

Specifications EP-825

Model Size	Voltage DC	Unit	Static Torque	Inertia*-WR ² lb.ft.2	Max. RPM	Weight lbs.
EP-825	6, 24 & 90	Clutch	125	.651	3600	123
		Brake	125	.242		

EP-1000

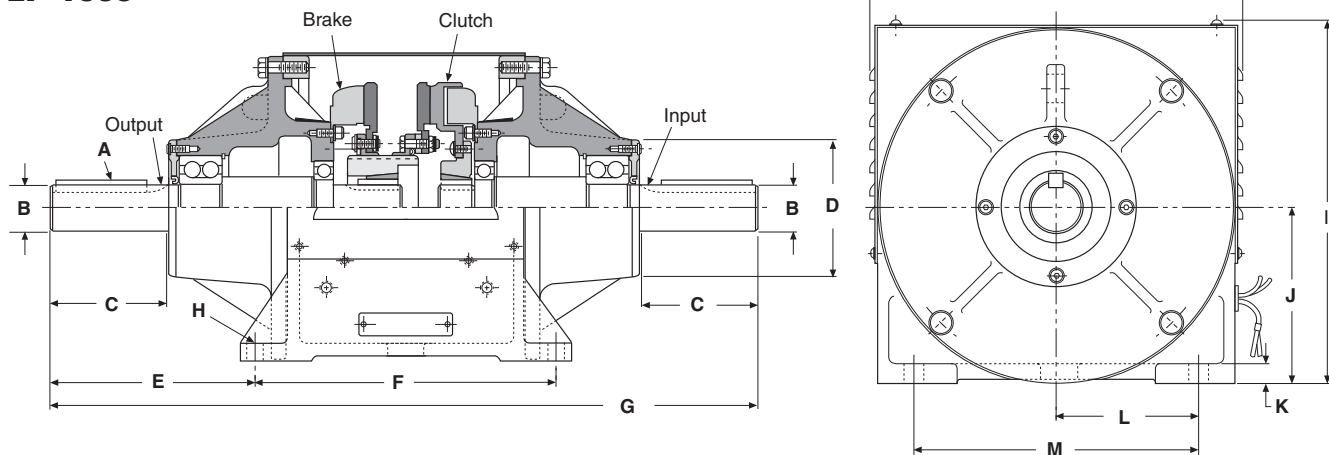

Dimensions

All dimensions are nominal, unless otherwise noted.

Size	A	B Dia.	C Min.	D Dia.	E	F	G Max.	H	I	J	K	L	M	N Max.
1000	1/2 x 1/2 x 3-3/4	1.875 1.874	4.750	5.687	8.250	12.250	28.750	.656 Dia. (4 holes)	12.500	6.255 6.241	.718	5.000	10.000	12.875

Specifications EP-1000

Model Size	Voltage DC	Static Torque	Inertia*-WR ² (lb-ft ²)		Max. RPM	Weight lbs.
			Output Side	Input Side		
EP-1000	6	240 lb.ft.	1.45	1.01	3000	288
	24	240 lb.ft.	1.45	1.01	3000	288
	90	240 lb.ft.	1.45	1.01	3000	288

EP Series Electro Pack

EP-1525, EP-1525HT

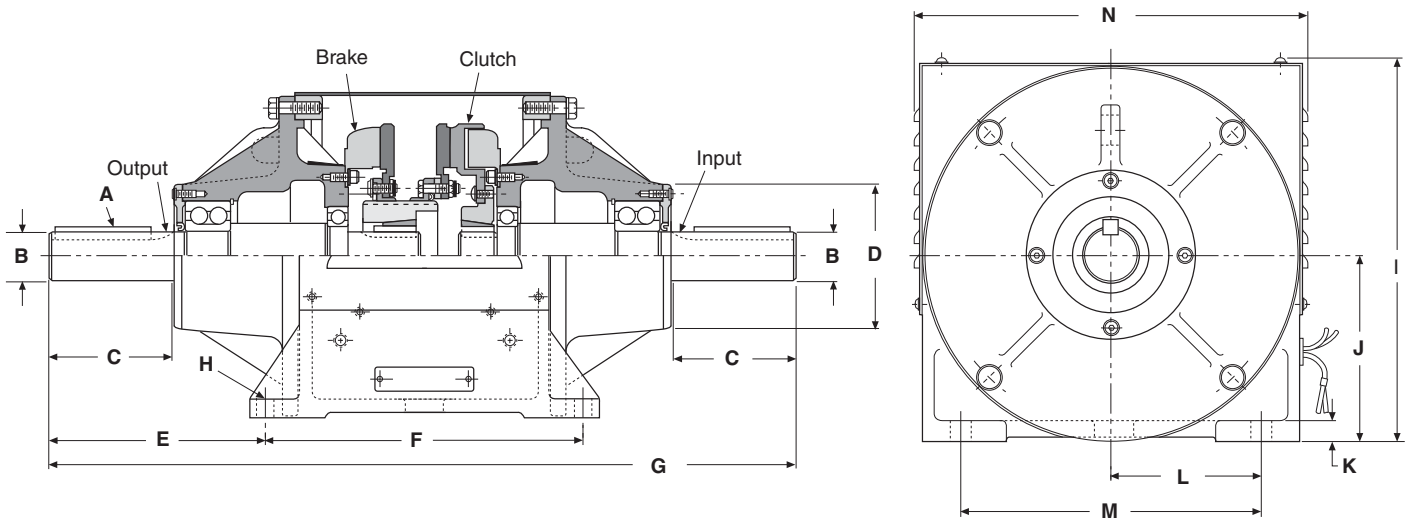

Dimensions

All dimensions are nominal, unless otherwise noted.

Size	A	B Dia.	C Min.	D Max. Dia.	E	F	G Max.	H	I	J	K	L	M	N Max.
1525	5/8 x 5/8 x 4-1/4	2.375 2.374	5.750	7.500	8.468	16.500	33.500	.796 Dia. (4 holes)	18.250	9.005 8.991	1.000	7.000	14.000	18.875
1525HT	5/8 x 5/8 x 4-1/4	2.375 2.374	5.750	7.500	8.468	16.500	33.500	.796 Dia. (4 holes)	18.250	9.005 8.991	1.000	7.000	14.000	18.875

Specifications

Model Size	Voltage DC	Unit	Static Torque lb.ft.	Inertia* -WR ² lb.ft. ²		Max. RPM	Weight lbs.
				Output	Input		
EP-1525	6, 90	Clutch Brake	700 700	7.89	5.68	1800	655
EP-1525HT	24, 90	Clutch Brake	1350 700	7.89	6.41	1800	656