

UM Series UniModule

Pre-assembled, C-face Clutches and Brakes

UniModules offer the ultimate in Clutch/ Brake performance and convenience. UniModules offer the same performance as EM's without the assembly required.

Completely pre-assembled one-piece clutch and clutch/brake packages in five sizes. Can be motor or reducer mounted or used as a separate drive unit powered by a prime mover.

Pre-assembled, pre-aligned, and pre-burnished at the factory for rated torque directly out-of-the-box.

- Easy installation
- Available with standard power-on and electrically released power-off brake units
- Fan cooled for high cycle rate operation
- Maintenance Free
- Available in 50, 100, 180, 210, and 215 sizes. NEMA C-face design
- UL listed
- Can be applied with control fitted as standard
- Bearing mounted clutch rotor eases assembly alignment
- Single access hole for all wires



GEN 2 Design

Sizes 50, 100 & 180

Original Design

Sizes 210 & 215

UniModule Combinations

Clutch Combinations



1040

Motor Clutch/Output Clutch

Use for clutch only applications. Has hollow bore input for mounting directly to C-face motors. Shaft and C-face on output side of unit accommodates reducer, parallel drive or coupling. Motor Clutch is fan cooled for long life and consistent performance. Basic components are field, rotor and armature. See page 21 in this catalog.



3040

Input Clutch/Output Clutch

Use for clutch only applications. Features dual C-faces and shafts. Unit input from parallel drive or coupling. Output to reducer. Input Clutch is fan cooled and has sealed coil. Twin bearing mounted shafts maintain tight concentricities. The Output Clutch utilizes Autogap™ which automatically adjusts armature for wear. Basic components are field, rotor and armature. See page 23 in this catalog.



3040-B

Input Clutch/Output Clutch – with Accessory Base Mounting

Base mounting allows the clutch unit to be utilized as a separate drive unit. Attach with pulleys, sprockets, etc. See page 23 in this catalog.

Clutch/Brake Combinations



1020

Motor Clutch/Brake

Use for clutch/brake applications. Has hollow bore input for mounting directly to C-face motors. Brake shaft and C-face on output side accommodate a reducer, parallel drive or coupling. Basic components: field, rotor, 2 armatures and power-on magnet. See page 20 in this catalog.

Heavy-duty models available with increased spline length and higher load capacity bearings.



2030

Input Clutch/Brake

Use for clutch/brake applications. Features dual C-faces and shafts. Input from parallel drive or coupling. Output to reducer. Basic components are field, rotor, 2 armatures and power-on magnet. See page 22 in this catalog.



2030-B

Input Clutch/Brake – with Accessory Base Mounting

Base mounting allows the clutch/brake units to be utilized as a separate drive unit. Attach with pulleys, sprockets, etc. See page 22 in this catalog.

UM Series UniModule

Selection

UniModule clutch, brake and clutch/brake units may be mounted directly to NEMA C-face motors and reducers, or can be base mounted.

1. Select Configuration

a. NEMA C-face Mounting

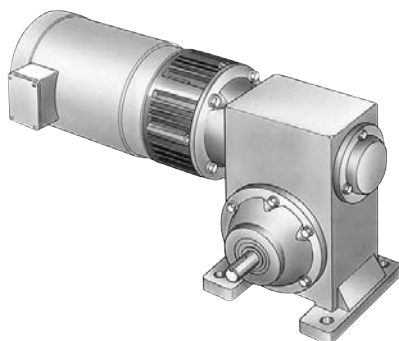

To select the correct UniModule package, determine the NEMA frame size of your motor and/or reducer, and choose the corresponding size UniModule from the Frame Size Selection chart.

Size UM-100 modules utilize a 5/8" diameter shaft to fit 56C/48Y motor frames with components of UM-180 units for higher torque and heat dissipation capacity than the UM-50.

UM-100 modules are available in 1020 and 2030 clutch/brake and 1040 and 3040 clutch configurations. For C-face mounting, select either a 1020 clutch/brake or a 1040 clutch configuration. The 2030 and 3040 configurations are for base mounting.

Frame Size Selection

| NEMA Frame Size | UniModule Size |
|-----------------|----------------|
| 56C/48Y | UM-50* |
| | UM-100** |
| 182C/143TC | UM-180 |
| 184C/145TC | |
| 213C/182TC | UM-210 |
| 215C/184TC | UM-215 |
| 213TC/215TC | |

* For 56C/48Y Frame motors 3/4 HP and smaller the UM-100 size may be used where extended life is desirable.

** UM-100 size is recommended for motors 1 HP and larger.

b. Base Mounting

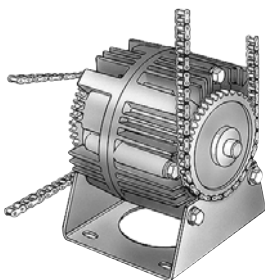

UniModule assemblies may be mounted as separate drive units driven from the prime mover by V-belts, chain and sprockets, couplings, timing belts and other standard power transmission components.

Select the correct size module from the Horsepower vs. Shaft Speed chart by determining the motor horsepower and RPM at the module location. The correct size UniModule is shown at the intersection of the HP and operating speed.

For additional sizing information, refer to the technical sizing procedure (step 2).

2. Determine Technical Requirements

Technical considerations for sizing and selection are torque and heat dissipation. Each merits careful consideration, especially heat dissipation as over time, use in excessive temperature environments will have an adverse effect on bearing life and coil wire insulation integrity.

Compare the calculated torque requirement with the average dynamic torque ratings. Select a unit with adequate torque. If the unit selected on torque is different than the unit selected based on heat, select the larger size unit.

Horsepower vs. Shaft Speed

| HP | SHAFT SPEED AT CLUTCH (IN RPM) | | | | | | | | | | | | | | | | | | |
|-------|--------------------------------|-----|-----|-----|-----|-----|-----|-----|-----|------|------|------|------|------|------|------|------|------|--|
| | 100 | 200 | 300 | 400 | 500 | 600 | 700 | 800 | 900 | 1000 | 1100 | 1200 | 1500 | 1800 | 2000 | 2400 | 3000 | 3600 | |
| 1/4 | | | | | | | | | | | | | | | | | | | |
| 1/2 | | | | | | | | | | | | | | | | | | | |
| 3/4 | | | | | | | | | | | | | | | | | | | |
| 1 | | | | | | | | | | | | | | | | | | | |
| 1-1/2 | | | | | | | | | | | | | | | | | | | |
| 2 | | | | | | | | | | | | | | | | | | | |
| 3 | | | | | | | | | | | | | | | | | | | |
| 5 | | | | | | | | | | | | | | | | | | | |
| 7-1/2 | | | | | | | | | | | | | | | | | | | |

a. Heat Dissipation Sizing

Friction surfaces slip during the initial period of engagement and, as a result, heat is generated. The clutch/brake selected must have a heat dissipation rating greater than the heat generated by the application. Therefore, in high inertia or high cycle rate applications, it is necessary to check the heat dissipation carefully. Inertia, speed and cycle rate are the required parameters.

Heat dissipation requirement is calculated as follows:

$$E = 1.7 \times WR2 \times (N/100)^2 \times F$$

where:

$$E = \text{Heat (lb. ft./min.)}$$

WR2 = Total reflected inertia at the clutch/brake shaft. Include the clutch/brake output inertia. (lb.ft.2)

N = Speed in revolutions per minute. (RPM)

F = Cycle rate in cycles per minute (CPM)

Compare the calculated heat generated in the application to the unit ratings using the heat dissipation curves. Select the appropriate unit that has adequate heat dissipation ability.

Heat Dissipation Curves

Size 50

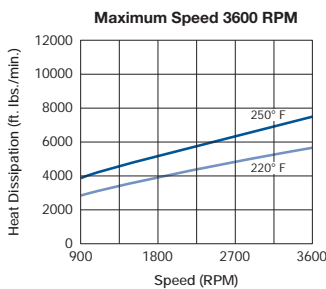

Size 100/180

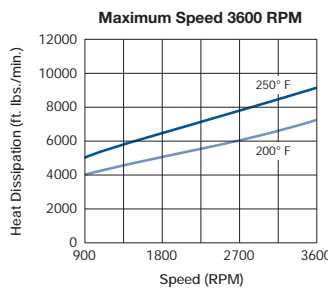

Size 210/215

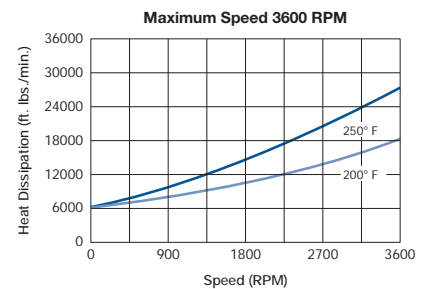

b. Torque Sizing

For most applications, the correct size clutch/brake can be selected from the Horsepower vs. Shaft Speed chart on page 16. Determine the motor horsepower and the RPM at the clutch/brake. The correct size unit is shown at the intersection of horsepower and shaft speed.

If the static torque requirements are known, refer to the technical ratings chart to select a unit.

For some applications, the torque requirement is determined by the time allowed to accelerate and decelerate the load. (This time is generally specified in milliseconds.) For these applications, it is necessary to determine the torque requirement based on load inertia and the time allowed for engagement.

The torque requirements are calculated as follows:

$$T = (WR2 \times N) / (308 \times t)$$

where:

T = Average Dynamic Torque (lb. ft.)

WR2 = Total reflected inertia at the clutch/brake shaft. Include the clutch/brake output inertia. (lb. ft.2)

N = Speed in revolutions per minute. (RPM)

t = Time allowed for the engagement (sec)

C-face Clutch/Power-on Brake Dynamic Torque Curves

Size 50

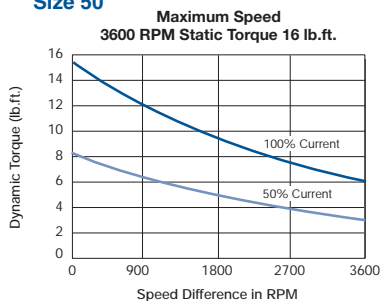

Size 100/180

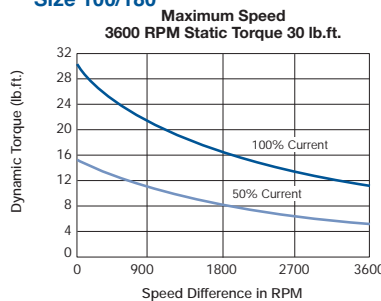

Size 210/215

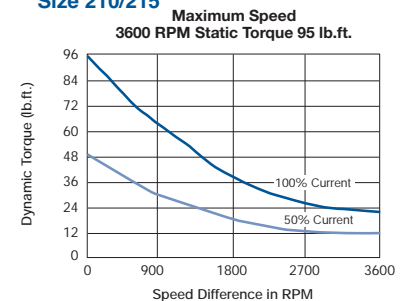

UM Series UniModule

Specifications (Blue shaded areas indicate GEN 2 design)

| UM Size | Static Torque lb. ft. | Maximum RPM | Voltage DC |
|---------|-----------------------|-------------|--------------|
| 50 | 16 | 3600 | 6, 24, or 90 |
| 100 | 30 | 3600 | 6, 24, or 90 |
| 180 | 30 | 3600 | 6, 24, or 90 |
| 210 | 95 | 3600 | 6, 24, or 90 |
| 215 | 95 | 3600 | 6, 24, or 90 |

3. Accessories

Warner Electric UniModules can be fitted with several accessories to extend their capacity and ease of mounting.

a. Conduit Box

NEMA 4 and UL listed, available in standard and washdown versions.

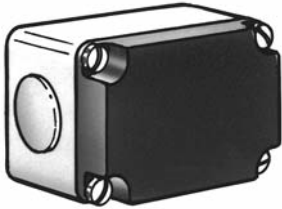

b. Mounting Brackets

Two styles of mounting brackets are available for simplified installation. The base mount is used with the 2030 and 3040 configurations. A motor mount is also available and provides sturdy support for 1020 and 1040 units and a motor.

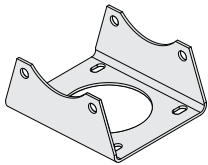

Base Mount

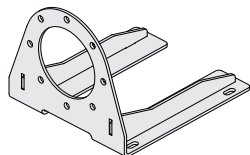

Motor Mount

For 50, 100 & 180 sizes

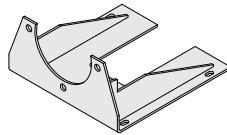

Motor Mount

For 210 & 215 sizes

c. Cover Kit – For sizes 50, 100 & 180



Each cover kit includes two (2) vent covers, two (2) gaskets and four (4) screws needed to convert a vented design into an enclosed design (non-washdown).

4. Select Control

Warner Electric manufactures clutch/brake controls to meet several system functions including:

- On/Off
- Torque adjust
- Over excitation
- Position loop

Many requirements beyond function can impact control selection. See the Controls Section on page 201 for complete information.

| Model No. | | Voltage D.C. | GEN 2 Part No. | Original Part No. |
|--|-------------|--------------|----------------|-------------------|
| UM-1020 w/Pre-installed control | | | | |
| UM50-1020 | w/CBC-150-1 | 90 | 5370-273-230 | 5370-9 |
| UM100-1020 | w/CBC-150-1 | 90 | 5370-273-231 | 5370-10 |
| UM180-1020 | w/CBC-150-1 | 90 | 5370-273-232 | 5370-273-122 |
| UM180-1020 (heavy-duty) | w/CBC-150-1 | 90 | 5370-273-324 | |
| UM210-1020 | w/CBC-150-1 | 90 | | 5371-4 |
| UM215-1020 | w/CBC-150-1 | 90 | | 5371-273-090 |

Ordering Information

Part Numbers

(Blue shaded areas indicate GEN 2 design)

Only 50, 100, and 180 sizes of the models listed will be converted to the new GEN 2 design. 210 and 215 sizes will continue to be offered in the original design and will not be converted.

| Model No. | Voltage D.C. | GEN 2 Part No. | Original Part No. |
|--|--------------|----------------|-------------------|
| 1020 Motor Clutch/Brake | | | |
| UM-50-1020 | 6 | 5370-273-201 | 5370-273-016 |
| UM-50-1020 | 24 | 5370-273-203 | 5370-273-018 |
| UM-50-1020 | 90 | 5370-273-204 | 5370-273-017 |
| UM-100-1020 | 6 | 5370-273-206 | 5370-273-026 |
| UM-100-1020 | 24 | 5370-273-208 | 5370-273-028 |
| UM-100-1020 | 90 | 5370-273-209 | 5370-273-027 |
| UM-180-1020 | 6 | 5370-273-211 | 5370-273-006 |
| UM-180-1020 | 24 | 5370-273-213 | 5370-273-008 |
| UM-180-1020 | 90 | 5370-273-214 | 5370-273-007 |
| UM-210-1020 | 6 | | 5371-273-002 |
| UM-210-1020 | 24 | | 5371-273-004 |
| UM-210-1020 | 90 | | 5371-273-003 |
| UM-215-1020 | 6 | | 5371-273-076 |
| UM-215-1020 | 24 | | 5371-273-077 |
| UM-215-1020 | 90 | | 5371-273-078 |
| Heavy-Duty Models | | | |
| UM-180-1020 | 90 | 5370-273-323 | |
| UM-180-1020* | 90 | 5370-273-324 | |
| 1040 Motor Clutch Output Clutch | | | |
| UM-50-1040 | 6 | 5370-271-201 | 5370-271-004 |
| UM-50-1040 | 24 | 5370-271-203 | 5370-271-006 |
| UM-50-1040 | 90 | 5370-271-204 | 5370-271-005 |
| UM-100-1040 | 6 | 5370-271-206 | 5370-271-024 |
| UM-100-1040 | 24 | 5370-271-208 | 5370-271-026 |
| UM-100-1040 | 90 | 5370-271-209 | 5370-271-025 |
| UM-180-1040 | 6 | 5370-271-211 | 5370-271-014 |
| UM-180-1040 | 24 | 5370-271-213 | 5370-271-016 |
| UM-180-1040 | 90 | 5370-271-214 | 5370-271-015 |
| UM-210-1040 | 6 | | 5371-271-002 |
| UM-210-1040 | 24 | | 5371-271-004 |
| UM-210-1040 | 90 | | 5371-271-003 |
| UM-215-1040 | 6 | | 5371-271-026 |
| UM-215-1040 | 24 | | 5371-271-027 |
| UM-215-1040 | 90 | | 5371-271-028 |
| 2030 Input Clutch/Brake | | | |
| UM-50-2030 | 6 | 5370-273-216 | 5370-273-021 |
| UM-50-2030 | 24 | 5370-273-218 | 5370-273-023 |
| UM-50-2030 | 90 | 5370-273-219 | 5370-273-022 |
| UM-100-2030 | 6 | 5370-273-221 | 5370-273-031 |
| UM-100-2030 | 24 | 5370-273-223 | 5370-273-033 |
| UM-100-2030 | 90 | 5370-273-224 | 5370-273-032 |
| UM-180-2030 | 6 | 5370-273-226 | 5370-273-011 |
| UM-180-2030 | 24 | 5370-273-228 | 5370-273-013 |
| UM-180-2030 | 90 | 5370-273-229 | 5370-273-012 |
| UM-210-2030 | 6 | | 5371-273-007 |
| UM-210-2030 | 24 | | 5371-273-009 |
| UM-210-2030 | 90 | | 5371-273-008 |
| UM-215-2030 | 6 | | 5371-273-043 |
| UM-215-2030 | 24 | | 5371-273-044 |
| UM-215-2030 | 90 | | 5371-273-045 |

* Includes CBC-150-1

| Model No. | Voltage D.C. | GEN 2 Part No. | Original Part No. |
|--|--------------|----------------|-------------------|
| 3040 Input Clutch Output Clutch | | | |
| UM-50-3040 | 6 | 5370-271-216 | 5370-271-009 |
| UM-50-3040 | 24 | 5370-271-218 | 5370-271-011 |
| UM-50-3040 | 90 | 5370-271-219 | 5370-271-010 |
| UM-100-3040 | 6 | 5370-271-221 | 5370-271-029 |
| UM-100-3040 | 24 | 5370-271-223 | 5370-271-031 |
| UM-100-3040 | 90 | 5370-271-224 | 5370-271-030 |
| UM-180-3040 | 6 | 5370-271-226 | 5370-271-019 |
| UM-180-3040 | 24 | 5370-271-228 | 5370-271-021 |
| UM-180-3040 | 90 | 5370-271-229 | 5370-271-020 |
| UM-210-3040 | 6 | | 5371-271-007 |
| UM-210-3040 | 24 | | 5371-271-009 |
| UM-210-3040 | 90 | | 5371-271-008 |
| UM-215-3040 | 6 | | 5371-271-021 |
| UM-215-3040 | 24 | | 5371-271-022 |
| UM-215-3040 | 90 | | 5371-271-023 |

Accessories

| Description | UM Size | Part No. |
|--------------------------------|------------|--------------|
| Conduit Box | All sizes | 5370-101-042 |
| Base Mount Kit for 2030, 3040 | 50/100 | 5370-101-004 |
| | 180 | 5370-101-002 |
| | 210/215 | 5371-101-001 |
| Motor Mount Kit for 1020, 1040 | 50/100 | 5370-101-078 |
| | 180 | 5370-101-079 |
| | 210/215 | 5371-101-012 |
| Cover Kit | 50/100/180 | 5370-101-076 |

How to Order

Motor or Reducer Mounted

Simply combine the size number with the configuration of the required UniModule. Specify voltage. See chart for specific part numbers. Power-off brake UniModules are found on page 106. Order optional conduit box if desired.

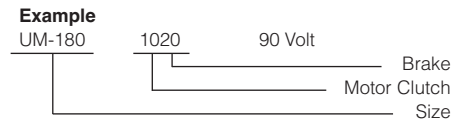

Base Mounted

Simply combine the size number with the configuration of the required UniModule. Specify voltage. See chart for specific part numbers. Power-off brake UniModules are found on page 106. Order optional conduit box if desired.

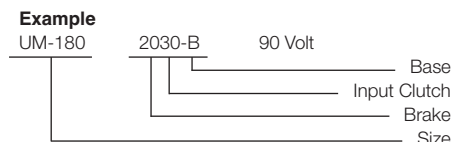

Select Appropriate Power Supply/Control.

UM Series UniModule

UM-1020 Motor Clutch/Brake Combination

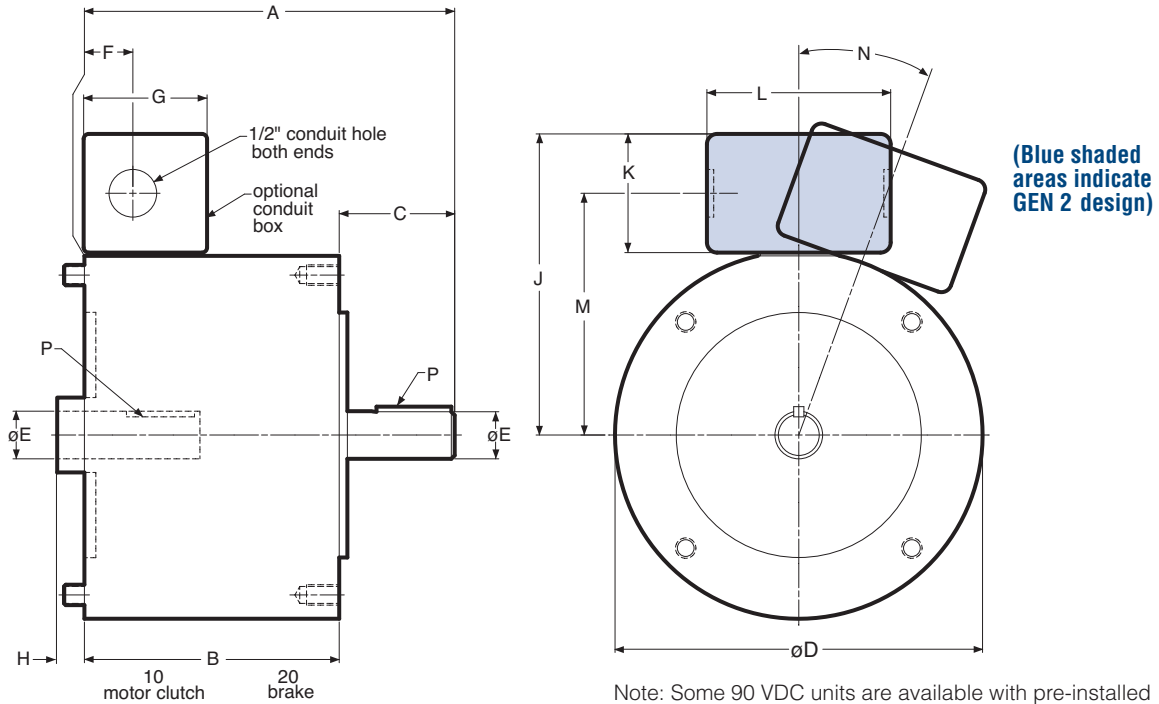

Note: Some 90 VDC units are available with pre-installed controls. On all other modules, conduit box is optional and is ordered separately.

Dimensions (Blue shaded areas indicate GEN 2 design)

| Size | A | B | C | D | E | F | G | H |
|------|-------|-------|-------|-------|-------|------|-------|------|
| 50 | 6.720 | 4.680 | 2.040 | 6.750 | .625 | .890 | 2.267 | — |
| 100 | 6.741 | 4.680 | 2.061 | 6.750 | .625 | .890 | 2.267 | — |
| 180 | 6.801 | 4.680 | 2.121 | 6.750 | .875 | .890 | 2.267 | — |
| 210 | 8.891 | 5.922 | 2.500 | 9.250 | 1.125 | .500 | 2.267 | .500 |
| 215 | 9.391 | 5.922 | 3.000 | 9.250 | 1.375 | .500 | 2.267 | .500 |

| Size | J | K | L | M | N | P |
|------|-------|-------|-------|-------|-----|-------------|
| 50 | 5.516 | 2.180 | 3.250 | 4.426 | 0° | 3/16 x 3/16 |
| 100 | 5.516 | 2.180 | 3.250 | 4.426 | 0° | 3/16 x 3/16 |
| 180 | 5.516 | 2.180 | 3.250 | 4.426 | 0° | 3/16 x 3/16 |
| 210 | 6.859 | 2.180 | 3.250 | 5.766 | 20° | 1/4 x 1/4 |
| 215 | 6.859 | 2.180 | 3.250 | 5.766 | 20° | 5/16 x 5/16 |

Specifications (Blue shaded areas indicate GEN 2 design)

| Model Size | Voltage DC | Static Torque lb. ft. | Max. RPM | NEMA Frame Size |
|------------|------------|-----------------------|----------|--------------------------|
| 50 | 6, 24, 90 | 16 | 3600 | 56C/48Y* |
| 100 | 6, 24, 90 | 30 | 3600 | 56C/48Y** |
| 180 | 6, 24, 90 | 30 | 3600 | 182C/143TC 184C/145TC |
| 210 | 6, 24, 90 | 95 | 3600 | 213C/182TC 215C/184TC |
| 215 | 6, 24, 90 | 95 | 3600 | 213TC/215TC |

* For 56C/48Y Frame motors 3/4 HP and smaller the UM-100 size may be used where extended life is desirable.

** UM-100 size is recommended for motors 1 HP and larger.

For standard NEMA frame dimensions, see page 187.

Only 50, 100, and 180 sizes of the models listed will be converted to the new GEN 2 design. 210 and 215 sizes will continue to be offered in the original design and will not be converted.

UM-1040 Motor Clutch/Output Clutch Combination

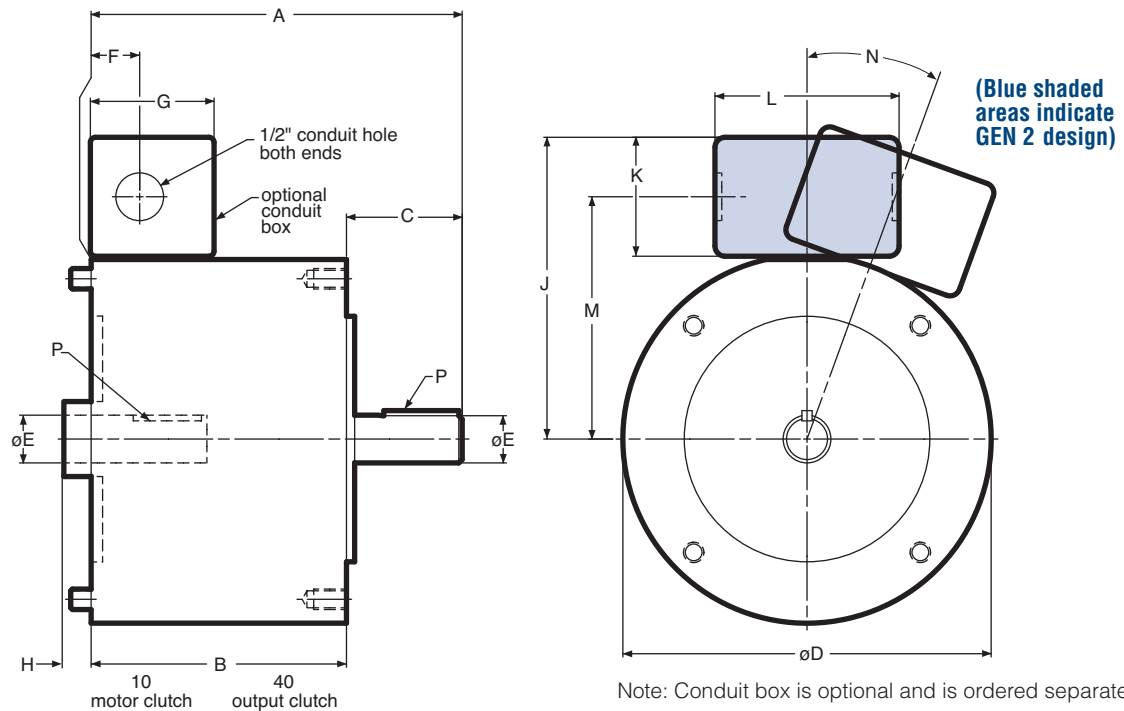

Dimensions (Blue shaded areas indicate GEN 2 design)

| Size | A | B | C | D | E | F | G | H |
|------|-------|-------|-------|-------|-------|------|-------|------|
| 50 | 6.720 | 4.680 | 2.040 | 6.750 | .625 | .890 | 2.267 | — |
| 100 | 6.741 | 4.680 | 2.061 | 6.750 | .625 | .890 | 2.267 | — |
| 180 | 6.801 | 4.680 | 2.121 | 6.750 | .875 | .890 | 2.267 | — |
| 210 | 8.891 | 5.922 | 2.500 | 9.250 | 1.125 | .500 | 2.267 | .500 |
| 215 | 9.391 | 5.922 | 3.000 | 9.250 | 1.375 | .500 | 2.267 | .500 |

| Size | J | K | L | M | N | P |
|------|-------|-------|-------|-------|-----|-------------|
| 50 | 5.516 | 2.180 | 3.250 | 4.426 | 0° | 3/16 x 3/16 |
| 100 | 5.516 | 2.180 | 3.250 | 4.426 | 0° | 3/16 x 3/16 |
| 180 | 5.516 | 2.180 | 3.250 | 4.426 | 0° | 3/16 x 3/16 |
| 210 | 6.859 | 2.180 | 3.250 | 5.766 | 20° | 1/4 x 1/4 |
| 215 | 6.859 | 2.180 | 3.250 | 5.766 | 20° | 5/16 x 5/16 |

Specifications (Blue shaded areas indicate GEN 2 design)

| Model Size | Voltage DC | Static Torque lb. ft. | Max. RPM | NEMA Frame Size |
|------------|------------|-----------------------|----------|--------------------------|
| 50 | 6, 24, 90 | 16 | 3600 | 56C/48Y* |
| 100 | 6, 24, 90 | 30 | 3600 | 56C/48Y** |
| 180 | 6, 24, 90 | 30 | 3600 | 182C/143TC 184C/145TC |
| 210 | 6, 24, 90 | 95 | 3600 | 213C/182TC 215C/184TC |
| 215 | 6, 24, 90 | 95 | 3600 | 213TC/215TC |

* For 56C/48Y Frame motors 3/4 HP and smaller the UM-100 size may be used where extended life is desirable.

** UM-100 size is recommended for motors 1 HP and larger.

For standard NEMA frame dimensions, see page 187.

Only 50, 100, and 180 sizes of the models listed will be converted to the new GEN 2 design. 210 and 215 sizes will continue to be offered in the original design and will not be converted.

UM Series UniModule

UM-2030 Input Clutch/Brake Combination UM-2030-B Input Clutch/Brake Combination – Base Mounted

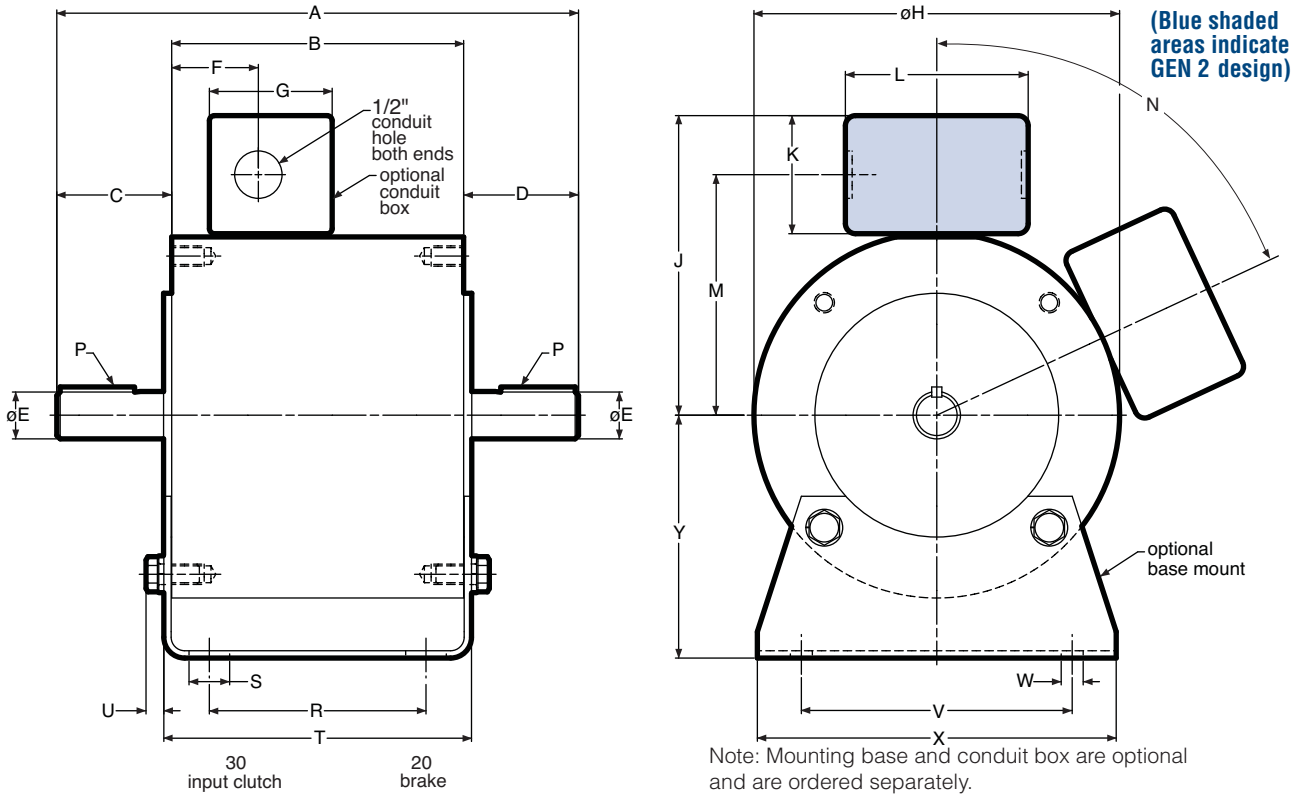

Dimensions (Blue shaded areas indicate GEN 2 design)

| Size | A | B | C | D | E | F | G | H | J | K | L | M |
|------|--------|-------|-------|-------|-------|-------|-------|-------|-------|-------|-------|-------|
| 50 | 9.492 | 5.390 | 2.062 | 2.040 | .625 | 1.600 | 2.267 | 6.750 | 5.516 | 2.180 | 3.250 | 4.426 |
| 100 | 9.512 | 5.390 | 2.061 | 2.061 | .625 | 1.600 | 2.267 | 6.750 | 5.516 | 2.180 | 3.250 | 4.426 |
| 180 | 9.632 | 5.390 | 2.121 | 2.121 | .875 | 1.600 | 2.267 | 6.750 | 5.516 | 2.180 | 3.250 | 4.426 |
| 210 | 12.969 | 7.719 | 2.500 | 2.500 | 1.125 | 1.812 | 2.267 | 9.250 | 6.859 | 2.180 | 3.250 | 5.766 |
| 215 | 12.969 | 7.719 | 2.500 | 2.500 | 1.375 | 1.812 | 2.267 | 9.250 | 6.859 | 2.180 | 3.250 | 5.766 |

| Size | N | P | R | S | T | U | V | W | X | Y |
|------|-----|-------------|-------|------|-------|------|-------|------|-------|-------|
| 50 | 0° | 3/16 x 3/16 | 4.000 | .800 | 5.680 | .329 | 5.000 | .406 | 6.000 | 3.500 |
| 100 | 0° | 3/16 x 3/16 | 4.000 | .800 | 5.680 | .329 | 5.000 | .406 | 6.000 | 3.500 |
| 180 | 0° | 3/16 x 3/16 | 4.000 | .750 | 5.680 | .329 | 5.000 | .406 | 6.625 | 4.500 |
| 210 | 65° | 1/4 x 1/4 | 6.000 | .750 | 8.260 | .437 | 7.750 | .534 | 9.000 | 5.250 |
| 215 | 65° | 5/16 x 5/16 | 6.000 | .750 | 8.260 | .437 | 7.750 | .534 | 9.000 | 5.250 |

Specifications (Blue shaded areas indicate GEN 2 design)

| Model Size | Voltage DC | Static Torque lb. ft. | Max. RPM |
|------------|------------|-----------------------|----------|
| 50 | 6, 24, 90 | 16 | 3600 |
| 100 | 6, 24, 90 | 30 | 3600 |
| 180 | 6, 24, 90 | 30 | 3600 |
| 210 | 6, 24, 90 | 95 | 3600 |
| 215 | 6, 24, 90 | 95 | 3600 |

For standard NEMA frame dimensions, see page 187.

Only 50, 100, and 180 sizes of the models listed will be converted to the new GEN 2 design. 210 and 215 sizes will continue to be offered in the original design and will not be converted.

UM-3040 Input Clutch/Output Clutch Combination UM-3040-B Input Clutch/Output Clutch Combination—Base Mounted

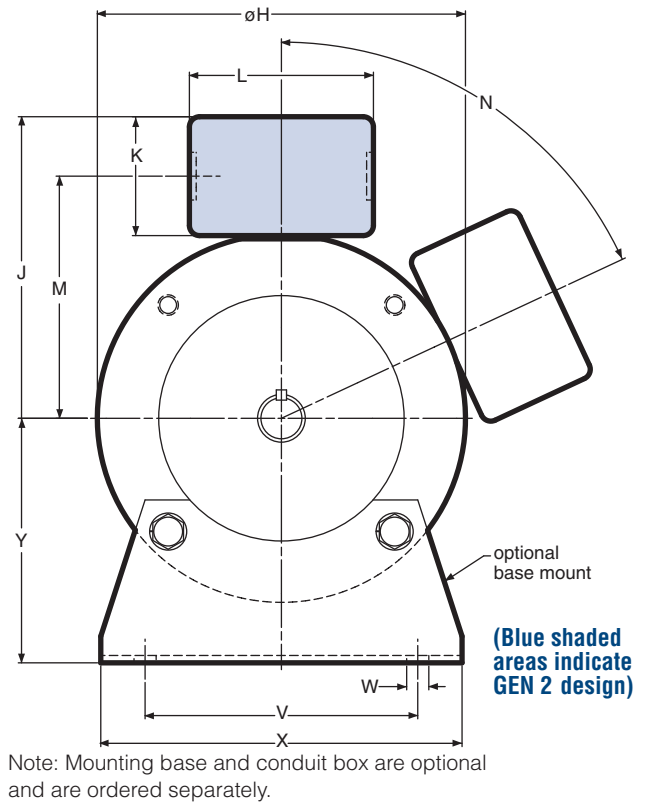
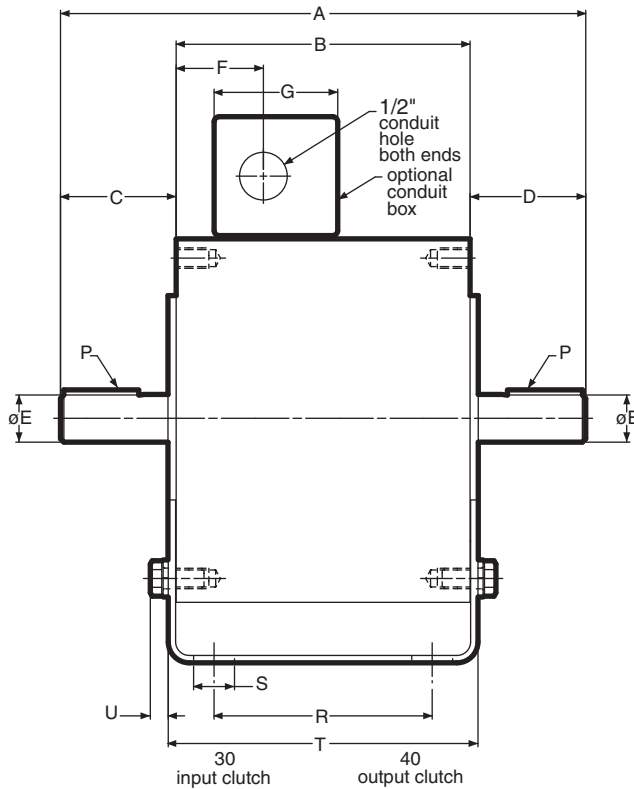

Dimensions (Blue shaded areas indicate GEN 2 design)

| Size | A | B | C | D | E | F | G | H | J | K | L | M |
|------|--------|-------|-------|-------|-------|-------|-------|-------|-------|-------|-------|-------|
| 50 | 9.492 | 5.390 | 2.062 | 2.040 | .625 | 1.600 | 2.267 | 6.750 | 5.516 | 2.180 | 3.250 | 4.426 |
| 100 | 9.512 | 5.390 | 2.061 | 2.061 | .625 | 1.600 | 2.267 | 6.750 | 5.516 | 2.180 | 3.250 | 4.426 |
| 180 | 9.632 | 5.390 | 2.121 | 2.121 | .875 | 1.600 | 2.267 | 6.750 | 5.516 | 2.180 | 3.250 | 4.426 |
| 210 | 12.969 | 7.719 | 2.500 | 2.500 | 1.125 | 1.812 | 2.267 | 9.250 | 6.859 | 2.180 | 3.250 | 5.766 |
| 215 | 12.969 | 7.719 | 2.500 | 2.500 | 1.375 | 1.812 | 2.267 | 9.250 | 6.859 | 2.180 | 3.250 | 5.766 |

| Size | N | P | R | S | T | U | V | W | X | Y |
|------|-----|-------------|-------|------|-------|------|-------|------|-------|-------|
| 50 | 0° | 3/16 x 3/16 | 4.000 | .800 | 5.680 | .329 | 5.000 | .406 | 6.000 | 3.500 |
| 100 | 0° | 3/16 x 3/16 | 4.000 | .800 | 5.680 | .329 | 5.000 | .406 | 6.000 | 3.500 |
| 180 | 0° | 3/16 x 3/16 | 4.000 | .750 | 5.680 | .329 | 5.000 | .406 | 6.625 | 4.500 |
| 210 | 65° | 1/4 x 1/4 | 6.000 | .750 | 8.260 | .437 | 7.750 | .534 | 9.000 | 5.250 |
| 215 | 65° | 5/16 x 5/16 | 6.000 | .750 | 8.260 | .437 | 7.750 | .534 | 9.000 | 5.250 |

Specifications (Blue shaded areas indicate GEN 2 design)

| Model Size | Voltage DC | Static Torque lb. ft. | Max. RPM |
|------------|------------|-----------------------|----------|
| 50 | 6, 24, 90 | 16 | 3600 |
| 100 | 6, 24, 90 | 30 | 3600 |
| 180 | 6, 24, 90 | 30 | 3600 |
| 210 | 6, 24, 90 | 95 | 3600 |
| 215 | 6, 24, 90 | 95 | 3600 |

For standard NEMA frame dimensions, see page 187.

Only 50, 100, and 180 sizes of the models listed will be converted to the new GEN 2 design. 210 and 215 sizes will continue to be offered in the original design and will not be converted.