

# Electric Brakes

## TB Series – Basic Tension Brakes

### System Features

- Full roll to core control
- Consistent tension, even during flying splices, rapid starts and emergency stops
- Eliminates web flutter to allow better registration control
- Electronic System responds in milliseconds
- Dramatically reduces material waste, downtime and maintenance
- Total systems capability—worldwide distribution—local professional service.

### Features – Basic Tension Brakes

- Ideal for light duty, light load unwind tension applications
- Cost effective
- Compact package size
- Eight models
- Small sizes, from 1.7" dia. to 15.25" dia.
- .025 to 1.09 thermal horsepower capacity



### Complete Control Capability

Warner Electric offers two functionally different controls and a companion power supply for all models of TB Series 24 VDC tension brakes. All three units offer compact dimensions and modular design for easy, low cost maintenance. Both controls (MCS-203/MCS-204) and the power supply are furnished with either a panel mount or wall/shelf mount enclosure at no added cost. Controls information starts on page 44.



MCS-203  
Dancer Control



MCS-204  
Remote/Analog  
Control

Unit Size	Energy Rate		Maximum RPM	Minimum <sup>2</sup> Torque (lb.ft.)	Maximum <sup>3</sup> Dynamic Torque (lb.ft.)	Amps	Ohms	Watts
	Continuous	Alternate <sup>1</sup>						
<b>TB-170</b>	0.02 HP	0.03 HP	5000	0.000	0.500	.215	111.2	5.16
<b>TB-260</b>	0.04 HP	0.06 HP	5000	0.060	1.700	.400	60	9.6
<b>TB-425</b>	0.08 HP	0.13 HP	5000	0.120	5.200	.317	76	7.6
<b>TB-500</b>	0.13 HP	0.24 HP	5000	0.150	18.500	1.0	24	24
<b>TB-825</b>	0.27 HP	0.48 HP	3000	0.360	43.200	1.18	20	28
<b>TB-1000</b>	0.48 HP	0.88 HP	2400	0.790	88.000	1.22	20	29
<b>TB-1225</b>	0.70 HP	1.27 HP	2000	1.430	172.000	1.08	22	26
<b>TB-1525</b>	1.09 HP	2.12 HP	1600	2.130	256.000	1.21	20	29

#### Notes

1. Alternate duty operation is defined as 30 minutes run-time with 30 minutes off-time
2. Minimum torque is with Warner Electric tension control providing anti-residual current to brake in off state. Minimum torques will be higher when controls without anti-residual current are used.
3. Dynamic torques are based on 30 RPM slip speed

# Electric Brakes

## TB Series - Basic Tension Brakes

### Dimensions

TB-170

TB-260

TB-425

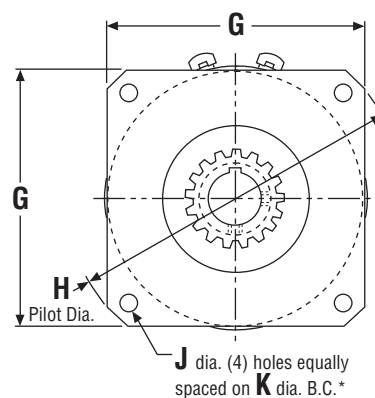
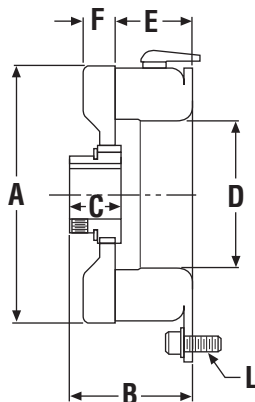

\* Mounting holes are within .010" (.254) of true position relative to pilot diameter.

inches (mm)

Model	A Max.	B Max.	C	D	E	F	G Max.	H	J	K	L
TB-170	1.813 (46.05)	1.203 (30.55)	.404 (10.26)	.750 (19.05)	.812 (20.64)	.281 (7.14)	1.828 (46.43)	2.437/2.435 (61.90/61.85)	.204/.187 (5.18/4.75)	2.125 (53.98)	#8-32 UNC-3A
TB-260	2.719 (69.06)	1.906 (48.42)	.6875 (17.46)	1.375 (34.93)	1.250 (31.75)	.4688 (11.91)	2.641 (67.08)	3.500/3.498 (88.90/88.85)	.204/.187 (5.18/4.75)	3.125 (79.38)	#8-32 UNC-3A
TB-425	4.375 (111.13)	2.047 (51.99)	.875 (22.23)	2.437 (61.91)	1.250 (31.75)	.5625 (14.29)	4.266 (108.36)	5.625/5.623 (142.88/142.82)	.296/.280 (7.52/7.11)	5.000 (12.70)	#1/4-20 UNC-3A

### Bore and Keyway Data

Model No.	Part No.	Voltage	Bore	Keyway	
TB-170	5375-1	6V	1/4"	none	
	5375-4	24V	1/4"	none	
	5375-2	6V	5/16"	none	
	5375-5	24V	5/16"	none	
	5375-3	6V	3/8"	none	
	5375-6	24V	3/8"	none	
TB-260	5365-2	6V	3/8"	3/32" x 3/64"	
	5365-8	24V	3/8"	3/32" x 3/64"	
	5365-3	6V	7/16"	1/8" x 1/16"	
	5365-9	24V	7/16"	1/8" x 1/16"	
	5365-4	6V	1/2"	3/16" x 3/32"	
	5365-10	24V	1/2"	3/16" x 3/32"	
	5365-5	6V	5/8"	3/16" x 3/32"	
	5365-11	24V	5/8"	3/16" x 3/32"	
	5365-6	6V	3/4"	3/16" x 3/32"	
	5365-12	24V	3/4"	3/16" x 3/32"	
	TB-425	5367-5	6V	1/2"	1/8" x 1/16"
		5367-9	24V	1/2"	1/8" x 1/16"
5367-6		6V	5/8"	3/16" x 3/32"	
5367-10		24V	5/8"	3/16" x 3/32"	
5367-7		6V	3/4"	3/16" x 3/32"	
5367-11		24V	3/4"	3/16" x 3/32"	
5367-8		6V	7/8"	3/16" x 3/32"	
5367-12		24V	7/8"	3/16" x 3/32"	

Model No.	Part No.	Voltage	Bushing	Bore	Keyway
TB-500	5310-2	6V	Dodge 1215	1/2-9/16	1/8" x 1/16"
	5310-24	24V	(see pg 155 for for specific P/N)	5/8-7/8 15/16-1-1/4	3/16" x 3/32" 1/4" x 1/8"

### Dimensions

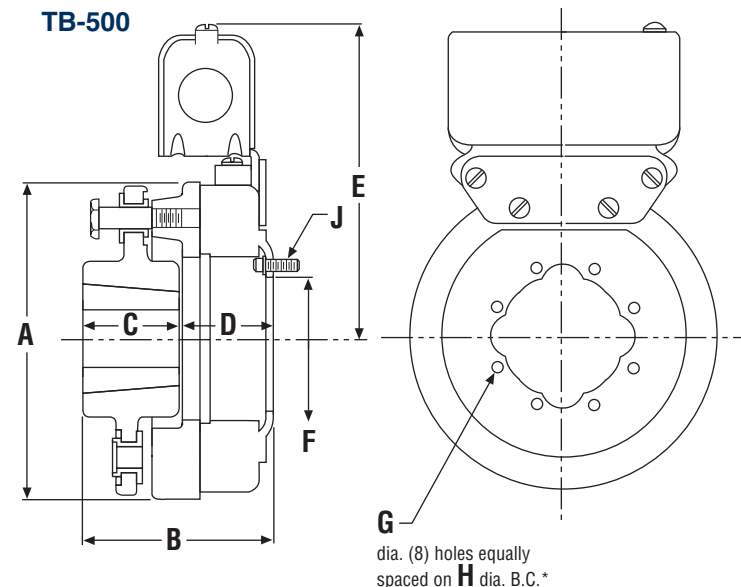

\* Mounting holes are within .010" (.254) of true position relative to pilot diameter.

inches (mm)

Model	A Max.	B Max.	C	D	E Max.	F	G	H	J
TB-500	5.125 (130.18)	3.140 (79.77)	1.500 (38.10)	1.594 (40.48)	5.062 (128.59)	2.062 (52.39)	.208/.201 (5.28/5.11)	2.375 (60.33)	#8-32 UNC-3A

For replacement parts list and exploded view drawing, see page 76.

**Note:** All dimensions are nominal unless otherwise noted.

# Electric Brakes

## TB Series – Basic Tension Brakes

### Dimensions

TB-825

TB-1000

TB-1225

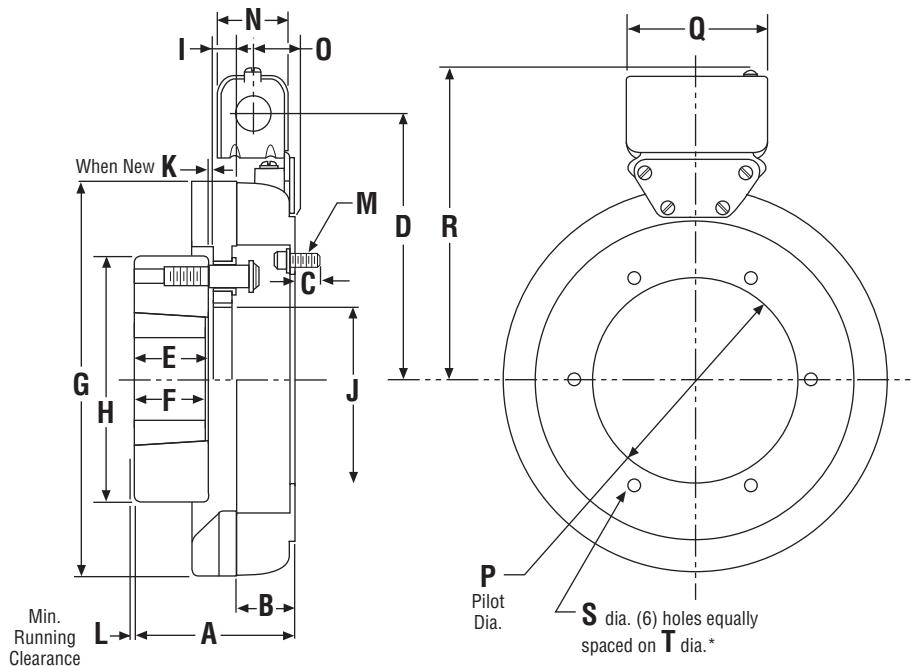

\* Mounting holes are within .010" (.254) of true position relative to pilot diameter.

inches (mm)

Model	A Max.	B	C Max.	D	E	F	G Max.	H Dia.	I	J Dia.
TB-825	3.671 (93.24)	1.312 (33.32)	.562 (14.27)	5.656 (143.66)	1.593 (40.146)	1.500 (38.10)	8.468 (215.09)	4.625 (117.48)	.609 (15.47)	2.187 (55.55)
TB-1000	4.109 (104.37)	1.453 (36.91)	.562 (14.27)	6.531 (165.89)	1.906 (48.41)	1.750 (44.45)	10.187 (258.75)	6.250 (158.75)	.609 (15.47)	3.875 (94.83)
TB-1225	5.390 (136.91)	1.6740 (41.66)	.562 (14.27)	7.531 (191.29)	3.000 (76.20)	3.000 (76.20)	12.437 (315.90)	6.875 (174.63)	.609 (15.47)	4.500 (114.30)

Model	K Min.	L	M	N	O	P Max.	Q	R	S	T
TB-825	.093 (2.36)	.062 (12.57)	5/16-18 UNC-3A	1.546 (39.27)	.921 (23.39)	3.503/3.501 (88.98/88.93)	3.750 (95.25)	6.406 (162.71)	.358/.338 (9.09/8.59)	4.250 (107.95)
TB-1000	.093 (2.36)	.062 (1.57)	5/16-18 UNC-3A	1.546 (39.27)	.921 (23.39)	5.378/5.376 (136.60/136.55)	3.750 (95.25)	7.687 (195.25)	.358/.338 (9.09/8.59)	6.125 (155.58)
TB-1225	.093 (2.36)	.062 (1.57)	5/16-18 UNC-3A	1.546 (39.27)	.921 (23.39)	6.378/6.376 (162.00/161.95)	3.750 (95.25)	8.687 (220.65)	.358/.338 (9.09/8.59)	7.250 (184.15)

See page 155 for specific bushing part numbers.

### Bore and Keyway Data

Model #	Part #	Voltage	Bushing	Bore	Keyway
TB-825	5311-2	6V	Dodge 1615	1/2-9/16	1/8" x 1/16"
	5311-24	24V	(see pg 159 for specific P/N)	5/8-7/8	3/16" x 3/32"
				15/16-1-1/4	1/4" x 1/8"
				1-5/16-1-3/8	5/16" x 5/32"
				1-7/16-1-1/2	3/8" x 3/16"
TB-1000	5312-1	6V	Dodge 2517	1/2-9/16	1/8" x 1/16"
	5312-24	24V	(see pg 159 for specific P/N)	5/8-7/8	3/16" x 3/32"
				15/16-1-1/4	1/4" x 1/8"
				1-5/16-1-3/8	5/16" x 5/32"
				1-7/16-1-3/4	3/8" x 3/16"

Model #	Part #	Voltage	Bushing	Bore	Keyway
TB-1225	5313-1	6V	Dodge 3030	15/16-1-1/4	1/4" x 1/8"
	5313-24	24V	(see pg 155 for specific P/N)	1-5/16-1-3/8	5/16" x 5/32"
				1-7/16-1-3/4	3/8" x 3/16"
				1-13/16-2-1/4	1/2" x 1/4"
				2-5/16-2-3/4	5/8" x 5/16"
TB-1525	5314-1	6V	Dodge 3030	15/16-1-1/4	1/4" x 1/8"
	5314-24	24V	(see pg 155 for specific P/N)	1-5/16-1-3/8	5/16" x 5/32"
				1-7/16-1-3/4	3/8" x 3/16"
				1-13/16-2-1/4	1/2" x 1/4"
				2-5/16-2-3/4	5/8" x 5/16"

For replacement parts list and exploded view drawing, see page 77.

**Note:** All dimensions are nominal unless otherwise noted.

### Dimensions

#### TB-1525

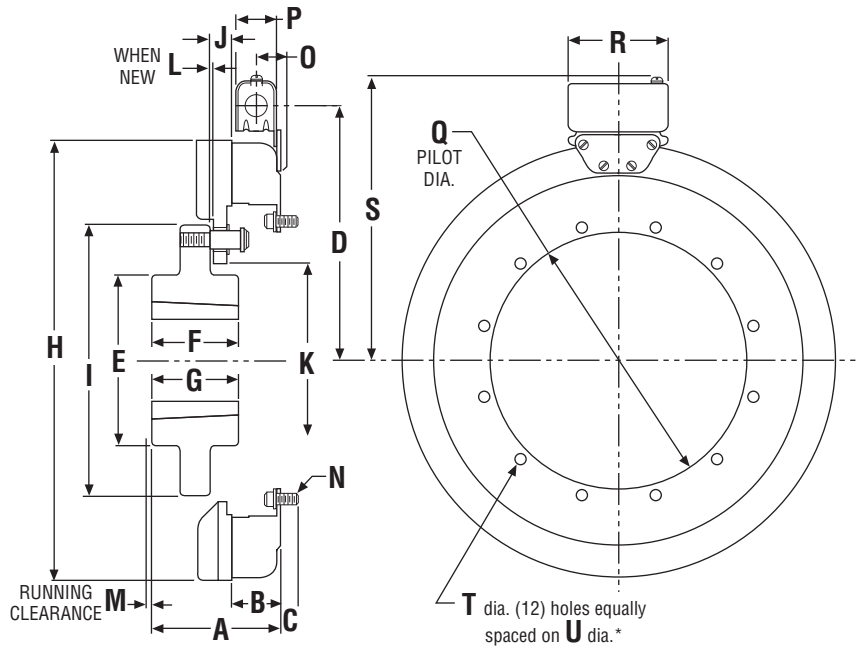

inches (mm)

\* Mounting holes are within .010" (.254) of true position relative to pilot diameter.

Model	A Max.	B	C Max.	D	E Dia.	F	G	H Dia.	I Dia.	J Dia.	K Dia.
TB-1525	4.531 (115.09)	1.750 (44.45)	.562 (14.27)	9.187 (233.35)	6.000 (152.40)	3.000 (76.2)	3.000 (76.2)	15.562 (395.27)	9.500 (241.30)	.609 (15.47)	7.125 (180.98)

Model	L	M Min.	N	O	P Max.	Q	R	S	T	U
TB-1525	.093 (2.36)	.062 (1.57)	5/16-18 UNC-3A	.921 (23.39)	1.546 (39.27)	9.002/9.000 (228.65/228.60)	3.750 (95.25)	10.343 (262.71)	.358/.338 (9.09/8.59)	9.750 (247.65)

See page 155 for specific bushing part numbers.

For replacement parts list and exploded view drawing, see page 77.

**Note:** All dimensions are nominal unless otherwise noted.

# Brake Assemblies and Part Numbers

## TB Series – Basic Tension Brakes

### TB-170, TB-260, TB-425

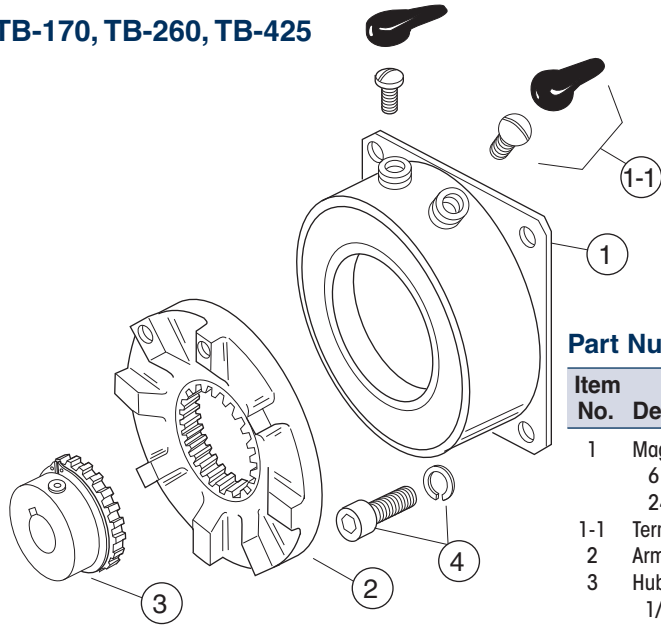

#### Part Numbers

Item No.	Description	TB-170		TB-260		TB-425	
		Qty.	P/N	Qty.	P/N	Qty.	P/N
1	Magnet, O.M.	1		1		1	
	6 Volt		5375-631-010		5365-631-013		5367-631-007
	24 Volt		5375-631-012		5365-631-016		5367-631-008
1-1	Terminal Accessory		—	1	5103-101-002	1	5103-101-003
2	Armature	1	110-0096	1	110-0097	1	110-0098
3	Hub Assembly	1		1		1	
	1/4" Bore		5102-541-002		—		—
	5/16" Bore		5102-541-003		—		—
	3/8" Bore		5102-541-004		5103-541-002		—
	1/2" Bore		—		5103-541-004		5104-541-002
	5/8" Bore		—		5103-541-006		5104-541-004
	3/4" Bore		—		5103-541-008		5104-541-006
	7/8" Bore		—		—		5104-541-007
4	Mounting Accessories	1	5102-101-001	1	5102-101-001	1	5104-101-002

### TB-500

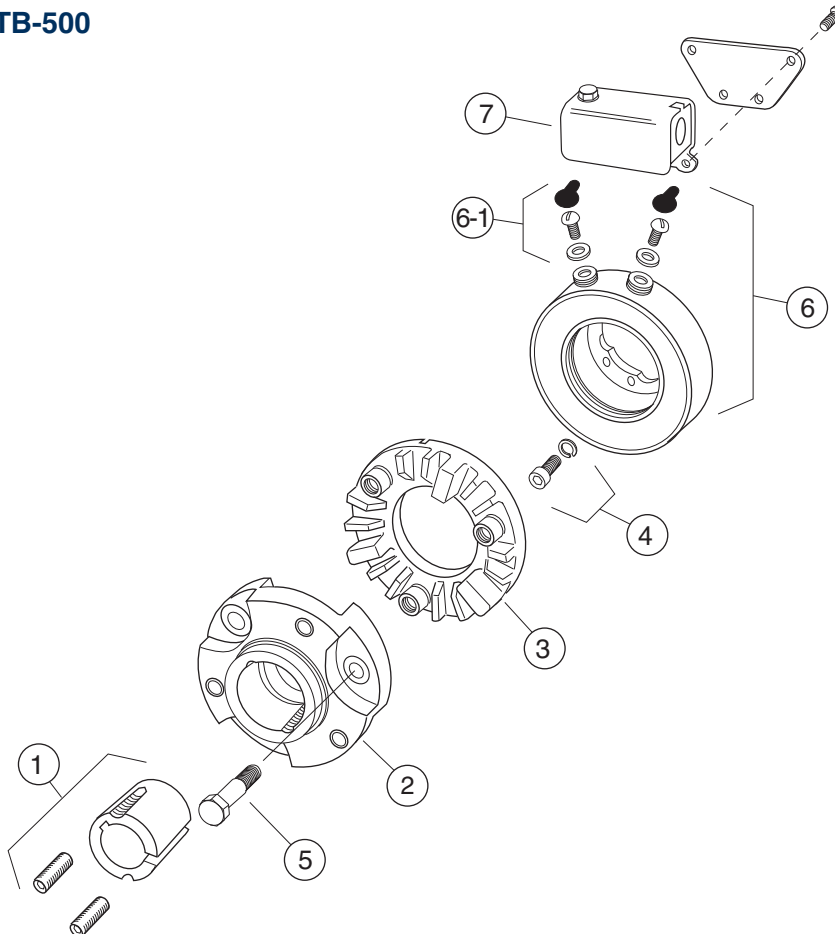

#### Part Numbers

Item No.	Description	TB-500	
		Qty.	P/N
1	Bushing Taperlock*	1	180-0116 to 180-0128
2	Hub, Armature	1	5300-541-004
3	Armature	1	110-0047
4	Magnet Mounting Acc.		
	Inside Mounted	2	5102-101-001
	Outside Mounted	1	5300-101-008
5	Drive Pin	3	5300-101-003
6	Magnet		
	6 Volt I.M.	1	5300-631-019
	6 Volt O.M.	1	5300-631-024
	24 Volt I.M.	1	5300-631-040
	24 Volt O.M.	1	5300-631-051
6-1	Terminal Accessory	1	5311-101-001
7	Conduit Box	1	5200-101-010

\* See page 155 for specific shaft sizes and bushing numbers.

# Brake Assemblies and Part Numbers

TB Series – Basic Tension Brakes

TB-825, TB-1000, TB-1225, TB-1525

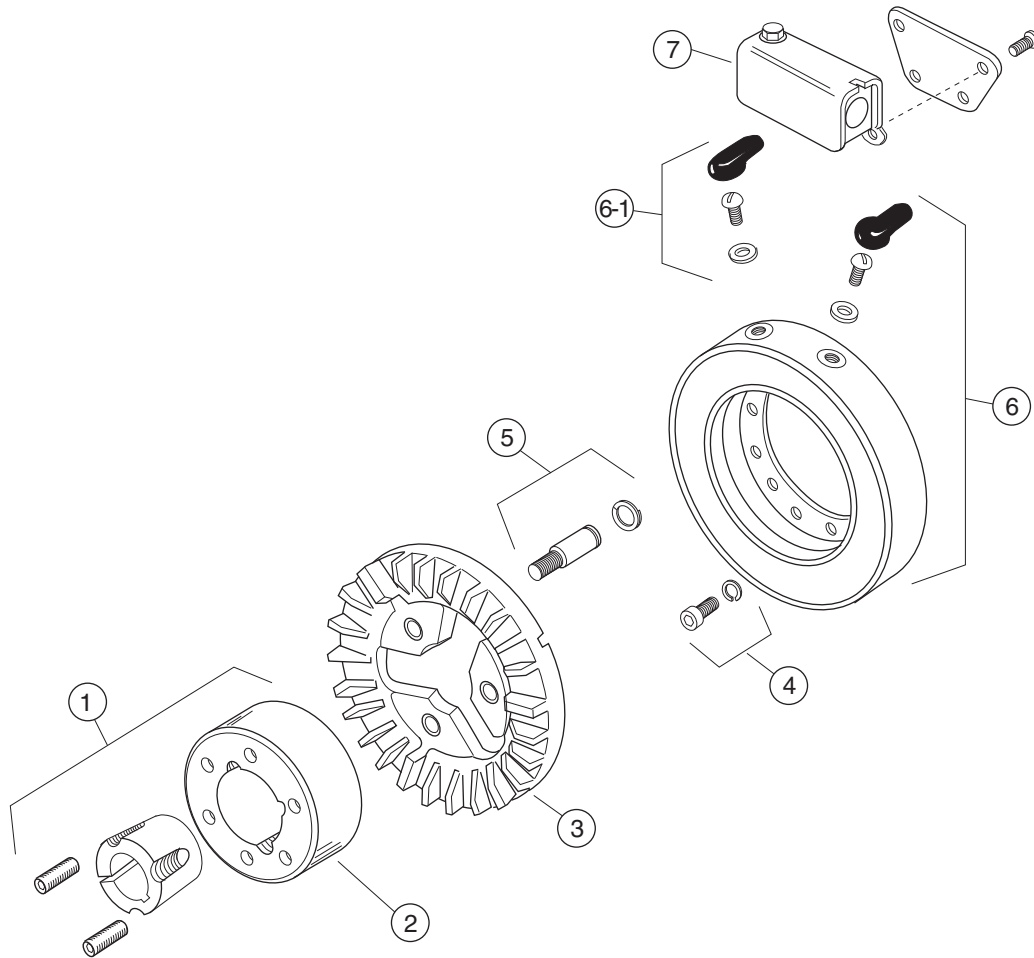

## Part Numbers

Item No.	Description	Qty.	TB-825		TB-1000		TB-1225		TB-1525	
			P/N	Qty.	P/N	Qty.	P/N	Qty.	P/N	
1	Bushing Taperlock*	1	180-0131 to 180-0149	1	180-0185 to 180-0217	1	180-0262 to 180-0295	1	180-0262 to 180-0295	
2	Hub, Armature	1	540-0394	1	540-0313	1	540-0015	1	540-0314	
3	Armature	1	5301-111-019	1	5302-111-021	1	5303-111-011	1	5304-111-005	
4	Magnet Mounting Acc.									
	Inside Mounting	1	5321-101-001	1	5321-101-001	1	5321-101-001	2	5321-101-001	
5	Drive Pin & Retainer	3	5301-101-001	3	5301-101-001	4	5301-101-001	4	5301-101-001	
6	Magnet	1		1		1		1		
	6 Volt I.M.		5311-631-024		5312-631-018		5313-631-017		5314-631-002	
	24 Volt I.M.		5311-631-040		5312-631-034		5313-631-031		5314-631-022	
6-1	Terminal Accessory	1	5311-101-001	1	5311-101-001	1	5311-101-001	1	5311-101-001	
7	Conduit Box	1	5200-101-011	1	5200-101-011	1	5200-101-011	1	5200-101-011	

\* See page 155 for specific shaft sizes and bushing numbers.

These units, when used with the correct Warner Electric conduit box, meet the standards of UL-508 and are listed under the guide card #NMTR, file #59164 and are CSA Certified under file #LR11543.