

CB Series and Super CB Series Sizes 2, 4, 5, 6 and 8

P-258
819-0406

Troubleshooting Guide



An Altra Industrial Motion Company

Contents

Introduction and Features	2
Mounting and Installation Notes	3
Stop Collar Adjustment	5
Lubrication	6
Troubleshooting the Actuator	6
Troubleshooting the Clutch/Brake	8
Spring Differential Adjustment	11
Dust Covers	13
Warranty	back cover

1. Introduction

Warner Electric's CB and Super CB Wrap Spring products incorporate all the necessary components to accurately start and stop a load driven by a continuously rotating input. Each unit has been engineered to be a preassembled package, consisting of a clutch and a brake with a stop collar and solenoid actuator affixed to a backing plate. Both the CB and Super CB are capable of locking the load in both directions so no external anti-back or overtravel mechanism is required to maintain registration.

⚠ WARNING Failure to follow these instructions may result in product damage, equipment damage, and serious or fatal injury to personnel.

Features

- Starts and stops within $\pm 1/2^\circ$ in a 360° revolution, with no cumulative error
- Preassembled, packaged product
- May be cycled or run continuously
- Operates on a single AC or DC pulse
- Maximum operating speeds from 300 to 1,800 RPM
- Maximum torque ratings from 25 to 2,500 lb. in.
- Incrementally adjustable collar for positioning output
- Sintered metal, oil impregnated components provide permanent lubrication, and long life

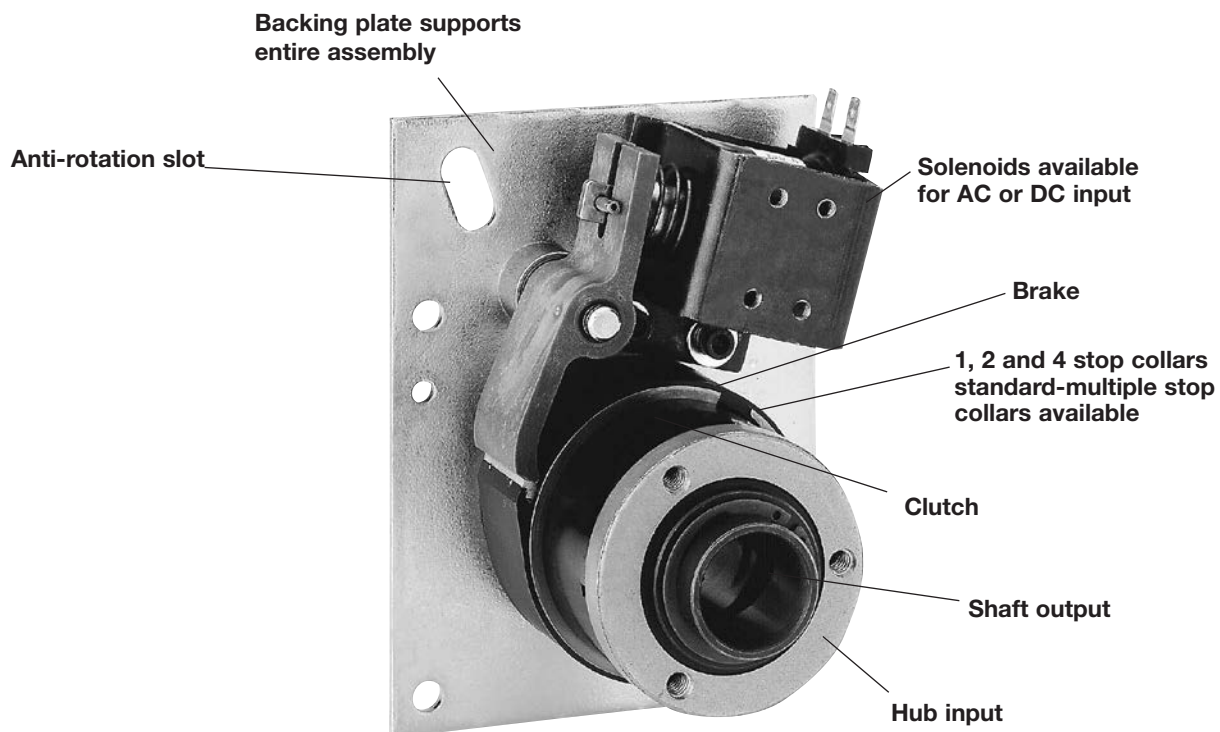

2. Mounting and Installation

Warner Electric wrap spring clutches and clutch/brakes are factory assembled, requiring no adjustments during installation.

Each clutch/brake backing plate assembly has three or four mounting holes plus an anti-rotation slot, and is designed to serve as a torque arm rather than as a rigid mounting plate. The plate should be restrained from rotating by a pin or shoulder bolt, while allowing it to float axially. The anti-rotation device must be capable of withstanding the braking torque required by the load.

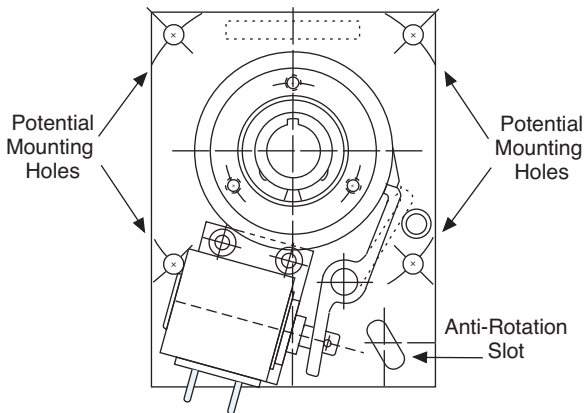

Clockwise Rotation Shown

Important: Do not rigidly mount unit. Plate must be allowed to “float” axially.

All Warner Electric wrap spring products are designed to be installed in parallel shaft applications where they are fully supported by the shaft on which they are mounted. Connecting the unit to the parallel shaft may be accomplished by pinning (for sizes 2, 4, and 5) or by key and set screw (for sizes 6 and 8).

When connecting the parallel shaft to the CB by using a belt, chain, or gear drive, the input hub’s radial bearing load capacity must not be exceeded (see following chart). It may be necessary to counter bore or bearing mount the input pulley sprocket or gear.

Maximum Radial Bearing Load at Maximum Speed

- CB-2 = 7.5 lbs.
- CB-4 = 14 lbs.
- CB-5/Super CB-5 = 32 lbs.
- CB-6/Super CB-6 = 63 lbs.
- CB-8/Super CB-8 = 300 lbs.

CB and Super CB style clutch/brakes are designed for horizontal shaft mounting. Therefore, horizontal mounting is the preferred method. While it is possible to mount units vertically, vertically mounted units will see lower life than those mounted horizontally due to the wear between hubs resulting from gravity.

Input hub thread engagement requirements.

Just a reminder. . .While mounting a sprocket or pulley to the input hub of your CB-2, CB-4, CB-5, CB-6, or CB-8, the screws/bolts used must not protrude through the flange or hub. This will interfere or jam the control collar assembly, thereby causing the clutch to malfunction by failing to “drive” or causing the clutch to “slip.”

Maximum Thread Engagement

- CB-2 = .150 in.
- CB-4 = .280 in.
- CB-5/Super CB-5 = .350 in.
- CB-6/Super CB-6 = .312 in.
- CB-8/Super CB-8 = .360 in.

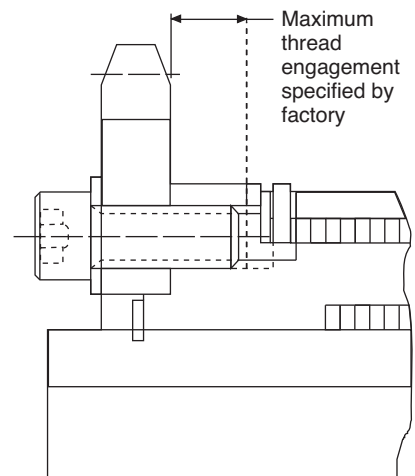

Correct Thread Engagement

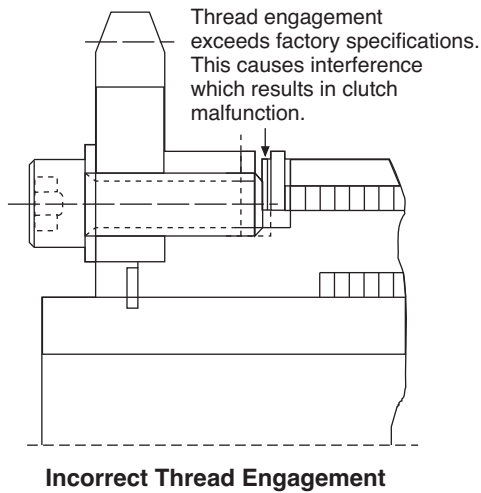

Horizontal Mounting

Figure 1 illustrates an ideal clutch/brake mounting application. The unit is attached to the output shaft with both a key and set screws. The plate is restrained from rotating, but not from axial movement, reducing the side load on the CB's internal plate bearing.

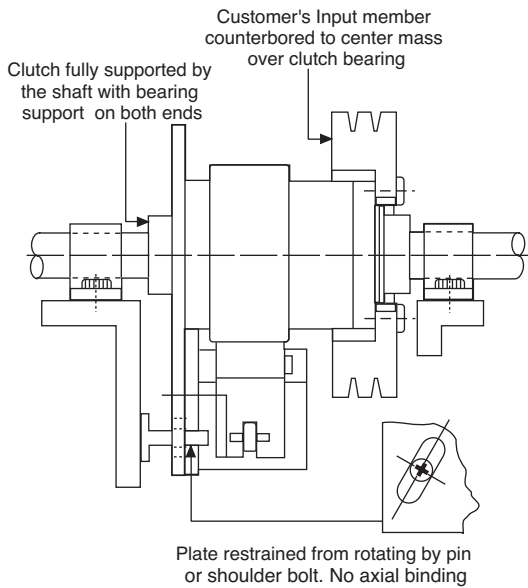

Figure 1 - Ideal Mounting

In cases where easy access to the input is desirable, the clutch/brake can be mounted on a stub shaft. However, the unit must still be fully supported, while overhung loads on the input member must be avoided to maintain the life of the radial bearing.

Figures 2 and 3 illustrate alternate mounting configurations for achieving proper support. Inputs are usually face-mounted to the input hub of the CB unit as shown in Figure 1. This type of mounting is facilitated by the drilled and tapped holes provided in the free hub flange. The configuration shown in Figure 2 is a possibility, if the radial load on the input hub of the CB is small compared to the specified load.

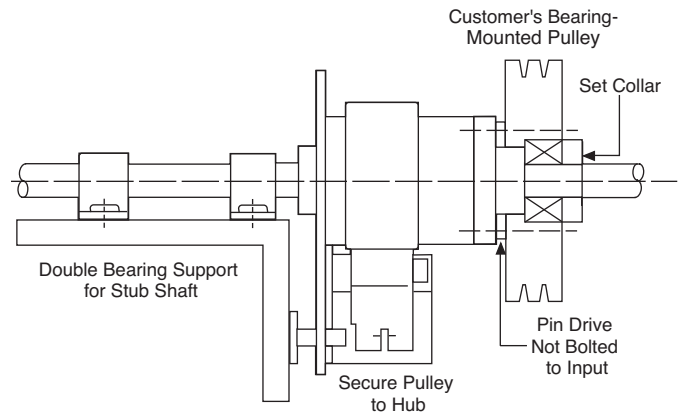

Figure 2 – Acceptable Mounting

If the application contains a substantial radial bearing load, arrange the pulley over the centerline of the clutch free hub as illustrated in Figure 3. Place one support bearing as close to the pulley as possible, using a torque arm for anti-rotation.

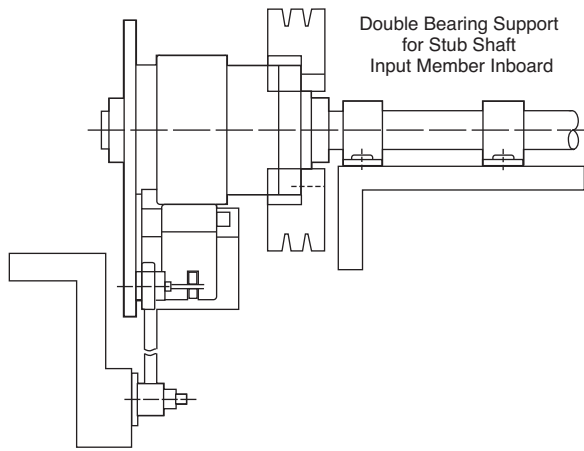

Figure 3 – Acceptable Mounting

The smaller CB units (sizes 2, 4 and 5) have pilot holes in the output shaft, which guide drilling through the machine shaft for attaching the unit with a pin.

Vertical Mounting

When it is necessary to mount a unit vertically, mount it so the input hub is oriented in the upward position as illustrated in Figure 4.

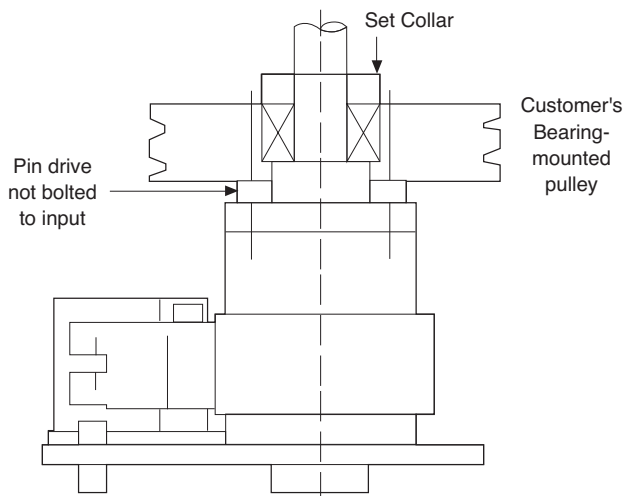
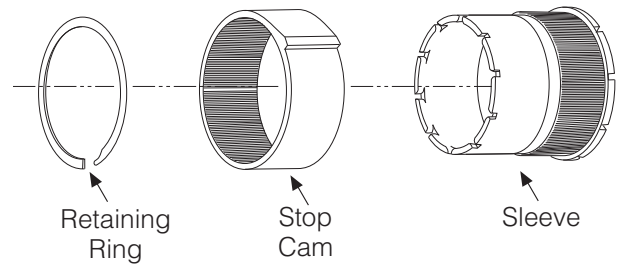

Figure 4

Stop Collar Adjustment

Each CB Series unit has an incrementally adjustable collar, allowing for changes to the output orientation.



To adjust the stop collar output orientation:

1. Remove the retaining ring from its groove and slide it forward on the sleeve.
2. Hold the actuator clear while sliding the cam off the sleeve. Rotate the cam to the desired stop position, and slide it back onto the sleeve. (The brake should be fully wrapped down to ensure setting the proper stop point).

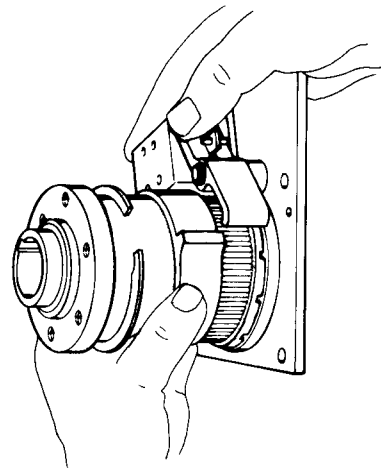

Note: Simply rotating the input hub until the actuator hits the cam will not fully wrap down the brake spring.

Wrapping the brake spring down completely can be accomplished by rotating the output shaft in driving direction until it cannot travel any further.

3. Slide the retaining ring back into position.

Adjustment Increments with Standard Stop Collars:

CB-2	Infinitely Adjustable
CB-4	2.4° Adjustable
CB-5/Super CB-5	1.8° Adjustable
CB-6/Super CB-6	1.8° Adjustable
CB-8/Super CB-8	1.6° Adjustable

Lubrication

All CB Series clutch/brakes are manufactured with oil impregnated, sintered metal components. A properly applied and installed Warner Electric wrap spring clutch/brake requires no lubrication throughout the life of the unit. Adding lubrication may result in a mis-match of lubricants which may lead to premature spring failure.

3. Troubleshooting the Actuator

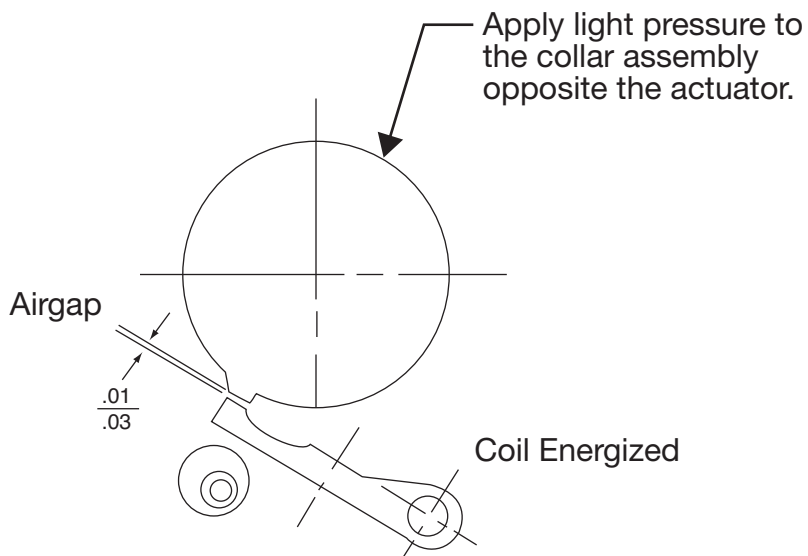

Figure 5

Troubleshooting Checklist

The actuator is simply a mechanical linkage. When the actuator does not function, the following inspection should be made.

Possible Problem	Recommended Action
1. No power going to the coil (check w/voltmeter).	<p>A. Check all wiring and switching in the system that supplies power to the clutch coil, and ensure its continuity.</p> <p>B. If wiring is correct, inspect to see if power is coming from the power supply. If there is no power from the power supply, check switching or programming and/or replace power supply as necessary.</p>
2. Lack of continuity in coil windings (check w/ohmmeter).	Check the continuity of the clutch coil windings by using an ohmmeter, and replace the coil if necessary. After the coil is replaced, ensure it is properly aligned as described in Step 3A below.
3. Mechanical binding of plunger.	<p>A. Realign coil. As shown in Figure 5, with the coil energized, apply light pressure to the opposite side of the control collar, and set the actuator/cam tip clearance (airgap) at .010" to .030". Note: For AC coils with an actuator limit stop (ALS) option, the actuator should hit the ALS and bottom simultaneously.</p> <p>B. If Step 3A fails to resolve the problem, replace the coil assembly and perform Step 3A again to realign the coil.</p>
4. Actuator does not clear the cam stop	Realign coil as in Step 3A above.
5. Collar pushes so hard on the actuator that the coil is unable to pull in.	<p>A. Actuator loading can be caused by the braking force exceeding the capacity of the brake spring. Confirm the application criteria and re-evaluate the unit size for this application.</p> <p>B. If the spring differential setting is too large, the clutch spring could be opening into the control collar and acting as a brake. In this case, the spring differential must be reset (See Section 5 "CB Spring Differential Adjustment").</p> <p>C. If the coil has been replaced with an air cylinder, ensure that the cylinder is square to the collar and that the actuator has the proper travel. Inspect the air source and supply to ensure the cylinder is receiving air when appropriate.</p>

4. Troubleshooting the Clutch/Brake Unit

When the brake spring is engaged, i.e., fully wrapped down, the input should be free to rotate by hand. Wrapping the brake spring down completely can be accomplished by rotating the output shaft in the driving direction until it cannot travel any further. Please note that units with anti-overrun springs (most units) will allow the input hub to turn only in the direction of rotation.

Troubleshooting Checklist

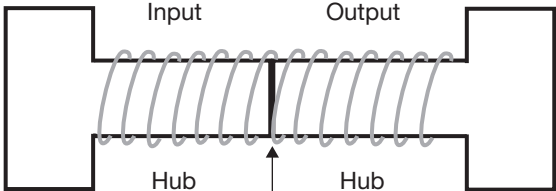
Possible Problem	Recommended Action
<p>1. Continuous driving (input and output hubs locked together - unit continues to drive even with collar blocked)</p>  <p style="text-align: center;">Crossover point is where the spring crosses over from one hub to the other.</p> <p style="text-align: center;">Figure 6</p>	<p>A. The spring differential setting is too small. Reset differential (see Section 5 “CB Spring Differential Adjustment”).</p> <p>B. The endplay (axial clearance between hubs) setting is too close. Reset the endplay by moving the output sleeve on the shaft until a minimum of .003" to .006" clearance is achieved. CAUTION: Use a brass hammer to avoid shaft damage.</p> <p>C. The hubs are necked down (worn at the spring crossover point) and the spring is caught between the two hubs and cannot release. This could be a result of excess torque being applied to the unit. Re-evaluate sizing. Replace unit or rebuild with “Heavy Repair Kit” and then reset endplay.</p> <p>Note: On Rebuilding Units: As a general rule, when springs are replaced, the hubs should be as well. Given that the springs and hubs are the majority of the cost of the unit, it is often not economically feasible to rebuild units when replacement of the springs and hubs is required.</p> <p>D. The bearing surface between the input and output hubs is galled and the unit should be replaced. If galling was caused by contaminants, add a dust cover to reduce contamination (See Section 6). If galling was caused by excessive radial side loading or an overhung load, correct this condition by mounting the input member properly (See Section 2).</p>
<p>2. Input is free, but the clutch won’t engage when actuated.</p>	<p>A. The spring differential setting is too loose. Reset the differential (see Section 5 “CB Spring Differential Adjustment”).</p> <p>B. Check the clutch spring for damage. Replace as necessary with “Light Repair Kit.”</p> <p>C. The control collar cannot move because foreign matter is blocking it. Clean the unit and add a dust cover to reduce contamination (See Section 6).</p> <p>D. The actuator/cam tip clearance is inadequate. Reset the airgap by realigning the coil (See Section 3, Step 3A).</p> <p>E. The coil has failed. Replace coil and realign to set airgap. (See Section 3, Step 3A).</p>
<p>3. Clutch/Brake stalls motor when engaged.</p>	<p>A. See solutions to Problem 1, “Continuous driving.”</p>
<p>4. Control collar tang slot ripped out.</p>	<p>A. The spring differential setting was incorrect or altered. Replace the collar and reset the spring differential (See Section 5).</p> <p>B. Unit was rotated in reverse direction. Replace broken parts with “Light Repair Kit.” Do not reverse unit.</p> <p>C. The torque or inertia of the application is too large for the unit. Re-evaluate unit size.</p>

Troubleshooting Checklist (continued)

Possible Problem	Recommended Action																								
<p>5. Lubrication has been added to the unit. Added lubrication can result in a mis-match of lubricants which can cause a soapy appearing viscous material around the collar and springs. This can cause the springs to slide on the hubs rather than grab them. The result is a loss of accuracy.</p>	<p>A. Disassemble the unit. Using a clean rag, wipe excess material from the hubs, springs and collar. Do not use solvent. (If the added lubricant was due to spray from a chain lubricator, take steps to guard against reoccurrence.) When re-assembling the unit ensure that the spring differential is set properly. See Section 5 "CB Spring Differential Adjustment."</p>																								
<p>6. Output does not repeat stopping point</p> <table border="1" data-bbox="139 781 766 1066"> <thead> <tr> <th>Clutch</th> <th>T_c</th> <th>t</th> <th>I_c</th> </tr> </thead> <tbody> <tr> <td>CB-2</td> <td>1.65</td> <td>0.003</td> <td>0.0116</td> </tr> <tr> <td>CB-4</td> <td>4.40</td> <td>0.004</td> <td>0.0450</td> </tr> <tr> <td>CB-5</td> <td>6.88</td> <td>0.004</td> <td>0.1663</td> </tr> <tr> <td>CB-6</td> <td>8.75</td> <td>0.005</td> <td>1.221 (0.75 in. bore) 1.138 (1.0 in. bore)</td> </tr> <tr> <td>CB-8</td> <td>20</td> <td>0.005</td> <td>9.43 (.075 in. bore) 9.32 (1.0 in. bore) 8.15 (1.5 in. bore)</td> </tr> </tbody> </table> $I = (t) \frac{(T_c + T_o)}{\text{RPM}} (3700) - I_c$ <p>How to determine maximum inertia load.</p> $\frac{T \times 3700 \times t}{\text{RPM}} = WR^2$	Clutch	T _c	t	I _c	CB-2	1.65	0.003	0.0116	CB-4	4.40	0.004	0.0450	CB-5	6.88	0.004	0.1663	CB-6	8.75	0.005	1.221 (0.75 in. bore) 1.138 (1.0 in. bore)	CB-8	20	0.005	9.43 (.075 in. bore) 9.32 (1.0 in. bore) 8.15 (1.5 in. bore)	<p>A. There is not enough RPM or inertia to fully disengage the clutch spring and fully engage the brake spring. Add inertia by either increasing RPM or adding weight to the output (such as a sprocket or flywheel). To calculate the inertia required, use the following table and formula:</p> <p>Minimum Inertia Calculation</p> <p>I = Minimum inertia required to fully activate the Clutch/Brake - lb.in.²</p> <p>t = Time – Seconds</p> <p>T_c= Torque required to fully activate the Clutch/Brake – in.lb.</p> <p>T_o= Frictional Torque – in.lb.</p> <p>RPM = Revolutions per minute</p> <p>I_c = Inertia at the output side of the clutch – lb. in.²</p> <p>Example: CB-5 in a system running at 300 RPM with 10 in. lb. drag. What inertia is required to fully activate the Clutch/Brake?</p> $I = \frac{(0.004) (6.88 + 10) (3700)}{300} - 0.1663 = 0.6664 \text{ lb. in.}^2$ <p>B. There is too much system friction (drag) to allow the output inertia to fully disengage the clutch spring and engage the brake spring. Reduce system friction. Also, see Section A above on minimum inertia.</p> <p>C. The control tang is broken on the brake spring. Replace the spring, using the "Light Repair Kit."</p> <p>D. There is binding caused by rigid mounting. (See Section 2). Unit must not be rigidly mounted. The plate must be allowed to "float" axially.</p> <p>E. There is insufficient anti-back holding capability, or the unit has been reversed. See technical ratings for anti-back holding capabilities and re-evaluate sizing. Important: Do not reverse unit!</p> <p>F. An overhauling load is causing misregistration. Verify the unit has anti-overrun feature.</p> <p>G. The anti-overrun holding capacity has been exceeded. See technical ratings and re-evaluate unit sizing.</p>
Clutch	T _c	t	I _c																						
CB-2	1.65	0.003	0.0116																						
CB-4	4.40	0.004	0.0450																						
CB-5	6.88	0.004	0.1663																						
CB-6	8.75	0.005	1.221 (0.75 in. bore) 1.138 (1.0 in. bore)																						
CB-8	20	0.005	9.43 (.075 in. bore) 9.32 (1.0 in. bore) 8.15 (1.5 in. bore)																						

Troubleshooting Checklist (continued)

Possible Problem	Recommended Action
7. Poor Overall Life	<p>A. Rigid Mounting</p> <p>Rigid mounting of the rectangular backing plate will cause binding between the hubs and the shaft/output assembly. The backing plate is designed to serve as a torque arm and should not be rigidly mounted. Re-mount the unit to allow for some axial play between the mounting plate and mounting pin. (See Section 2)</p> <p>B. Incorrect Bearing Support</p> <p>Incorrect bearing support or sideloading of the input hub can cause excess wear. (See Section 2)</p> <p>C. Excessive side loading</p> <p>See incorrect bearing support above. (See Section 2)</p>

5. CB Spring Differential Adjustment

All CB and Super CB Series clutch/brakes are shipped from the factory with the proper spring differential overtravel setting. If the spring differential is incorrectly set, the clutch or brake spring may fail to engage or disengage properly. When units are assembled at the factory, and after the proper spring differential is set, for both the clutch and the brake springs, a punch mark is placed on either side of the slot where the spring tang is located (see Figure 7). If the unit must be disassembled, and the collar and springs are to be reused, ensure these marks are prevalent. Then, when reassembling the unit, place the spring tangs in the collar slots where the marks are and the differential setting will be returned to its original position.

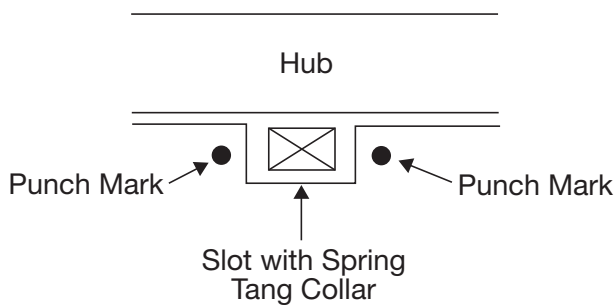

Figure 7

Measuring the Differential Setting

Rotate the clutch so the brake spring is fully wrapped down by rotating the output shaft in the driving direction until it cannot travel any farther. With the brake fully engaged (wrapped down), hold the output shaft with one hand and release the actuator. The stop collar will rotate forward as the brake is released and the clutch engages.

To determine the overtravel, use a scale to measure the distance between the tip of the actuator and the tip of the cam. (See Figure 8)

The amount of overtravel varies with the size of the unit:

CB-2	.09 to .19"
CB-4	.09 to .19"
CB-5/Super CB-5	.09 to .19"
CB-6/Super CB-6	.22 to .38"
CB-8/Super CB-8	.39 to .60"

Note: If the unit's overtravel falls within these specifications, then the spring differential setting is correct. If the overtravel falls outside these specifications, then follow the steps outlined below for "Setting the Spring Differential."

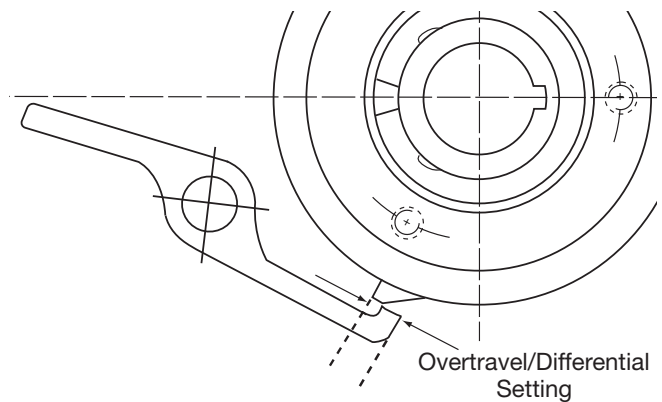
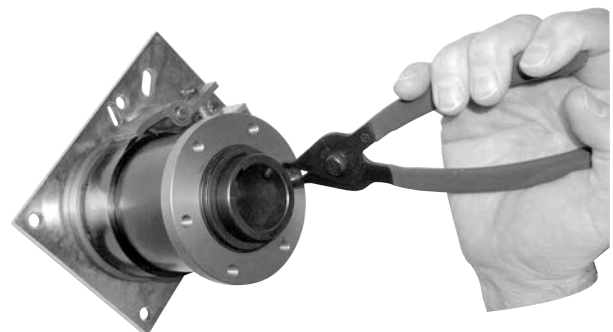
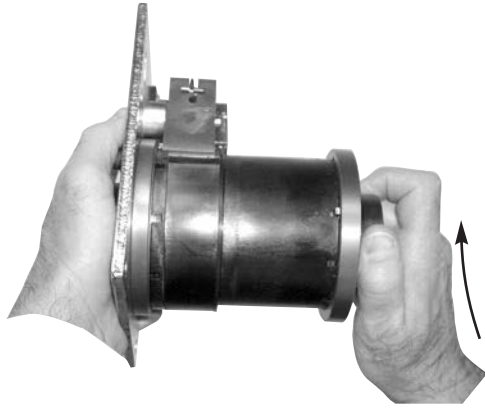

Figure 8

Setting the Spring Differential



If the differential setting is lost and the slots are unmarked, or if the collar or springs must be replaced, use the following procedure to reset the spring differential.



1. Using a retaining ring pliers, remove the retaining ring from the input hub.



2. Rotate the clutch so the brake spring is fully wrapped down by rotating the output shaft in the driving direction until it cannot travel any farther.

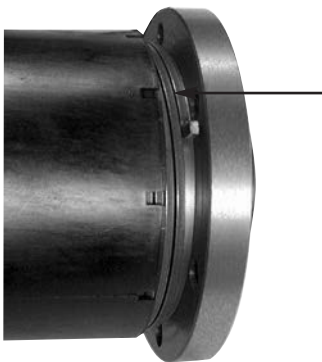

3. With the brake spring fully engaged (per step 2), pull the input hub assembly out, and use a small screwdriver to push the clutch spring out of its slot, allowing it to move to wherever it naturally comes to rest.



4. The clutch spring should come to rest between two slots. Unwrap the spring and push it backwards into the nearest slot.
5. Push the input hub back into place, release the actuator and rotate the clutch until the brake spring is again fully wrapped down. With the brake fully engaged, hold the output shaft with one hand and release the actuator. The stop collar will rotate forward as the brake is released and the clutch engages.
6. To determine the overtravel, use a scale to measure the distance between the tip of the actuator and the tip of the cam.

The amount of overtravel varies with the size of the unit:

CB-2	.09 to .19"
CB-4	.09 to .19"
CB-5/Super CB-5	.09 to .19"
CB-6/Super CB-6	.22 to .38"
CB-8/Super CB-8	.39 to .60"

7. If the overtravel measurement is within these specified limits, reinstall the retaining ring and the unit's overtravel is reset.
8. A. If the overtravel exceeds the specified limit, move the brake spring backwards one slot (against the direction of rotation) and repeat steps two through six.

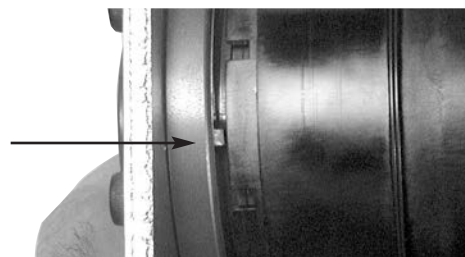

B. If the overtravel is less than the specified limit, move the brake spring forward one slot (in the direction of rotation), and repeat steps two through six.

Note: If the unit is disassembled and the drive and/or brake springs do not need to be replaced, and the original tang slots were marked proceed as follows:

- Reposition the clutch and brake springs into their original positions onto the output shaft assembly.
- Reassemble the clutch, and position the spring tangs of the clutch and brake springs in the factory marked locations on the control collar assembly (on the control collar, the designated tang slots are indicated with punch marks on either side of the slot).
- After the unit is completely reassembled, the differential setting should be returned to its factory setting.

- Made of a durable, flexible, soft plastic material
- Simple to install and remove
- Low cost

Model Number	Part Number
Dust Cover for CB-4	287-4-0002
Dust Cover for CB-5/Super CB-5	287-5-0007
Dust Cover for CB-6/Super CB-6	287-6-0007
Dust Cover for CB-8/Super CB-8	287-8-0003

6. Dust Covers



Dust covers for CB and Super CB models have been designed to protect the clutch/brake units from abrasives, corrosion, contaminants, and other harsh environmental elements.

Features:

- Protects models CB-4 through CB-8 and SCB-5 through SCB-8, from dirt and contaminants

Warranty

Warner Electric LLC warrants that it will repair or replace (whichever it deems advisable) any product manufactured and sold by it which proves to be defective in material or workmanship within a period of one (1) year from the date of original purchase for consumer, commercial or industrial use.

This warranty extends only to the original purchaser and is not transferable or assignable without Warner Electric LLC's prior consent.

Warranty service can be obtained in the U.S.A. by returning any defective product, transportation charges prepaid, to the appropriate Warner Electric LLC factory. Additional warranty information may be obtained by writing the Customer Satisfaction Department, Warner Electric LLC, 449 Gardner Street, South Beloit, Illinois 61080, or by calling 815-389-3771.

A purchase receipt or other proof of original purchase will be required before warranty service is rendered. If found defective under the terms of this warranty, repair or replacement will be made, without charge, together with a refund for transportation costs. If found not to be defective, you will be notified and, with your consent, the item will be repaired or replaced and returned to you at your expense.

This warranty covers normal use and does not cover damage or defect which results from alteration, accident, neglect, or improper installation, operation, or maintenance.

Some states do not allow limitation on how long an implied warranty lasts, so the above limitation may not apply to you.

Warner Electric LLC's obligation under this warranty is limited to the repair or replacement of the defective product and in no event shall Warner Electric LLC be liable for consequential, indirect, or incidental damages of any kind incurred by reason of the manufacture, sale or use of any defective product. Warner Electric LLC neither assumes nor authorizes any other person to give any other warranty or to assume any other obligation or liability on its behalf.

WITH RESPECT TO CONSUMER USE OF THE PRODUCT, ANY IMPLIED WARRANTIES WHICH THE CONSUMER MAY HAVE ARE LIMITED IN DURATION TO ONE YEAR FROM THE DATE OF ORIGINAL CONSUMER PURCHASE. WITH RESPECT TO COMMERCIAL AND INDUSTRIAL USES OF THE PRODUCT, THE FOREGOING WARRANTY IS IN LIEU OF AND EXCLUDES ALL OTHER WARRANTIES, WHETHER EXPRESSED OR IMPLIED BY OPERATION OF LAW OR OTHERWISE, INCLUDING, BUT NOT LIMITED TO, ANY IMPLIED WARRANTIES OF MERCHANTABILITY OR FITNESS.

Some states do not allow the exclusion or limitation of incidental or consequential damages, so the above limitation or exclusion may not apply to you. This warranty gives you specific legal rights and you may also have other rights which vary from state to state.

Changes in Dimensions and Specifications

All dimensions and specifications shown in Warner Electric catalogs are subject to change without notice. Weights do not include weight of boxing for shipment. Certified prints will be furnished without charge on request to Warner Electric.



Warner Electric LLC
31 Industrial Park Road • New Hartford, CT 06057
815-389-3771 • Fax: 815-389-2582
www.warnerelectric.com
An Altra Industrial Motion Company