

Complete Interface Design and 24-axis Motion Control



**CANopen Motion Controller
DVP15MC**

**EtherCAT Motion Controller
DVP50MC**

- ▶ 1GHz CPU
- ▶ Program capacity + data capacity = 20MB + 20MB
- ▶ Up to 24 real axes control

Built-in Interface

16DI
8DO

RS-232

RS485

Ethernet
15MC: x2
50MC: x1

Memory
card:SD

CANopen
DS301

Motion
15MC: CANopen
DS402
50MC: EtherCAT

Incremental
encoder
interface*2

SSI absolute
encoder
interface

Motion Function

Multi-axis Gear
/ Cam

Linear / Arc
/ Helical
interpolation

Jerk

G-Code

Buffer
Mode

Multi-axis Motion Controller

DVP-MC

16-axis Motion Controller

DVP10MC11T

Perfect controller to offer highly stable multi-axis motion control solutions through CANopen communication

- ▶ Built-in 12 I/O points (8 sets of high-speed inputs, 4 sets of high-speed outputs)
- ▶ Up to 16 axes synchronous control through CANopen communication
- ▶ Synchronization time: 4 axes in 2ms / 8 axes in 4ms
- ▶ Built-in motion control instructions of electronic cam, flying shear, rotary cut for easy operation
- ▶ High precision control with interpolation function

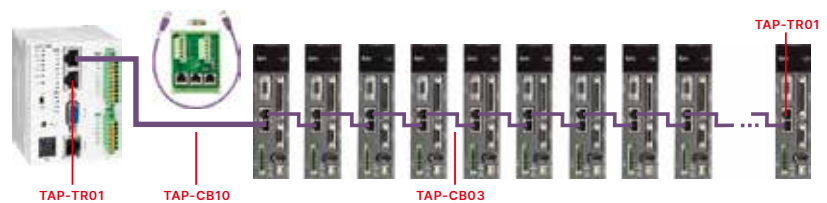

System Control Architecture

Extensions (left-side)

- Supports DVP-S Series modules (left-side):
 - CANopen master
 - DeviceNet master
 - PROFIBUS slave
 - load cell modules

Accessories

Standard CANopen communication cables, terminal resistor and distribution box

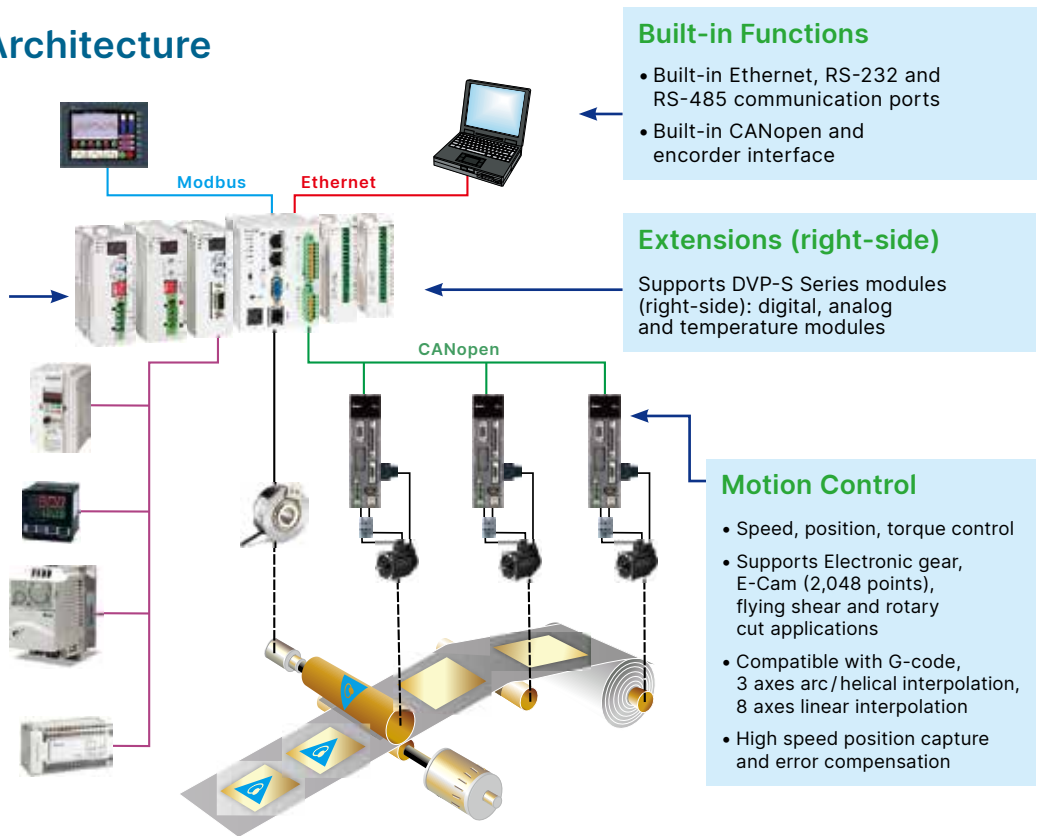

Built-in Functions

- Built-in Ethernet, RS-232 and RS-485 communication ports
- Built-in CANopen and encoder interface

Extensions (right-side)

Supports DVP-S Series modules (right-side): digital, analog and temperature modules

Motion Control

- Speed, position, torque control
- Supports Electronic gear, E-Cam (2,048 points), flying shear and rotary cut applications
- Compatible with G-code, 3 axes arc / helical interpolation, 8 axes linear interpolation
- High speed position capture and error compensation

CANopen Accessories		
Model Name	Specifications	Features
UC-CMCXXX-01A	CANopen sub-line	RJ45 connector for both ends
UC-DN01Z-01A / 02A	CANopen main-line / sub-line	AWG18 / AWG24 CANopen cables for long distance communication via CANopen
TAP-CN01 / 02 / 03	Distribution box	Built-in terminal resistor 120 Ω
TAP-TR01	Terminal resistor	Terminal resistor 120 Ω

Multi-axis Motion Controller

DVP15MC / DVP50MC New

The DVP15MC/DVP50MC Series is a multi-axis motion controller designed for the CANopen / EtherCAT network architecture. It supports CANopen/EtherCAT with built-in motion control instructions (BufferMode and Jerk) for flexible configuration and fast project development. DVP15MC/DVP50MC controls up to 24 real axes via Motion port. It also supports single axis motion control instructions such as speed, position, torque, homing, position setup and multi-axis motion control instructions such as electronic gear, electronic cam (E-Cam), rotatory cut and G-code.

DVP15MC/DVP50MC features multiple built-in communication interfaces, and can be easily connected to other equipment without additional communication modules. It also provides high-speed and reliable motion control via CANopen/EtherCAT for printing, packaging, wire cutting, robots and other automation control industries.

Motion Control

- Up to 24 real axes control (virtual axis no.: 1~32, can't be repetitive with real axis no.)
- Built-in motion control instructions and easy to use
- Supports encoder axis and virtual axis
- Single axis motion control instructions: speed, torque, homing, and position setup
- Application instructions: electronic gear, E-Cam, and rotary cut
- G-code: 8 axes linear / arc / helical interpolation
- Coordinates motion control instructions

Performance

- 1GHZ high-speed floating point operation
- High-precision computing: supports LREAL (Double-precision floating-point format)
- Synchronization time:
 - DVP15MC: 4 axes in 2ms, 8 axes in 4ms
 - DVP50MC: 32 axes in 1ms
- Program capacity: 20 MB
- Data capacity: 20 MB

External Interfaces

- 1 CANopen port as host or slave station
- 1 Motion port (DVP15MC: CANopen, DVP50MC: EtherCAT)
- 16 high-speed inputs / 8 high-speed outputs
- 2 incremental encoder interfaces
- 1 SSI absolute encoder interface
- Ethernet port: DVP15MC x2, DVP50MC x1
- 1 SD card slot
- 1 RS-232 port and 1 RS-485 port
- Extension:
 - Left-side: supports up to 8 DVP-S Series modules (AIO / PROFIBUS Slave)
 - Right-side: compatible with DVP-S Series modules (240 DI, 240 DO and 8 special modules)

Motion Network and Wiring

- DVP15MC
 - Motion network: CANopen
 - Communication speed: Max. 1Mbps
 - Distance: Max. 100m (at 500 kbps)
- DVP50MC
 - Motion network: EtherCAT
 - Communication speed: Max. 100Mbps
 - Distance: Max. 50m (Node-to-node)
- Simple wiring, plug-and-play



DVP15MC / DVP50MC Interface

Multiple built-in communication interfaces allow easy connection to other equipment without additional communication modules.

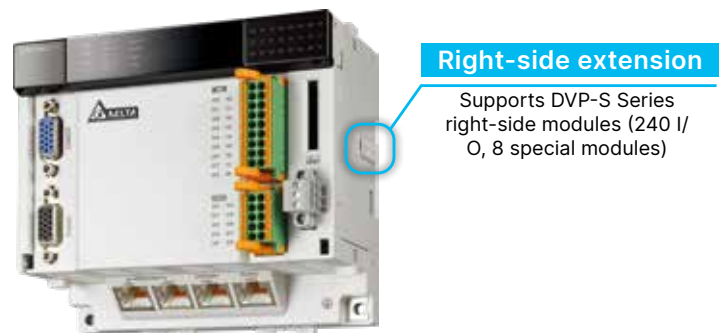
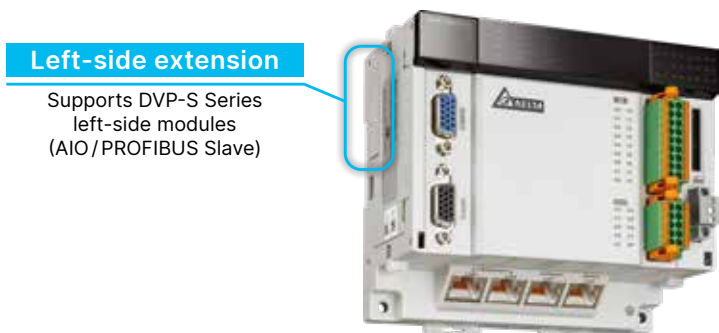
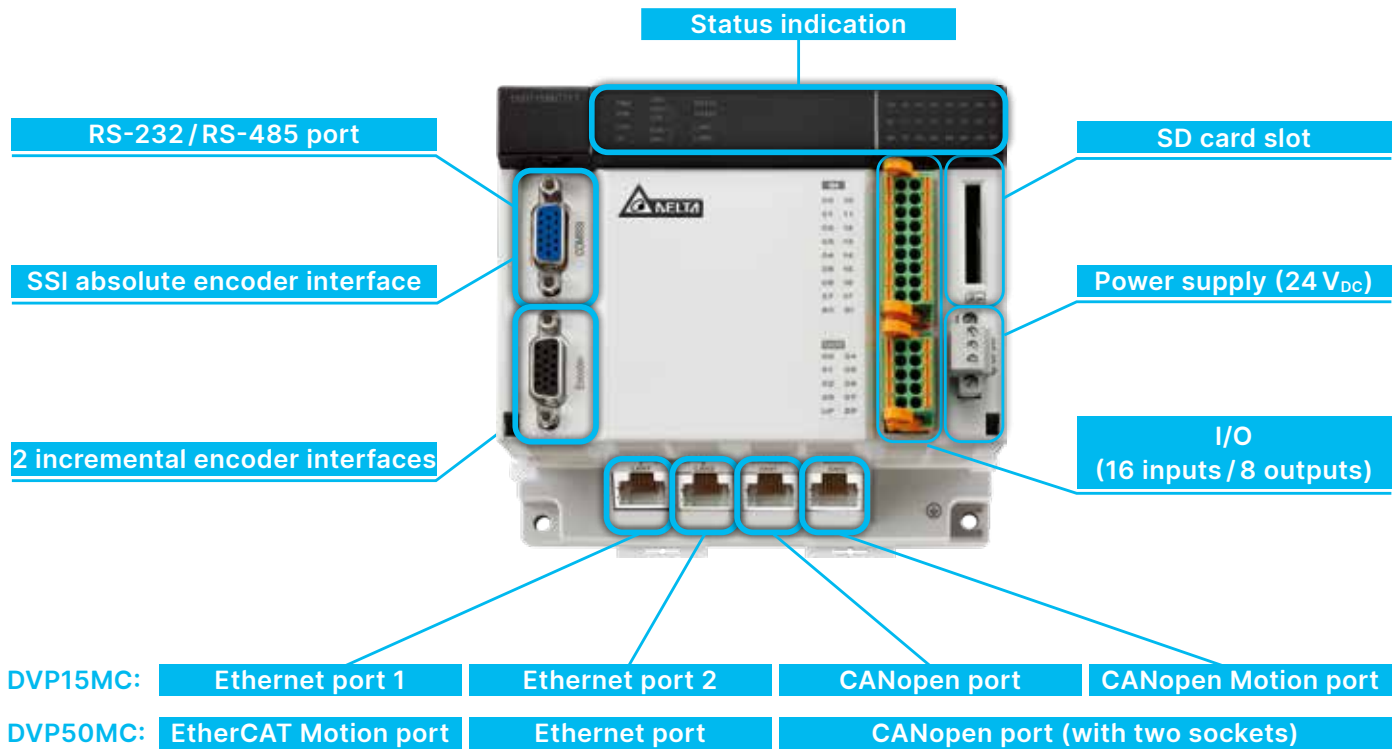

Simple Wiring, Plug-and-Play Motion Control Network

The DVP15MC / DVP50MC features stable CANopen / EtherCAT communication, simple wiring, plug-and-play functions, and communicates with servo drives (axes) via CANopen/EtherCAT network. Delta provides communication cable, terminal resistor and distribution box.

*Please refer to "Accessories" for detailed information

DVP15MC:

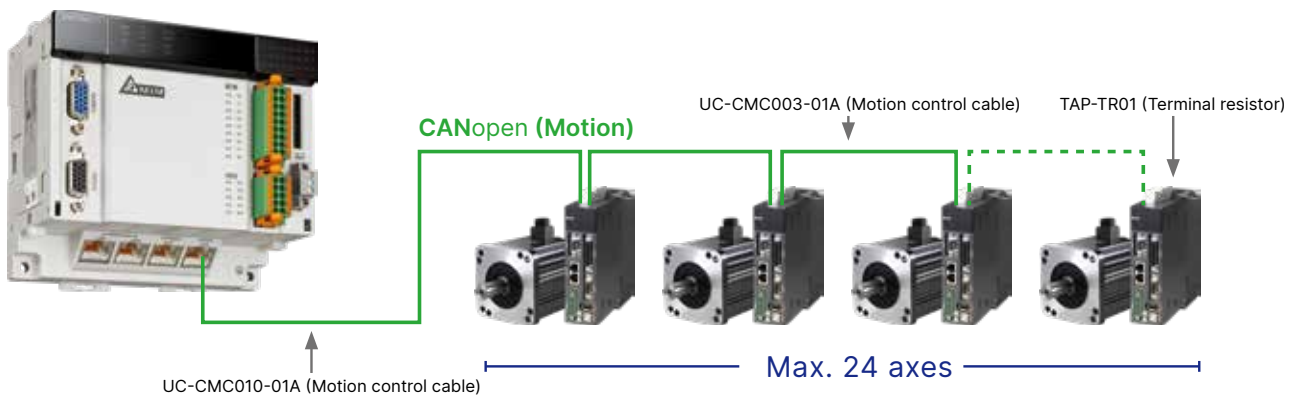

DVP50MC:

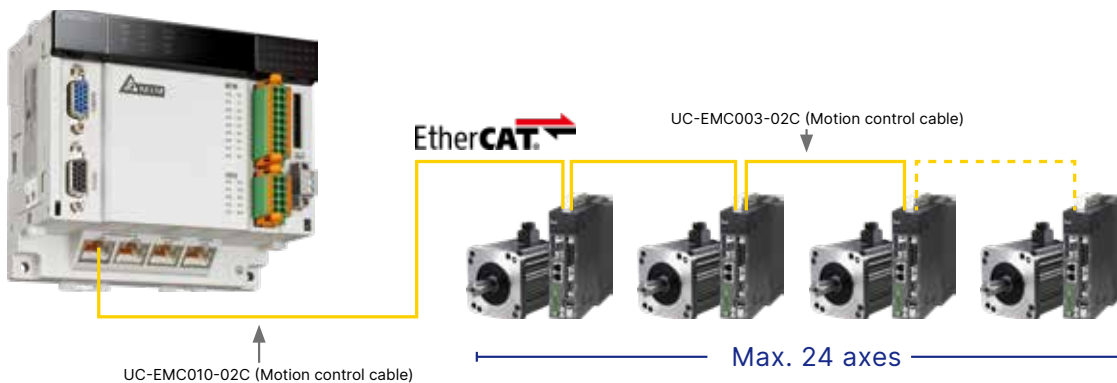

Compatible with Servo Drives via Motion Port

- Delta's AC Motor Drives ASDA-A2-XXXX*-M / ASDA-A2-XXXX*-MN models support CANopen communication, and they are the only models that can be connected to a DVP10MC11T for motion control networks.
- Delta's AC Motor Drives ASDA-A3-XXXX*-M / ASDA-A2-XXXX*-M / ASDA-B3-XXXX*-M models support CANopen communication, and they are the only models that can be connected to a DVP15MC CANopen (Motion) port for motion control networks.
- Delta's AC Motor Drives ASDA-A3-XXXX*-E / ASDA-A2-XXXX*-E / ASDA-B3-XXXX*-E models support EtherCAT communication, and they are the only models that can be connected to a DVP50MC EtherCAT (Motion) port for motion control networks.

The standard CANopen port of DVP15MC / DVP50MC can be connected to all equipment that supports CANopen networks. The ASDA-A3 / A2 / B3 Series models provide high positioning accuracy and low-speed operation stability.

* XXXX represents output power and input voltage



System Structure

DVP15MC/DVP50MC provides multiple industrial networks. As in the structure shown below, DVP15MC/DVP50MC can be connected to a variety of industrial automation equipment via Ethernet (upper layer), EtherCAT, CANopen, DeviceNet, PROFIBUS DP (middle layer) and RS-485 (lower layer, support Modbus).

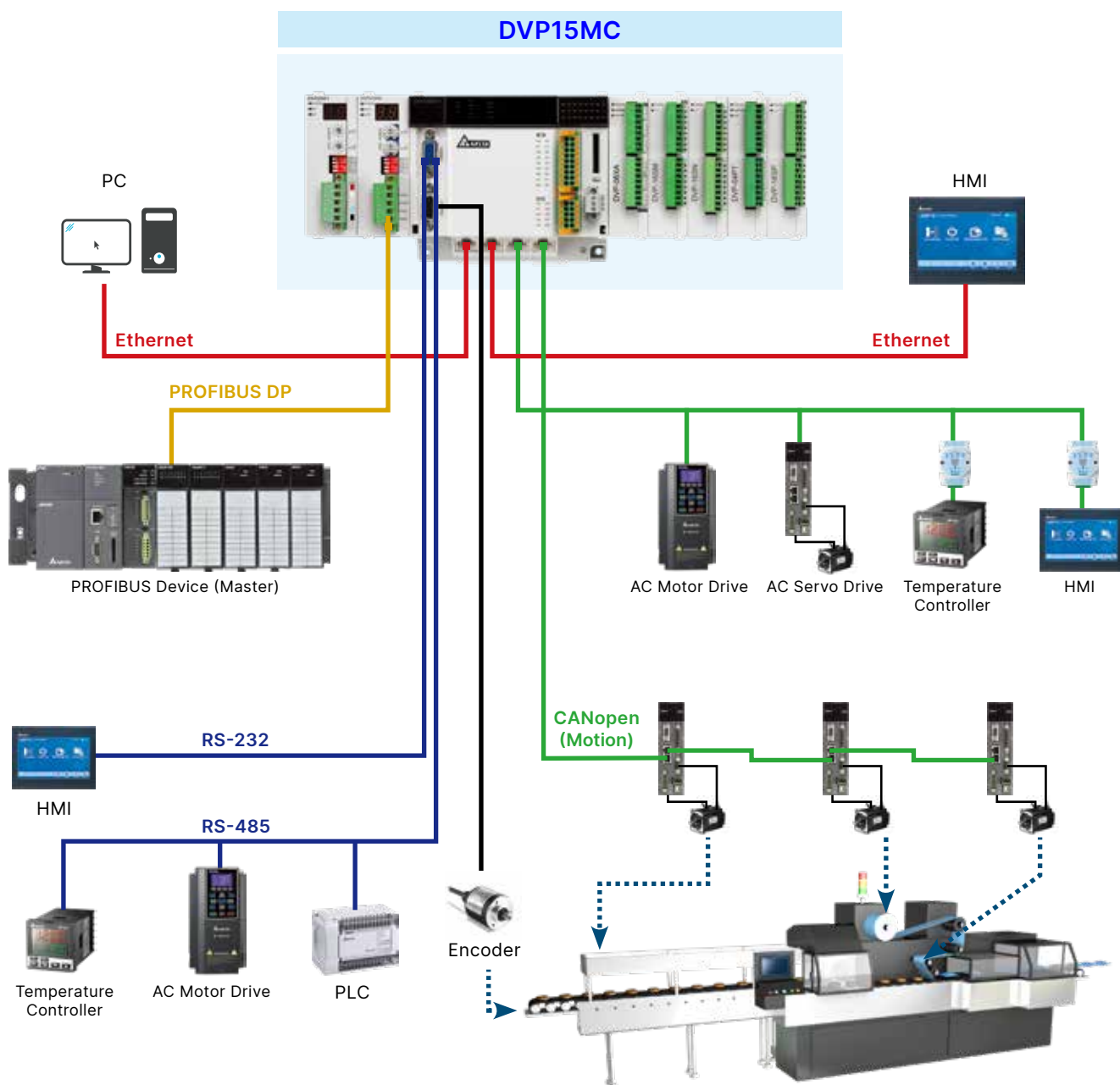

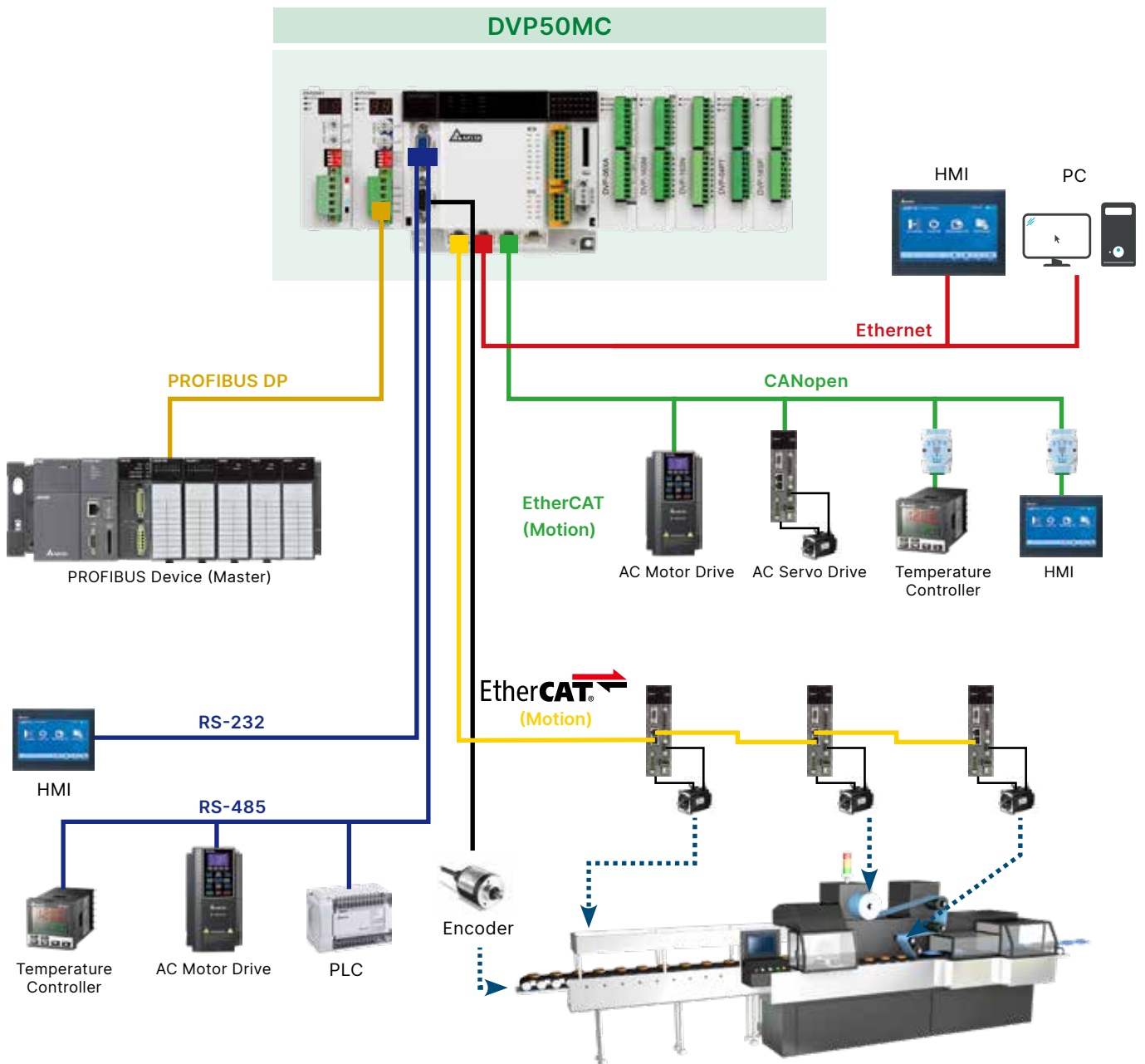

Motion Control

Supports BufferMode and Jerk motion instructions:

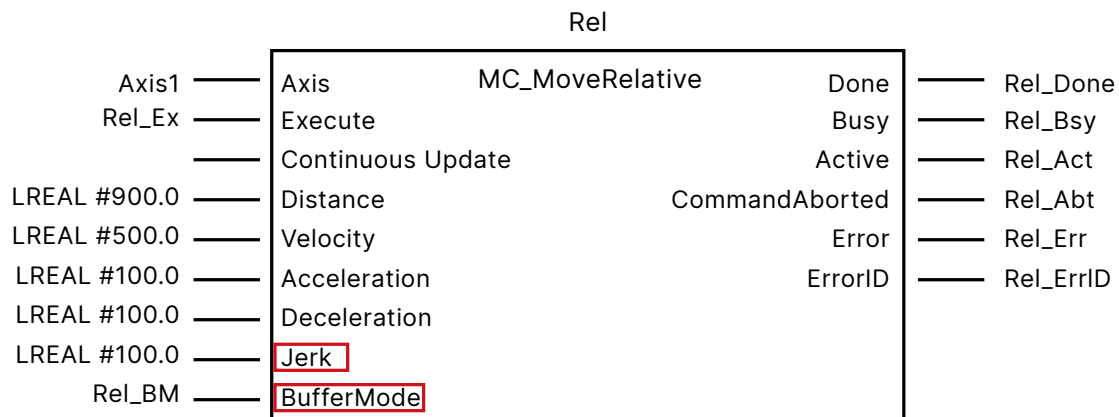

Supports Jerk motion instruction:

Modifies the Jerk value to make the velocity curve smoother

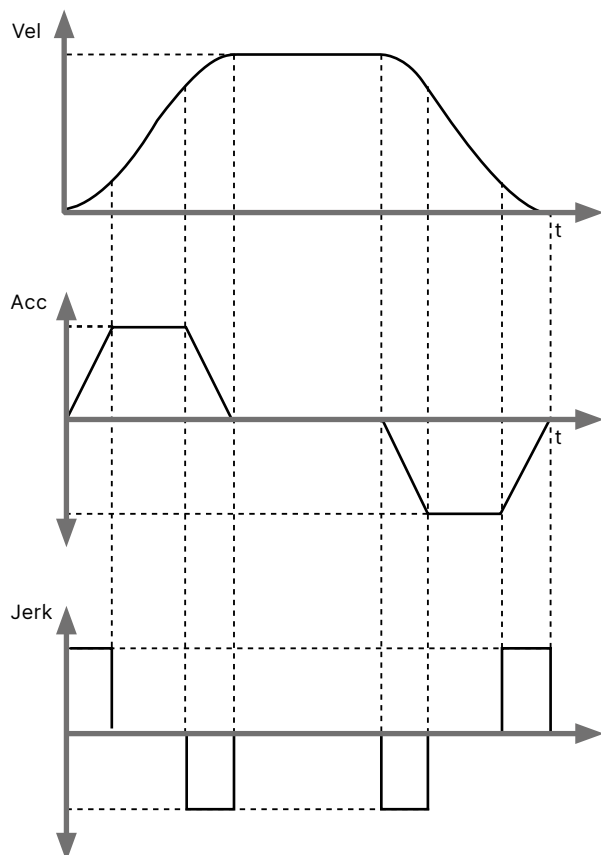

Supports BufferMode motion instruction:

Enables smooth transition between 2 instructions

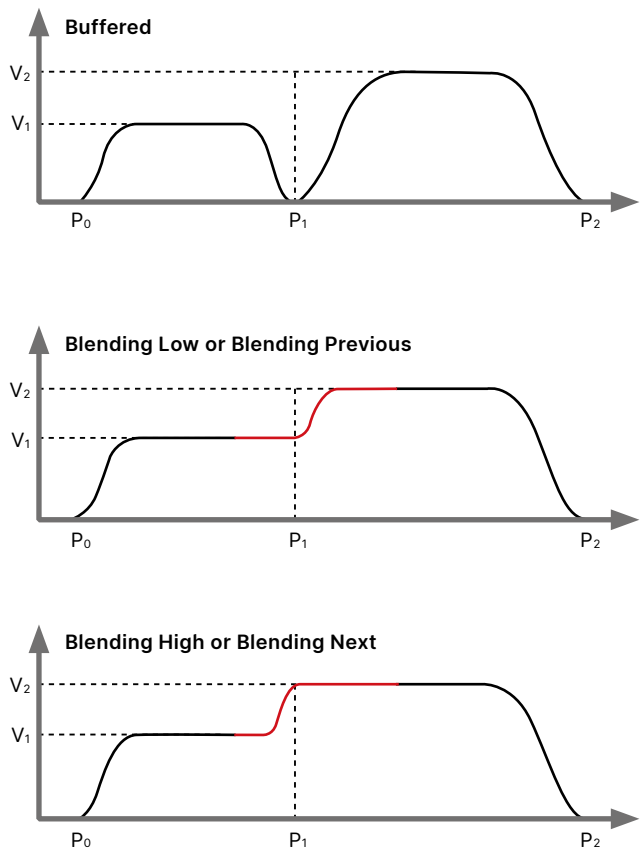

CANopen Configuration Software: CANopen Builder

- Features network arrangement, motion control programming, G-code editor / graph preview and E-Cam curve planning
- Supports international standard function blocks for motion control, enhancing program editing efficiency

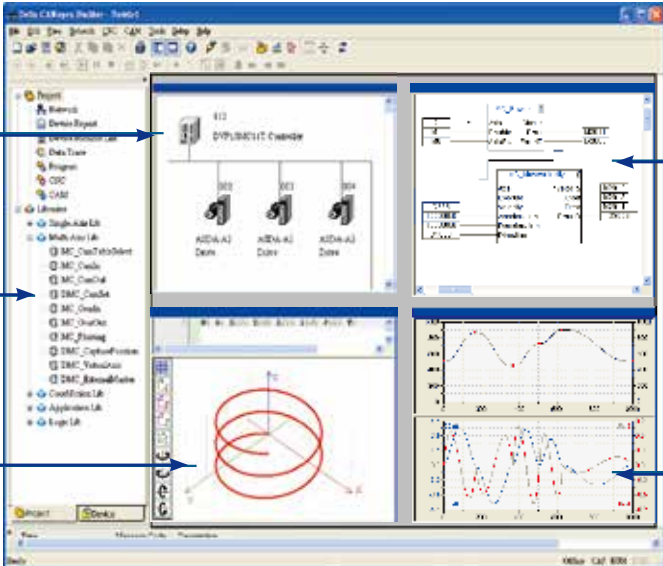

- Network Arrangement**
 Network scanning for listing all the equipment
- Motion Control**
 Supports international standard function blocks for motion control
- G-code Editor and Preview**
 G-code editing and preview, direct DXF files import available

- Program Editing**
 CFC, LD, ST, function blocks connection and syntax check
- E-Cam Curve Planning**
 Allows users to plan E-Cam curves according to their needs for more complex control

Professional Motion Control Applications

Designed as the most outstanding and economical motion controller, the DVP-PM Series provides flying shear, rotary cut, electronic cam and many advanced functions to achieve highly precise motion control

Robot Arm

Electronic Cam (E-Cam) function enables the robot arm to perform multi-axis control. After the required positions are memorized in the PLC, users can enable the electronic cam function to create the E-Cam profile and conduct trajectory tracking and multi-axes motion control required in robot arm applications.



High-Speed Cutting Machine

Average PLC cutting motion is limited by operation speed, poor synchronization, large amounts of calculations and long CPU processing time, resulting in a disproportionate cutting result and affecting the quality of end products. The basic demands, however, can be fulfilled under low speed while rough surface and low quality appear under high speed. The electronic cam function offered by DVP-PM and DVP-MC is able to generate dynamic cam curves for rotary cutting to ensure precise cutting results.



Digital Board Cutting Machine

The DVP-PM Series' built-in flying shear function is able to complete synchronous conveyance and cutting speed, and ensures precise cutting results on conveyor belts.





























CNC Lathe

The DVP-PM Series controls multi-axis motion. Two axes complete the motion by linear or arc interpolation, and the other two work independently, controlling the independent or synchronous ascending/descending of the vertical axis on two sides.



Slim PLC DVP-S Series Extension Modules

High-speed Extension Modules (left-side) ^{*1}	General Extension Modules (right-side) ^{*2}		
<p>Network Modules</p> <ul style="list-style-type: none"> ■ DeviceNet Master DVDPNET-SL  ■ CANopen Master DVPCOPM-SL  ■ Ethernet DVPEN01-SL  ■ PROFIBUS-DP Slave DVPPF02-SL  ■ RS-422 / RS-485 Serial Communication Module DVPSM12-SL  ■ BACnet MS / TP Slave Serial Communication Module  <p>Analog Extension</p> <ul style="list-style-type: none"> ■ Analog Input DVP04AD-SL  ■ Analog Output DVP04DA-SL  <p>Load Cell / Tension</p> <ul style="list-style-type: none"> ■ Load Cell Module DVP01LC-SL DVP02LC-SL DVP201LC-SL DVP211LC-SL DVP202LC-SL  	<p>I/O Point Extension</p> <ul style="list-style-type: none"> ■ Input Point Extension DVP08SM11N DVP16SM11N  ■ Output Point Extension DVP06SN11R DVP08SN11R/T DVP08SN11TS DVP16SN11T DVP16SN11TS  ■ Input / Output Point Extension DVP08SP11R / T DVP08SP11TS DVP16SP11R / T DVP16SP11TS  ■ Pin Header Input DVP32SM11N  ■ Pin Header Output DVP32SN11TN  ■ Digital Switch DVP08ST11N  <p>Analog Extension</p> <ul style="list-style-type: none"> ■ Analog Input DVP04AD-S DVP06AD-S DVP04AD-S2  ■ Analog Output DVP04DA-S DVP02DA-S DVP04DA-S2  ■ Analog Input / Output DVP06XA-S DVP06XA-S2  <p>Temperature Measurement</p> <ul style="list-style-type: none"> ■ Sensor: Pt100, Pt1000 DVP04PT-S DVP06PT-S  ■ Sensor: J,K,R,S,T thermocouple DVP04TC-S  ■ Sensor: New NTC thermistor DVP08NTC-S  ■ Temperature Control: DVP02TUN-S DVP02TUR-S DVP02TUL-S  ■ Remote Temperature Control Module: DVP02TKN-S DVP02TKR-S DVP02TKL-S  <p>Communication Modules</p> <ul style="list-style-type: none"> ■ PROFIBUS Slave DVPPF01-S  ■ DeviceNet Slave DVPDT01-S  <p>Power Supply Modules</p> <ul style="list-style-type: none"> DVPPS01 DVPPS02 DVPPS05  <p>Axis Control Module</p> <ul style="list-style-type: none"> ■ Single-Axis Positioning DVP01PU-S  		

*1. DVP32EH00R3-L & DVP32EH00T3-L are also compatible with the left-side high-speed extension modules
 *2. Max. quantity of right-side extension module is 14, among which the quantity of -S and -S2 modules must be equal to or less than 8. If the total quantity of extension modules is over 14, applying high density extension modules is recommended