

## Recommended Shaft End Shape For Support Unit Type BK and FK and EK Fixed Side

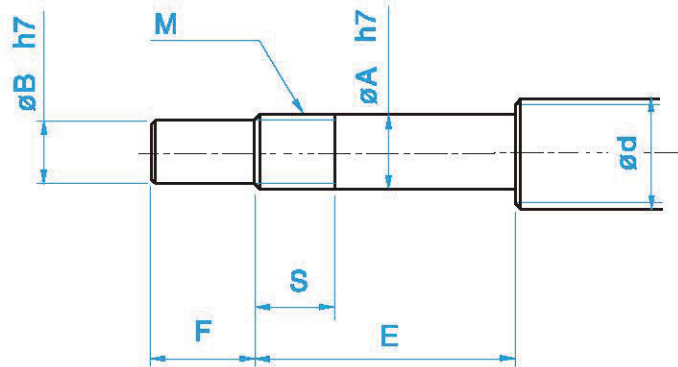

Unit:mm

Support Unit model No.	Ball Screw shaft OD	Shaft Support Portion OD				Metric screw thread	
Type BK	d	A	B	E	F	M	S
BK 10	12/14/15	10	8	36	15	M10X1	16
BK 12	14/15/16	12	10	36	15	M12X1	14
BK 15	18/20	15	12	40	20	M15X1	12
BK 17	20/25	17	15	53	23	M17X1	17
BK 20	25/28	20	17	53	25	M20X1	15
BK 25	32/36	25	20	65	30	M25X1.5	18
BK 30	36/40	30	25	72	38	M30X1.5	25
BK 35	45	35	30	81	45	M35X1.5	28
BK 40	50	40	35	93	50	M40X1.5	35

Unit:mm

Support Unit model No.		Ball Screw shaft OD	Shaft Support Portion OD				Metric screw thread	
Type FK	Type EK	d	A	B	E	F	M	S
FK 6	EK 6	8	6	4	28	8	M6X0.75	8
FK 8	EK 8	10/12	8	6	32	9	M8X1	10
FK 10	EK 10	12/14/15	10	8	36	15	M10X1	11
FK 12	EK 12	14/15/16	12	10	36	15	M12X1	11
FK 15	EK 15	18/20	15	12	47	20	M15X1	13
FK 20	EK 20	25/28/30	20	17	62	25	M20X1	17
FK 25	—	30/32/36	25	20	76	30	M25X1.5	20
FK 30	—	36/40	30	25	72	38	M30X1.5	25

## Recommended Shaft End Shape For Support Unit Types FF and EF and BF Floated Side

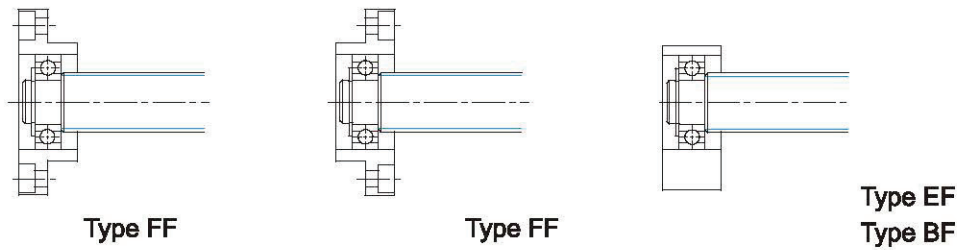

Unit:mm

Support Unit model No.			Ball Screw shaft OD	Shaft Support Portion OD
Type FF	Type EF	Type BF	d	A
FF 10	EF 10	BF 10	12/14/15	8
FF 12	EF 12	BF 12	14/15/16	10
FF 15	EF 15	BF 15	18/20	15
FF 17	—	BF 17	20/25	17
FF 20	EF 20	BF20 (NOTE)	25/28/30	20
FF 25	—	BF 25	30/32/36	25
FF 30	—	BF 30	36/40	30
—	—	BF 35	40/45	35
—	—	BF 40	50	40

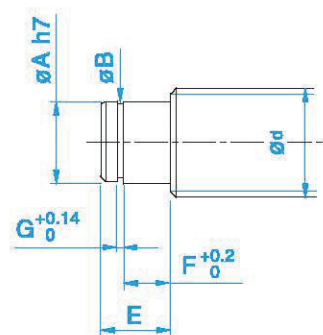

Note:

In this table, dimensions in parentheses are those of type BF20. These dimensions differ from those of type FF20 and EF20. When placing an order, always specify the model number of the Support Unit to be used.

Unit:mm

E	Snap-ring Groove		
	B	F	G
10	7.6	7	0.9
11	9.6	8	1.15
13	14.3	9	1.15
16	16.2	12	1.15
19(16)	19	14(12)	1.35
20	23.9	15	1.35
21	28.6	16	1.75
22	33	17	1.75
23	38	18	1.75