

Goodrive350 Series

High-performance Multi-function VFD

Your trusted industry automation solution provider

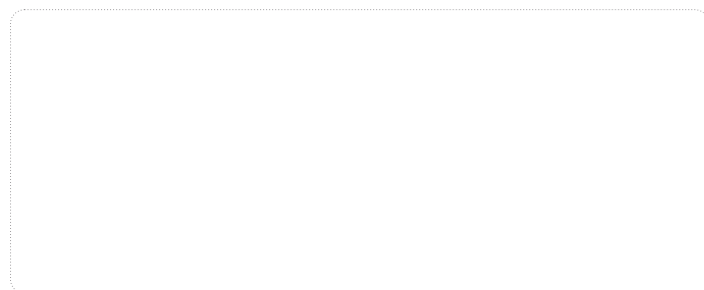

Service line: 86-755-23535967 E-mail: overseas@invt.com.cn Website: www.invt.com

SHENZHEN INVT ELECTRIC CO.,LTD. INVT Guangming Technology Building, Songbai Road, Matian, Guangming District, Shenzhen, China

- Industrial Automation:**
- Variable-Frequency Drive
 - HMI
 - SVG
 - New Energy Vehicle Electric Control System
 - Servo & Motion Control
 - Intelligent Elevator Control System
 - Solar Pump Controller
 - UPS
 - Motor & Electric Spindle
 - Traction Drive
 - Online Energy Management System
 - PLC

INVT Copyright.
Information may be subject to change without notice during product improving.

66003-00162 Y9/1-11(V2.0)



Goodrive350

- Introduction 2
- Product Advantages 3
- Application Scenarios12
- Technical Specification13
- Type Selection14
- Installation Dimensions16
- Optional Parts22

Goodrive350 IP54

- Introduction31
- Technical Specification32
- Type Selection33
- Installation Dimensions34
- Optional Parts36



Introduction

GD350 is a brand new high-performance VFD which integrates the speed, torque, and position control. It is widely applicable to control over synchronous and asynchronous motors. It is highly extensible and flexible with PG card, PLC card, communication card and IO card, meeting the demands of various industries. It's oriented for mid&high end OEM market, mainly covering printing, packaging, winding, etc.



Features

- Support SVC and VC(Closed loop) control for both asynchronous and synchronous motors.
- Enable high precision of speed, position, torque control and fast speed response.
- Support Ethernet/IP, Profinet, CAN Master/Slave, etc.
- Accept plug-in of three expansion cards simultaneously (only two cards ≤ 7.5kW(10HP).
- Integrate safety function-STO(Safe Torque OFF, SIL2).
- Unique I/F control and online transition with other control modes are very suitable for the situation where the asynchronous motor has low speed with high torque and the speed accuracy is not high.
- Multi-function LCD keyboard.
- Support optional Bluetooth card and WIFI card.

Control performance

- New-type flux linkage observer, improving the stability of the high-speed control.
- New-type speed/current regulator, improving the current control result in quick start and reducing speed overshoot.
- New-type phase-locked loop, improving the stability of high-torque control.
- Compensation for output voltage phases and amplitude, improving the stability of high- and low-speed carriers.
- Adding the synchronous motor VF control mode based on reactive current control. The output current adapts to the load and the oscillation suppression algorithm.

Product Advantage

Full motion and all-round

Performance improvement

Compared with the products of last generation, the performance is significantly improved



Motor auto-tuning

- Asynchronous motor—Eliminates the impact of the skin effect, improving the auto-tuning precision.
- Synchronous motor—Performs auto-tuning on the counter-electromotive force, effectively avoids the impact of the initial value of the counter-electromotive force.

DC braking

- The current change is smoother in the process of the motor entering DC braking from rotating, the current shock is weak, and the current response is faster.

Rotating speed tracking

- In any of the control modes, the rotating speed tracking method brings the least current shock, and thus significantly improves the stability.

High torque at low speed

- Special I/F control, featuring constant current source, highly applicable to scenarios where multiple motors are to be driven simultaneously and high torque is required at low speed.

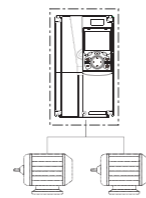

State	IO/IN(M)(%)	
	Multi-point VF	I/F control
Before and after brake open in forward running	62.80%	133.40%
Before and after brake open in reverse running	62.50%	130.30%
Before and after brake close in forward running	65.70%	136.10%
Before and after brake close in reverse running	92.00%	136.30%

Data measured on a construction machinery site

Drive multiple motors

Applicable to drive various motors

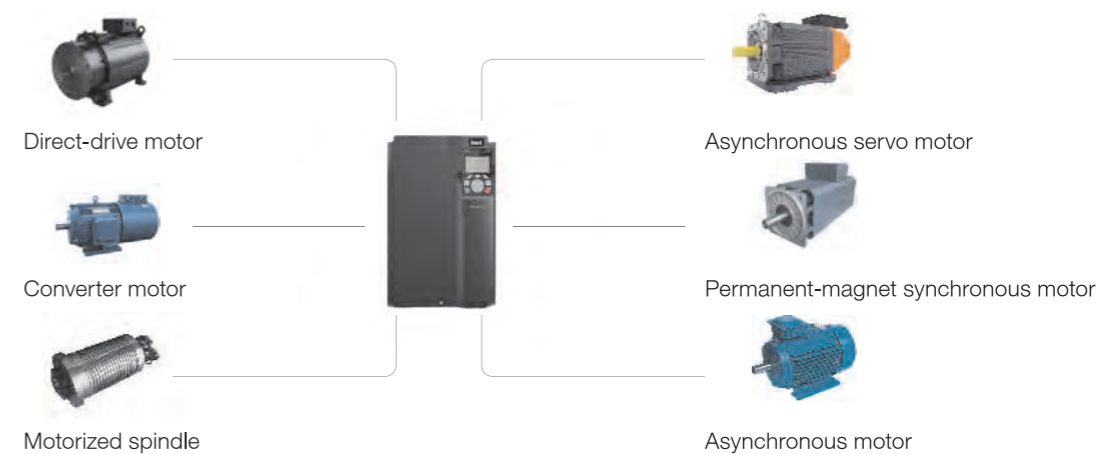

Combine different controls

More precise, stronger torque, speed, and position control over motors

Characteristic indicator	Goodrive350
Position control precision	±1 pulse

(2) Torque and speed control performance—Ensure stable mechanical operation, fast response, and low torque ripple

Characteristic indicator	Goodrive350
Speed regulation range	1:1000
Speed stabilization precision	+0.02%
Response time in torque control	<10ms
Torque control precision	5%
Start frequency/higher start torque	0Hz/200%

Keep running when power down

When the grid encounters a momentary power outage, the VFD can keep running by using the fed-back energy within a certain period of time.

It is highly applicable to chemical fiber and textile production lines and other scenarios where the device is Required to run continuously.

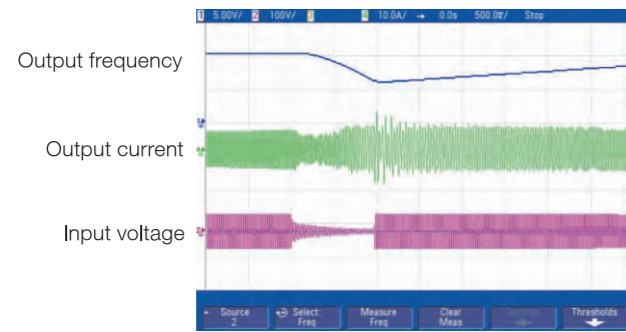

Multiple braking modes to enable fast stop

Dynamic braking	DC braking	Magnetic braking	Short-circuit braking
High torque fast speed	No brake unit or brake resistor required	No brake unit or brake resistor required; allowing fast braking	No brake unit or brake resistor required; allowing fast braking
Large-inertia loads scenarios are frequently braked	Applicable to scenarios where freely running motors are to be braked first and then started and where torque output needs to be kept after the motor is braked to run at the speed of zero	Applicable to scenarios where large-inertia loads are to be fast stopped at low frequency	Applicable only to fast stop of PMSMs or braking and then starting freely running PMSMs

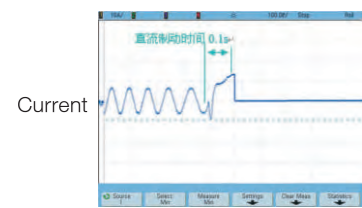

Current wave in the SVPWM mode for asynchronous motors
Frequency: 10Hz
Braking current: 100%

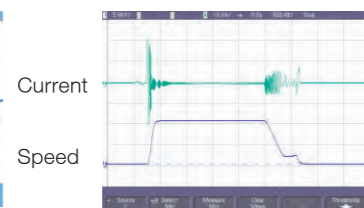

PMSM short-circuit braking wave
Acceleration time: 0.1s
Deceleration time is 0.4s

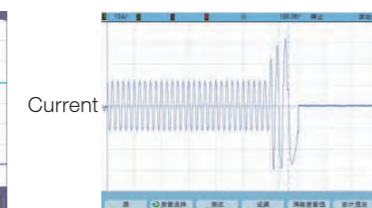

Magnetic flux braking current wave in the SVPWM mode for asynchronous motors
Frequency: 50Hz
Rated load: 100%

Proper voltage and current control, effectively reducing the number of VFD fault protection times

Overtoltage stall	Overcurrent stall
Regulates the output frequency during deceleration to prevent the motor from generating too much power due to too fast deceleration	Regulates the output frequency during acceleration to prevent too heavy loads caused due to too fast acceleration

Excellent driving performance on special motors

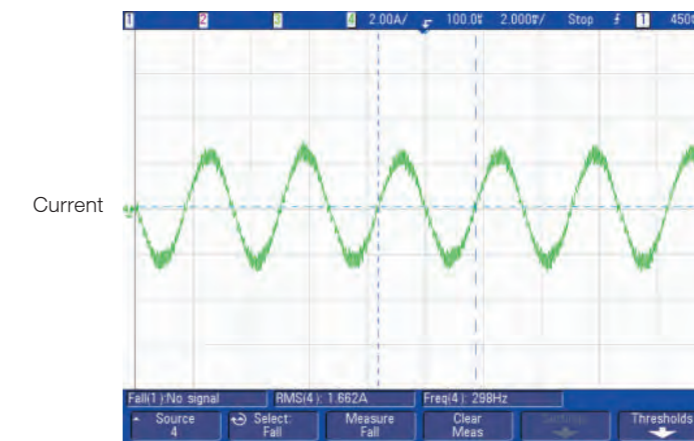

Current wave at 300 Hz with 100% of the rated load in the open-loop vector control mode for synchronous motors

Multi-function

Enhanced extension performance

- (1) Optional PLC, I/O, communication, and PG cards
- (2) Consistent extension card dimensions

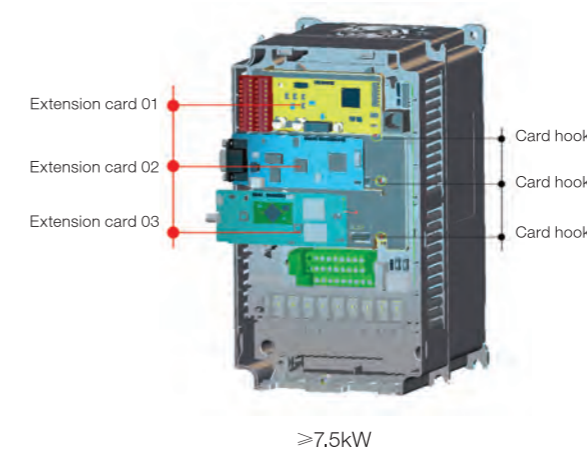

≥7.5kW

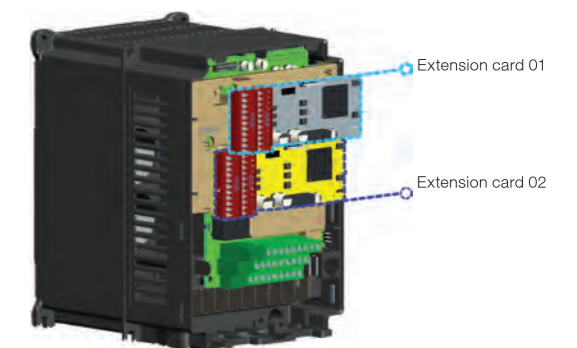

≤5.5kW

Supporting customers' secondary development

- (1) Meeting customization requirements, reducing customers' costs, and improving the processes
- (2) Optional PLC card, 128 k program memory space



Standard two HDIs that can serve as speed sources or high-speed AB pulse inputs, which can be used for simple closed-loop application



Supporting various industrial communication protocols

- (1) Standard Modbus communication, supporting the following communication modes based on extension cards

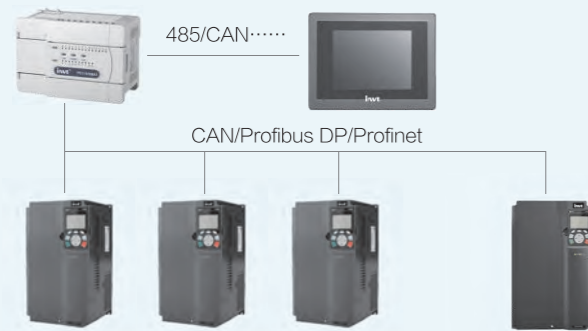

Supporting built-in brake units at a maximum of 110 kW, reducing customers' costs and installation space

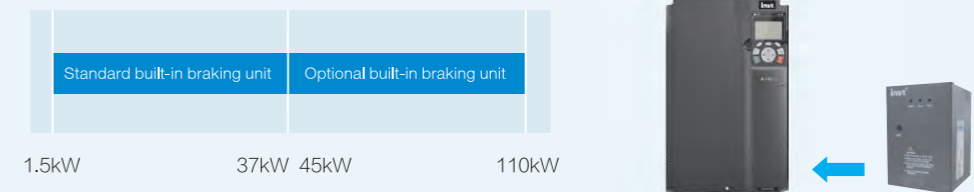

Adopting the digital filtering technology that improves EMC; the anti-interference performance is twice that of conventional solutions

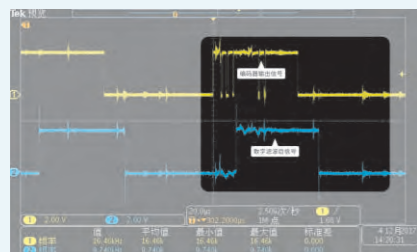

Encoder signal: near-field coupling of 100m motor wire

- (1) Supporting pulse reference and frequency-divided output;
- (2) providing the fast encoder disconnection detection function to prevent the expansion of the system fault impact

Providing built-in DC reactors for models of 18.5 kW–110 kW

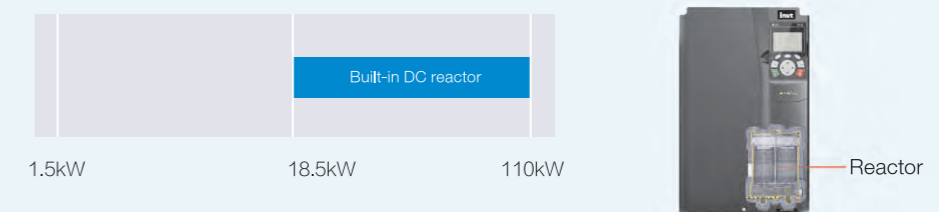

Built-in C3 input filters; optional C2 filters for 380V models

Built-in C3 input filters of 380 V in factory reduce external installation space and prevents electromagnetic interference

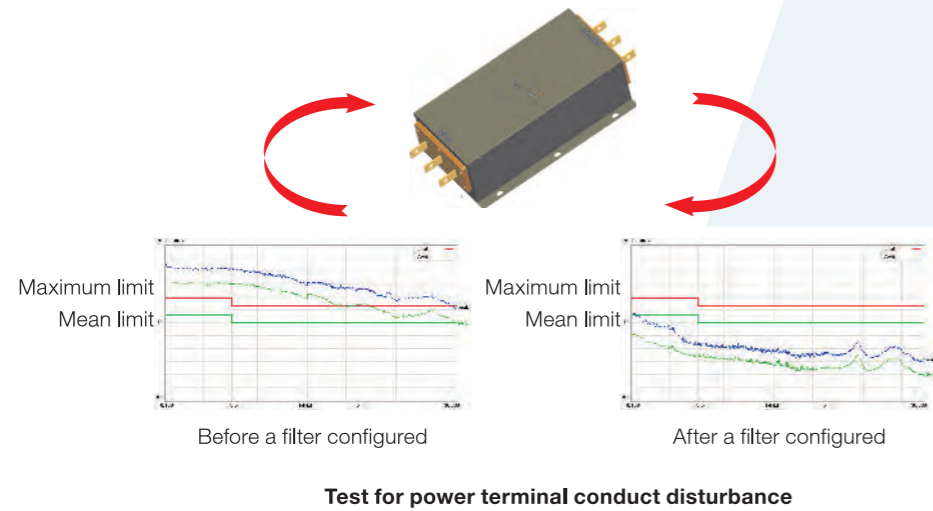

Note:
 C2 filters: EMC performance meets civilian environments.
 C3 filters: EMC performance meets industrial environments.

Abundant external interfaces, meeting the requirements of most application sites

Terminal type	Quantity	Feature
Digital input	4	1. Programmable multi-function terminal 2. Max. input frequency: 1 kHz 3. Compatible with both NPN and PNP inputs
High-speed pulse input	2	1. Max. input frequency: 50 kHz 2. Compatible with both NPN and PNP inputs 3. Supporting the input of quadrature encoders, and providing the speed detection function
Analog input	2	0~10V, 0~20mA, -10~-10V
Digital output	1	Max. output frequency: 1 kHz
High-speed pulse output	1	Max. output frequency: 50kHz
Analog output	2	0~10V, 0~20mA
Relay output	2	3A/AC250V, 1A/DC30V; NO+NC

Ease of use

Wireless commissioning

(1) Bluetooth/WIFI connection. You can use the mobile phone application to substitute for the traditional keypad.

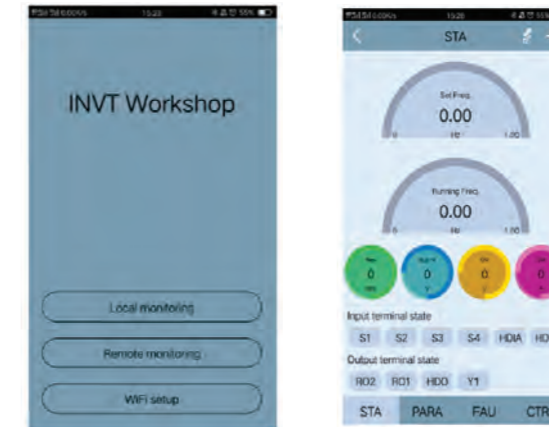

Connecting through the Internet of Things (IoT), remote monitoring

(1) Wireless access. You can easily connect to the IoT, operate the VFD through mobile phone or PC, and obtain the running state of the VFD in real time.

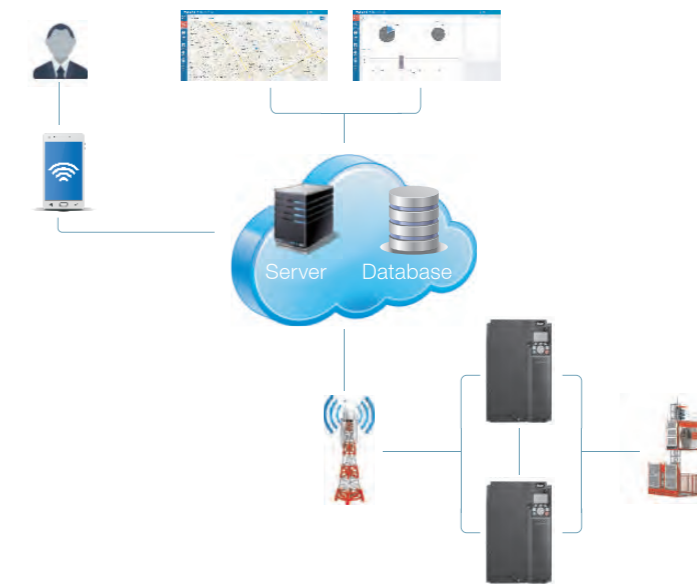

Standard USB interface

USB update
 Record the operation curve and failure waveform for easy mainstream and analysis.

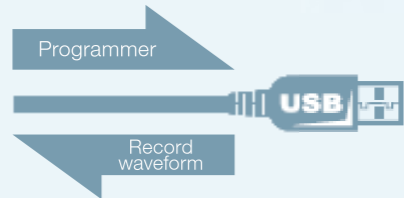

Providing the multi-function LCD operating panel, user-friendly design, focusing on user experience



No.	name	No.	name
1	Run	9	Running key
2	Trip	10	Stop/Reset key
3	Quick/Jog	11	Direction key
4	Function key	12	Display screen
5		13	RJ45 interface
6		14	Clock battery cover
7	Short-cut key	15	Mini USB terminal
8	Confirmation key		

Safe and reliable

Optimal reliability test system, ensuring that the product meets the most complicated application environments

INVT is the first manufacturer in China that has been awarded the Acceptance of Client Testing (ACT) accreditation (data accreditation) issued by TÜV SÜD, which means the technologies, test data, and test reports of INVT's labs are accepted by TÜV SÜD.

Providing the built-in safe torque off (STO) function, reaching the international level, ensuring more safe and reliable application

- (1) SIL2 level
- (2) Can be used to set up a safety system

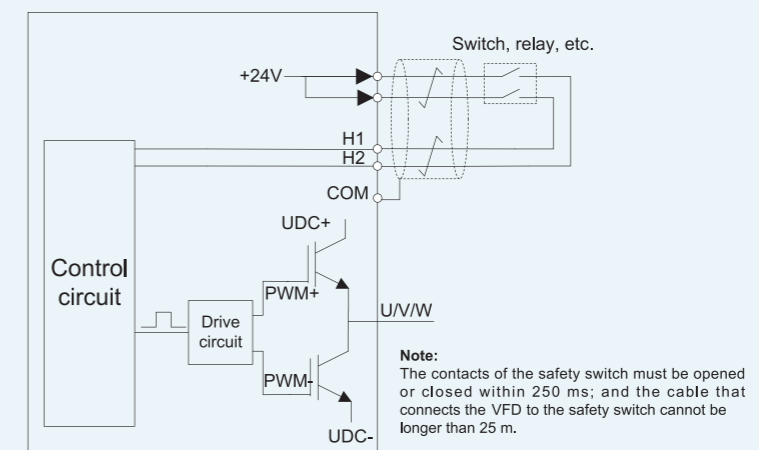

Application Scenarios

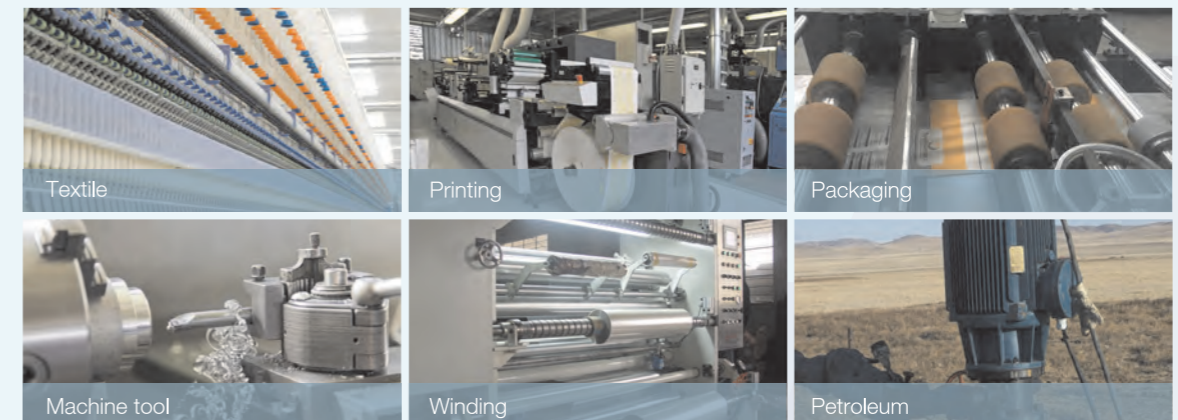

Technical Specification

Function description		Specification
Power input	Input voltage (V)	AC 3PH 380V (-15%)~440V (+10%) rated voltage: 380V AC 3PH 520V (-15%)~690V (+10%) rated voltage: 660V
	Input current (A)	Refer to <i>Rated value</i>
	Input frequency (Hz)	50Hz or 60Hz, allowable range: 47~63Hz
Power output	Output voltage (V)	0~input voltage
	Output current (A)	Refer to <i>Rated value</i>
	Output power (kW)	Refer to <i>Rated value</i>
	Output frequency (Hz)	0~400Hz
Technical Control performance	Control mode	SVPWM control, SVC, VC
	Motor type	Asynchronous motor, permanent-magnet synchronous motor
	Speed regulation ratio	Asynchronous motor 1: 200 (SVC); Synchronous motor 1 20 (SVC) , 1:1000 (VC)
	Speed control precision	±0.2% (SVC), ±0.02% (VC)
	Speed fluctuation	± 0.3% (SVC)
	Torque response	<20ms SVC) , <10ms (VC)
	Torque control precision	10% (SVC) , 5% (VC)
	Starting torque	Asynchronous motor: 0.25Hz/150% (SVC) Synchronous motor: 2.5 Hz/150% (SVC) 0Hz/200% (VC)
	Overload capacity	150% of rated current: 1min; 180% of rated current: 10s; 200% of rated current: 1s;
	Running control performance	Frequency setup mode
Automatic voltage regulation function		Keep the output voltage constant when grid voltage changes.
Fault protection function		Fault protection function Provide over 30 kinds of fault protection functions: overcurrent, overvoltage, under-voltage, over-temperature, phase loss and overload, etc.
Speed tracking restart function		Realize impact-free starting of the motor in rotating Note: This function is available for 4kW and above models
Peripheral Interface	Terminal analog input	No more than 20mV
	Terminal digital input resolution	No more than 2ms
	Analog input	2 inputs, AI1: 0~10V/0~20mA; AI2: -10~10V
	Analog output	1 output, AO1: 0~10V /0~20mA
	Digital input	Four regular inputs; Max. frequency: 1kHz; Internal impedance: 3.3kΩ Two high-speed inputs; Max. frequency: 50kHz; supports quadrature encoder input; Speed measurement function
	Digital output	One high-speed pulse output; max. frequency: 50kHz One Y terminal open collector output
	Relay output	Two programmable relay outputs RO1A NO, RO1B NC, RO1C common port RO2A NO, RO2B NC, RO2C common port Contact capacity: 3A/AC250V, 1A/DC30V
	Extension interface	Three extension interfaces: SLOT1, SLOT2, SLOT3 Expandable PG card, programmable extension card, communication card, I/O card, etc.

Function description		Specification
Others	Installation mode	Support wall-mounting, floor-mounting and flange-mounting
	Temperature of running environment	-10~50°C, derating is required if the ambient temperature exceeds 40°C
	Protection level	IP20
	Pollution level	Level 2
	Cooling mode	Air cooling
	Brake unit	Built-in brake unit for 380V 37kW and below models; Optional built-in brake unit for 380V 45kW~110kW(inclusive) models; Optional external brake unit for 660V models;
	EMC filter	380V models fulfill the requirements of IEC61800-3 C3 Optional external filter should meet the requirements of IEC61800-3 C2

Type Selection

GD350 - 5R5G - 4

① ② ③

Fig 3.6 Type designation key

Field	Sign	Description	Contents
Abbreviation of product series	①	Abbreviation of product series	GD350: Goodrive350 high-performance multi-function VFD
Rated power	②	Power range + load type	5R5-5.5kW G—Constant torque load
Voltage level	③	Voltage level	4: AC 3PH 380V (-15%)~440V (+10%) Rated voltage: 380V 6: AC 3PH 520V (-15%)~690V (+10%) Rated voltage: 660V

Power ratings and dimension

VFD model	Rated output power (kW)	Input current (A)	Rated output current (A)	Net/Gross weight (kg)	Dimension (mm)
AC 3PH 380V(-15%)~440V(+10%)					
GD350-1R5G-4	1.5	5.0	3.7	2/3	126*186*185
GD350-2R2G-4	2.2	5.8	5		
GD350-004G-4	4	13.5	9.5	2.5/3.5	126*186*201
GD350-5R5G-4	5.5	19.5	14		
GD350-7R5G-4	7.5	25	18.5	3/4	146*256*192
GD350-011G-4	11	32	25		
GD350-015G-4	15	40	32		
				6/7	170*320*220

VFD model	Rated output power (kW)	Input current (A)	Rated output current (A)	Net/Gross weight (kg)	Dimension (mm)
AC 3PH 380V(-15%)-440V(+10%)					
GD350-018G-4	18.5	47	38	8.5/10.5	200*340.6*208
GD350-022G-4	22	51	45		
GD350-030G-4	30	70	60	16/17	250*400*223
GD350-037G-4	37	80	75		
GD350-045G-4	45	98	92	25/29	282*560*258
GD350-055G-4	55	128	115		
GD350-075G-4	75	139	150		
GD350-090G-4	90	168	180	41/52	338*554*330
GD350-110G-4	110	201	215		
GD350-132G-4	132	265	260	85/110	500*870*360
GD350-160G-4	160	310	305		
GD350-185G-4	185	345	340		
GD350-200G-4	200	385	380		
GD350-220G-4	220	430	425	135/165	680*960*380
GD350-250G-4	250	460	480		
GD350-280G-4	280	500	530		
GD350-315G-4	315	580	600	350/407	620*1700*560
GD350-355G-4	355	625	650		
GD350-400G-4	400	715	720		
GD350-500G-4	500	890	860		
AC 3PH 520V(-15%)-690V(+10%)					
GD350-022G-6	22	35	27	30/32	270*555*325
GD350-030G-6	30	40	34		
GD350-370G-6	37	47	42		
GD350-045G-6	45	52	54	47/67	325*680*365
GD350-055G-6	55	65	62		
GD350-075G-6	75	85	86		
GD350-090G-6	90	95	95	85/110	500*870*360
GD350-110G-6	110	118	131		
GD350-132G-6	132	145	147		
GD350-160G-6	160	165	163	85/110	500*870*360
GD350-185G-6	185	190	198		
GD350-200G-6	200	210	216		
GD350-220G-6	220	230	240	135/165	680*960*380
GD350-250G-6	250	255	274		
GD350-280G-6	280	286	300		
GD350-315G-6	315	334	328		
GD350-355G-6	355	360	380		

GD350-400G-6	400	411	426	350/407	620*1700*560
GD350-450G-6	450	445	465		
GD350-500G-6	500	518	540		
GD350-560G-6	560	578	600		
GD350-630G-6	630	655	688		

Installation Dimension

Wall mounting installation diagram

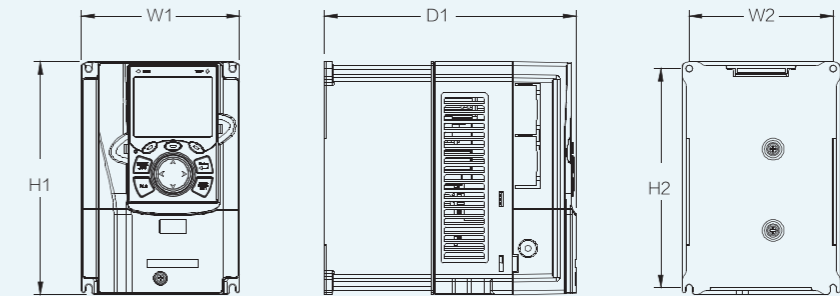

380V, 1.5-37kW

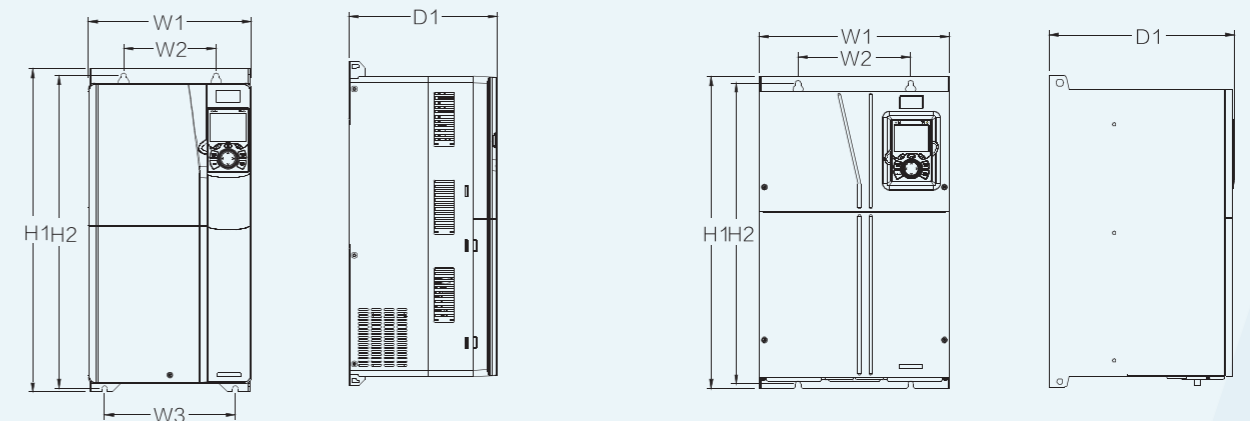

380V, 45-75kW

380V, 90-110kW

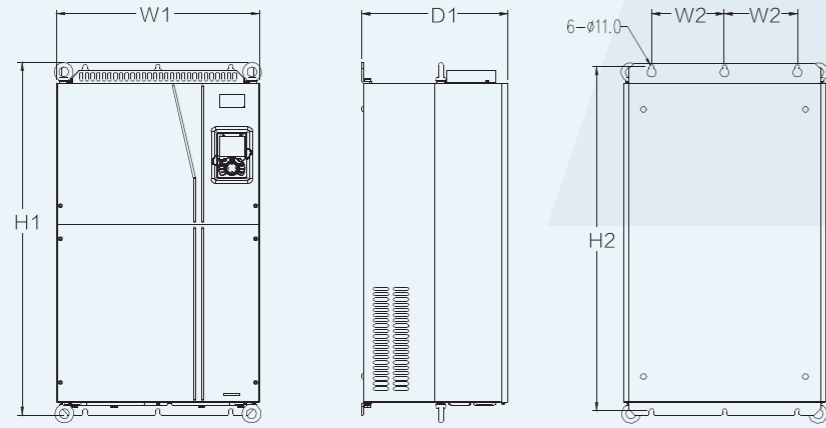

660V, 160~220kW

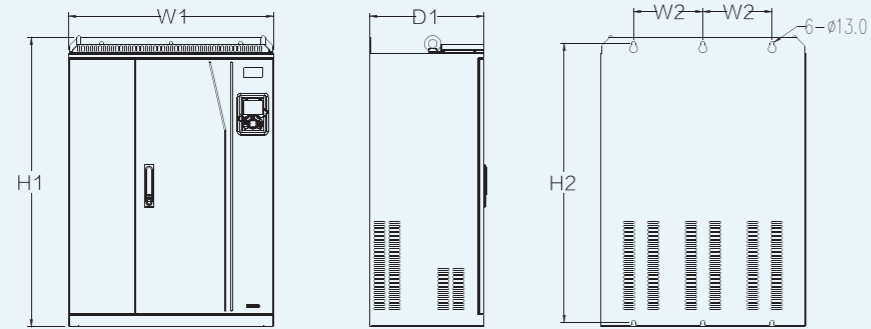

660V, 250~355kW

Flange mounting installation diagram

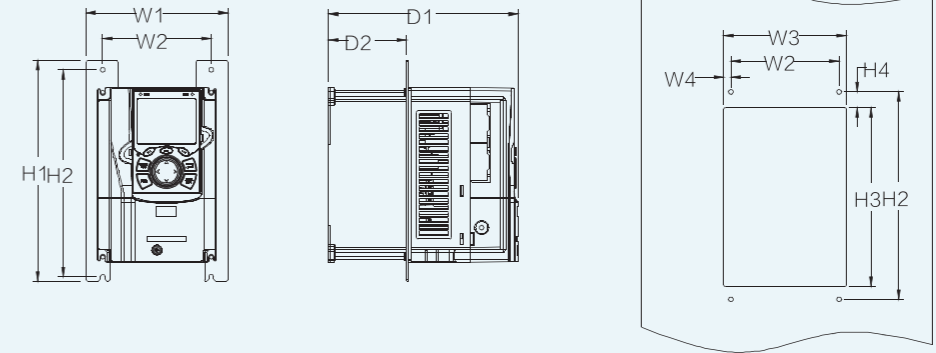

380V, 1.5~75kW

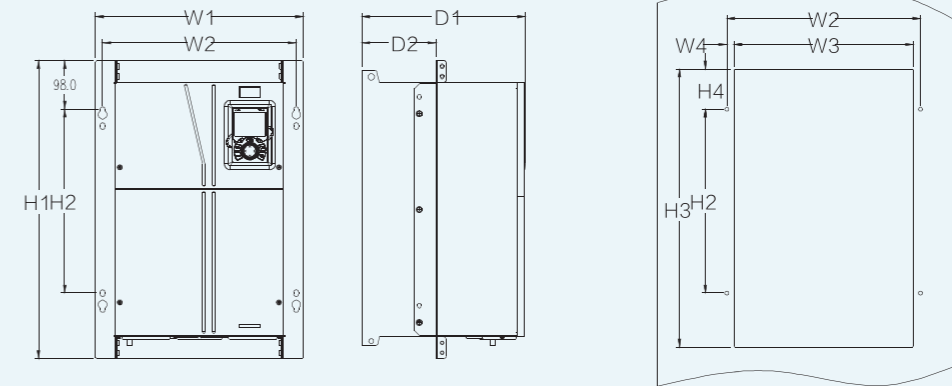

380V, 90~110kW

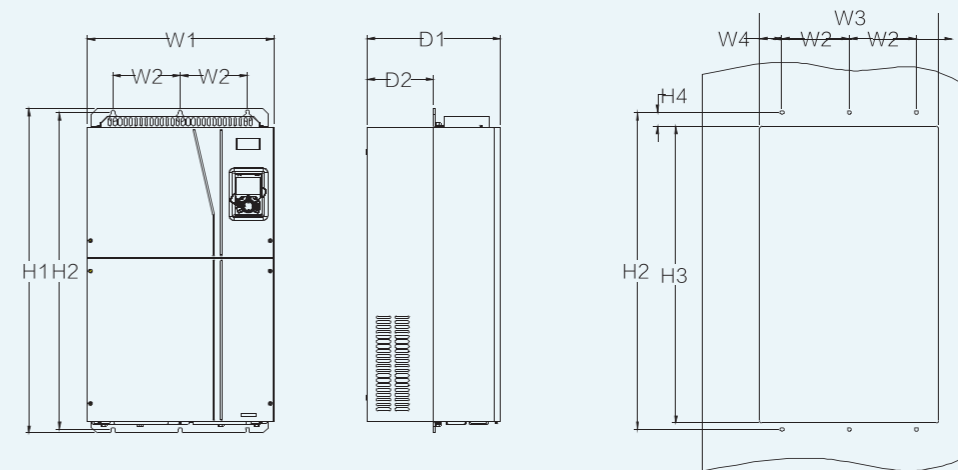

380V, 132~220kW

Model	W1	W2	W3	H1	H2	D1	Installation hole diameter	Fixing screw	
380	1.5kW~2.2kW	126	115	-	186	175	185	5	M4
	4kW~5.5kW	126	115	-	186	175	201	5	M4
	7.5kW	146	131	-	256	243.5	192	6	M5
	11kW~15kW	170	151	-	320	303.5	220	6	M5
	18.5kW~22kW	200	185	-	340.6	328.6	208	6	M5
	30kW~37kW	250	230	-	400	380	223	6	M5
	45kW~75kW	282	160	226	560	542	258	9	M8
	90kW~110kW	338	200	-	554	535	330	10	M8
	132kW~200kW	500	180	-	870	850	360	11	M10
220kW~315kW	680	230	-	960	926	380	13	M12	
660V	22kW~45kW	270	130	-	555	540	325	7	M6
	55kW~132kW	325	200	-	680	661	365	9.5	M8
	160kW~220kW	500	180	-	870	850	360	11	M10
	250kW~355kW	680	230	-	960	926	380	13	M12

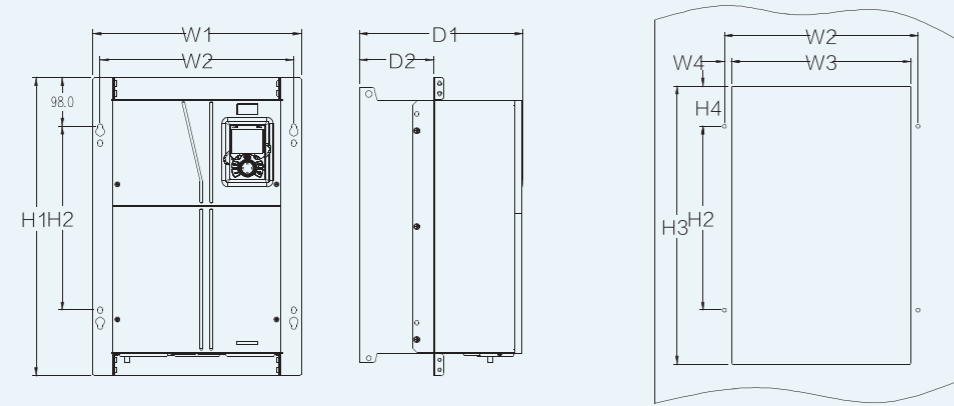

660V, 22~132kW

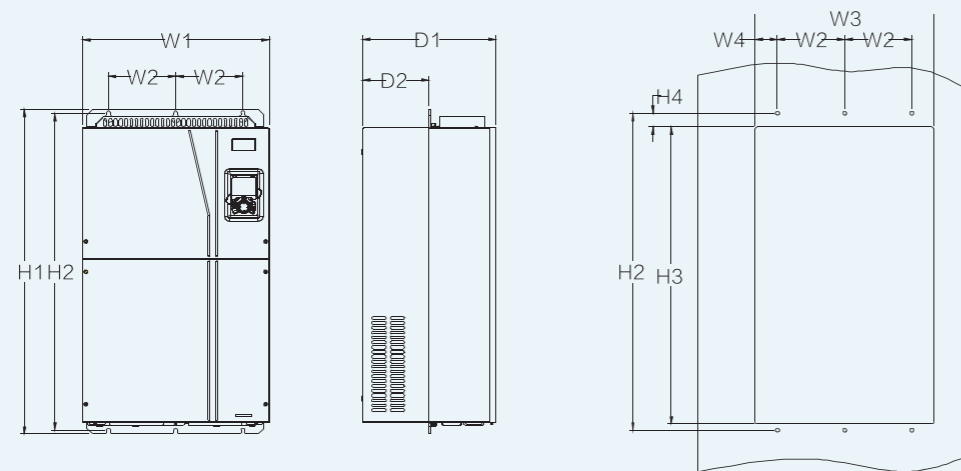

600V, 160~220kW

	Model	W1	W2	W3	W4	H1	H2	H3	H4	D1	D2	Installation hole diameter	Fixing screw
380V	1.5kW~2.2kW	150.2	115	130	7.5	234	220	190	13.5	185	65.5	5	M4
	4kW~5.5kW	150.2	115	130	7.5	234	220	190	13.5	201	83	5	M4
	7.5kW	170.2	131	150	9.5	292	276	260	6	192	84.5	6	M5
	11kW~15kW	191.2	151	174	11.5	370	351	324	12	220	113	6	M5
	18.5kW~22kW	266	250	224	13	371	250	350.6	20.3	208	104	6	M5
	30kW~37kW	316	300	274	13	430	300	410	55	223	118.3	6	M5
	45kW~75kW	352	332	306	12	580	400	570	80	258	133.8	9	M8
	90kW~110kW	418.5	389.5	361	14.2	600	370	559	108.5	330	149.5	10	M8
	132kW~200kW	500	180	480	60	870	850	796	37	360	178.5	11	M10
660V	22kW~45kW	270	130	261	65.5	555	540	56	17	325	167	7	M6
	55kW~132kW	325	200	317	58.5	680	661	626	23	363	182	9.5	M8
	160kW~220kW	500	180	480	60	870	850	796	37	358	178.5	11	M10

Floor mounting installation diagram

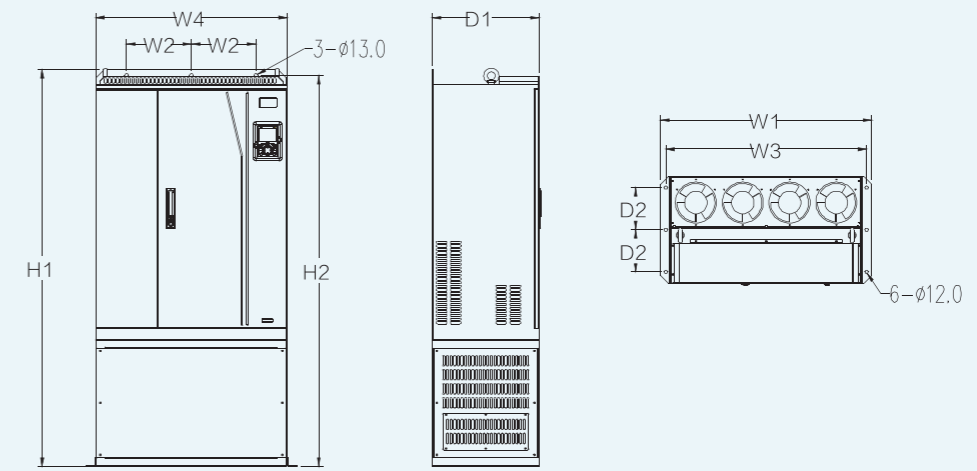

380V, 220~315kW

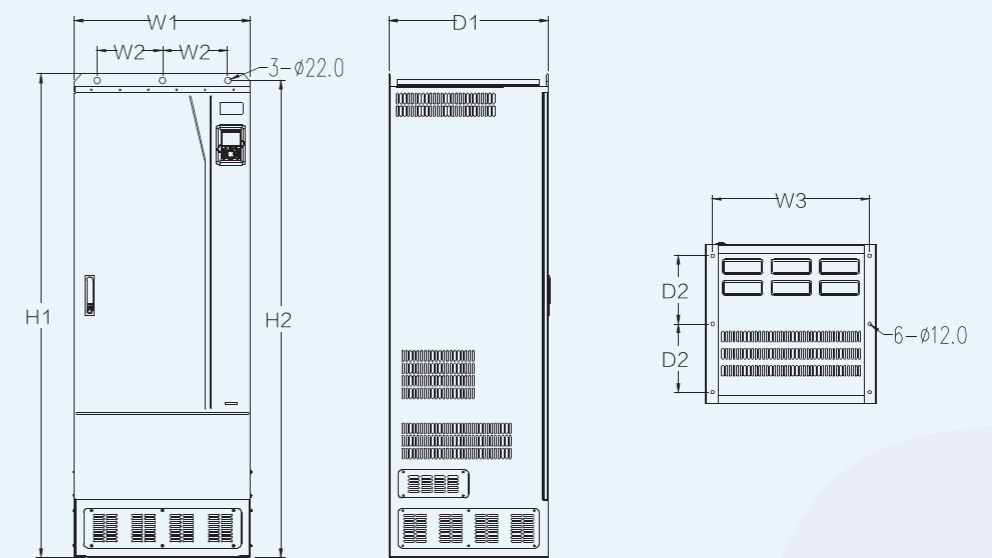

380V, 355~500kW

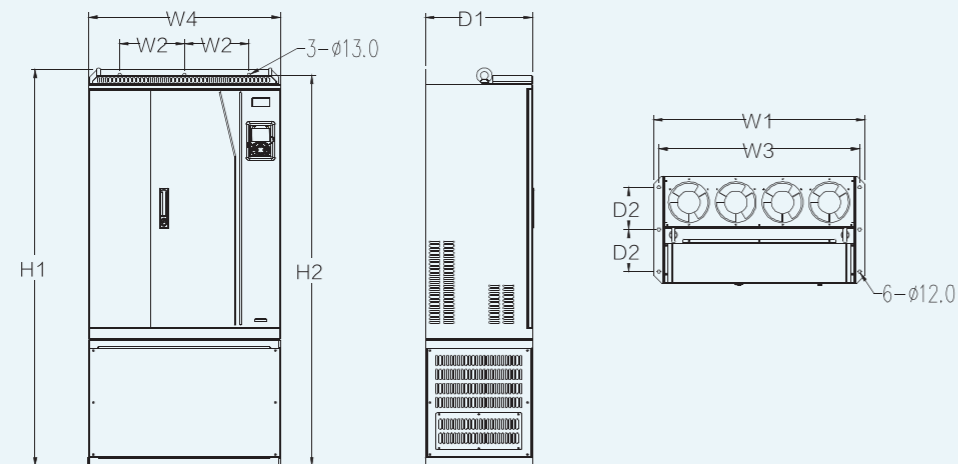

660V, 250~355kW

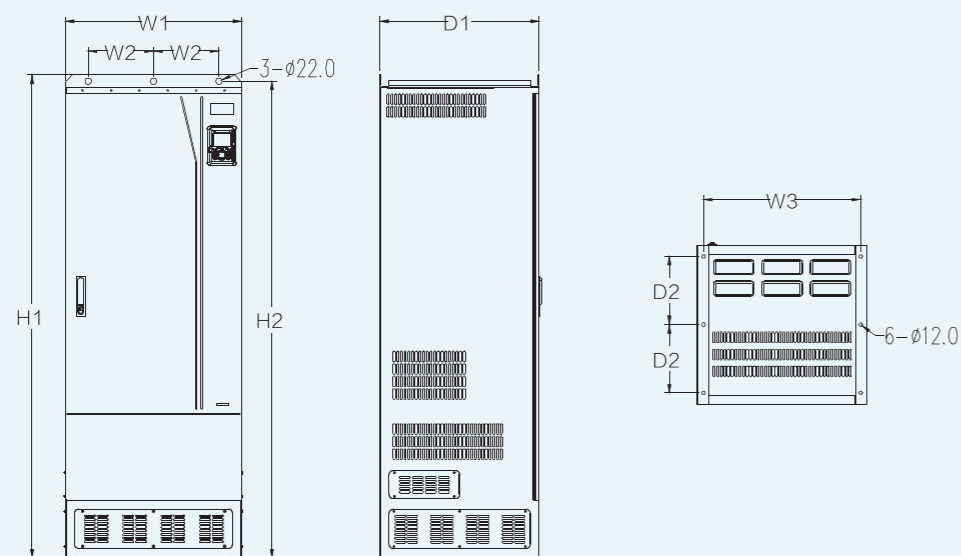

660V, 400~630kW

Model		W1	W2	W3	W4	H1	H2	D1	D2	Installation hole diameter	Fixing screw
380V	220kW~315kW	750	230	714	680	1410	1390	380	150	13\12	M12/M10
	355kW~500kW	620	230	572	-	1700	1678	560	240	22\12	M20/M10
660V	250kW~355kW	750	230	714	680	1410	1390	380	150	13\12	M12/M10
	400kW~630kW	620	230	572	\	1700	1678	560	240	22\12	M20/M10

Optional Parts

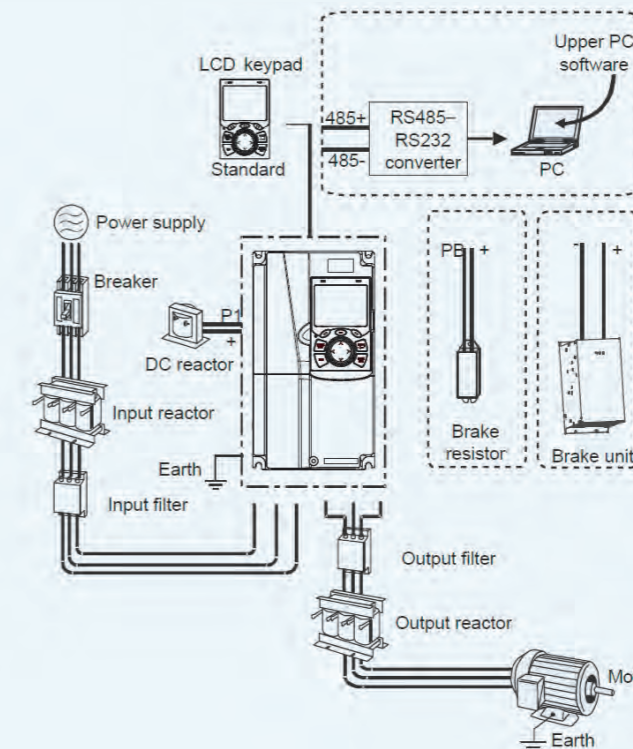

- VFDs of 380V, 37 kW or lower are equipped with built-in brake units, and VFDs of 45 kW to 110 kW can be configured with optional built-in brake units
- VFDs of 380 V, 18.5 kW to 110 kW are equipped with built-in DC reactors
- P1 terminals are equipped only for VFDs of 380 V, 132 kW or higher, which enable the VFDs to be directly connected to external DC reactors
- P1 terminals are equipped for all VFDs of the 660 V series or higher, which enable the VFDs to be directly connected to external DC reactors
- The brake units INVT's DBU series standard brake units. For details, see the DBU operation manual

Breakers and electromagnetic contactors

Model	Fuse (A)	Breaker (A)	Rated current of the contactor (A)	
380V	GD350-1R5G-4	1	16	10
	GD350-2R2G-4	17.4	16	10
	GD350-004G-4	30	25	16
	GD350-5R5G-4	45	25	16
	GD350-7R5G-4	60	40	25
	GD350-011G-4	78	63	32
	GD350-015G-4	105	63	50
GD350-018G-4	114	100	63	

	Model	Fuse (A)	Breaker (A)	Rated current of the contactor (A)
380V	GD350-022G-4	138	100	80
	GD350-030G-4	186	125	95
	GD350-037G-4	228	160	120
	GD350-045G-4	270	200	135
	GD350-055G-4	315	200	170
	GD350-075G-4	420	250	230
	GD350-090G-4	480	315	280
	GD350-110G-4	630	400	315
	GD350-132G-4	720	400	380
	GD350-160G-4	870	630	450
	GD350-185G-4	1110	630	580
	GD350-200G-4	1110	630	580
	GD350-220G-4	1230	800	630
	GD350-250G-4	1380	800	700
	GD350-280G-4	1500	1000	780
	GD350-315G-4	1740	1200	900
GD350-355G-4	1860	1280	960	
GD350-400G-4	2010	1380	1035	
GD350-450G-4	2445	1630	1222	
GD350-500G-4	2505	1720	1290	
660V	GD350-022G-6	105	63	50
	GD350-030G-6	105	63	50
	GD350-370G-6	114	100	63
	GD350-045G-6	138	100	80
	GD350-055G-6	186	125	95
	GD350-075G-6	270	200	135
	GD350-090G-6	270	200	135
	GD350-110G-6	315	200	170
	GD350-132G-6	420	250	230
	GD350-160G-6	480	315	280
	GD350-185G-6	480	315	280
	GD350-200G-6	630	400	315
	GD350-220G-6	720	400	380
	GD350-250G-6	720	400	380
	GD350-280G-6	870	630	450
	GD350-315G-6	1110	630	580
GD350-355G-6	1110	630	580	

	Model	Fuse (A)	Breaker (A)	Rated current of the contactor (A)
660V	GD350-400G-6	1230	800	630
	GD350-450G-6	1470	960	735
	GD350-500G-6	1500	100	780
	GD350-560G-6	1740	1200	900
	GD350-630G-6	2010	1380	1035

Reactors

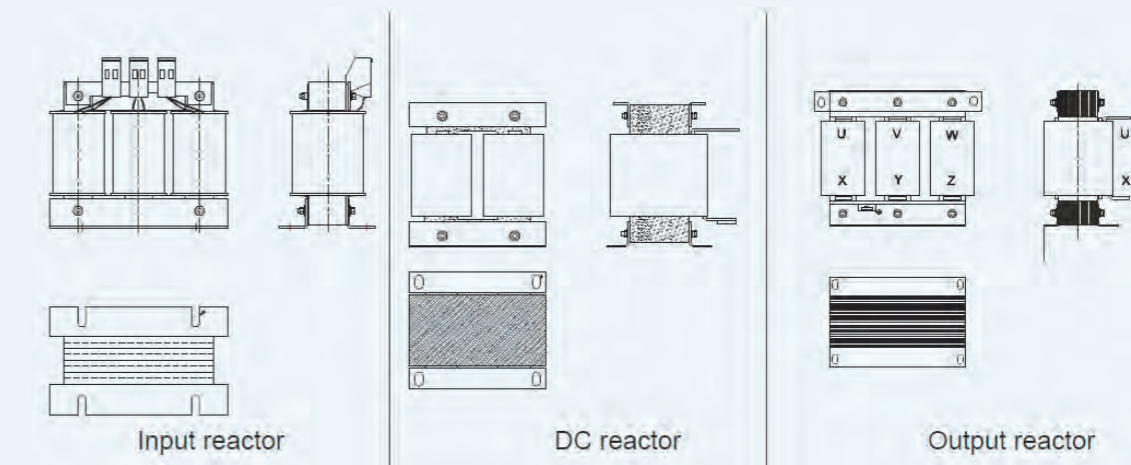

	Model	Input reactor	DC reactor	Output reactor
380V	GD350-1R5G-4	ACL2-1R5G-4	/	OCL2-1R5G-4
	GD350-2R2G-4	ACL2-2R2G-4		OCL2-2R2G-4
	GD350-004G-4	ACL2-004G-4		OCL2-004G-4
	GD350-5R5G-4	ACL2-5R5G-4		OCL2-5R5G-4
	GD350-7R5G-4	ACL2-7R5G-4		OCL2-7R5G-4
	GD350-011G-4	ACL2-011G-4		OCL2-011G-4
	GD350-015G-4	ACL2-015G-4		OCL2-015G-4
	GD350-018G-4	ACL2-018G-4		OCL2-018G-4
	GD350-022G-4	ACL2-022G-4	Standard Built-in	OCL2-022G-4
	GD350-030G-4	ACL2-030G-4		OCL2-030G-4
	GD350-037G-4	ACL2-037G-4		OCL2-037G-4
	GD350-045G-4	ACL2-045G-4		OCL2-045G-4
	GD350-055G-4	ACL2-055G-4		OCL2-055G-4
	GD350-075G-4	ACL2-075G-4		OCL2-075G-4
	GD350-090G-4	ACL2-090G-4		OCL2-090G-4
	GD350-110G-4	ACL2-110G-4		OCL2-110G-4
GD350-132G-4	ACL2-132G-4	DCL2-132-4	OCL2-132G-4	

	Model	Input reactor	DC reactor	Output reactor
380V	GD350-160G-4	ACL2-160G-4	DCL2-160-4	OCL2-160G-4
	GD350-185G-4	ACL2-185G-4	DCL2-185-4	OCL2-185G-4
	GD350-200G-4	ACL2-200G-4	DCL2-200-4	OCL2-200G-4
	GD350-220G-4	ACL2-220G-4	DCL2-220-4	OCL2-220G-4
	GD350-250G-4	ACL2-250G-4	DCL2-250-4	OCL2-250G-4
	GD350-280G-4	ACL2-280G-4	DCL2-280-4	OCL2-280G-4
	GD350-315G-4	ACL2-315G-4	DCL2-315-4	OCL2-315G-4
	GD350-355G-4	Standard Built-in	DCL2-400-4	OCL2-350G-4
	GD350-400G-4		DCL2-400-4	OCL2-400G-4
	GD350-450G-4		DCL2-500-4	OCL2-500G-4
GD350-500G-4	DCL2-500-4		OCL2-500G-4	
660V	GD350-022G-6	ACL2-022G-6	DCL2-022G-6	OCL2-022G-6
	GD350-030G-6	ACL2-030G-6	DCL2-030G-6	OCL2-030G-6
	GD350-370G-6	ACL2-370G-6	DCL2-037G-6	OCL2-037G-6
	GD350-045G-6	ACL2-045G-6	DCL2-045G-6	OCL2-045G-6
	GD350-055G-6	ACL2-055G-6	DCL2-055G-6	OCL2-055G-6
	GD350-075G-6	ACL2-075G-6	DCL2-075G-6	OCL2-075G-6
	GD350-090G-6	ACL2-090G-6	DCL2-090G-6	OCL2-090G-6
	GD350-110G-6	ACL2-110G-6	DCL2-110G-6	OCL2-110G-6
	GD350-132G-6	ACL2-132G-6	DCL2-132G-6	OCL2-132G-6
	GD350-160G-6	ACL2-160G-6	DCL2-160G-6	OCL2-160G-6
	GD350-185G-6	ACL2-185G-6	DCL2-185G-6	OCL2-185G-6
	GD350-200G-6	ACL2-200G-6	DCL2-200G-6	OCL2-200G-6
	GD350-220G-6	ACL2-220G-6	DCL2-220G-6	OCL2-220G-6
	GD350-250G-6	ACL2-250G-6	DCL2-250G-6	OCL2-250G-6
	GD350-280G-6	ACL2-280G-6	DCL2-280G-6	OCL2-280G-6
	GD350-315G-6	ACL2-315G-6	DCL2-315G-6	OCL2-315G-6
	GD350-355G-6	ACL2-350G-6	DCL2-350G-6	OCL2-350G-6
	GD350-400G-6	Standard Built-in	DCL2-400G-6	OCL2-400G-6
	GD350-450G-6		DCL2-500G-6	OCL2-500G-6
	GD350-500G-6		DCL2-500G-6	OCL2-500G-6
GD350-560G-6	DCL2-560G-6		OCL2-560G-6	
GD350-630G-6	DCL2-630G-6		OCL2-630G-6	

Filters

FLT-P 04 045 L-B

A B C D E F

Filter identifier	Field description
A	FLT: Name of the VFD filter series
B	Filter type P: Power input filter L: Output filter
C	Voltage class 04: AC 3PH 380V (-15%)~440V (+10%) 06: AC 3PH 520V (-15%)~690V (+10%)
D	3-digit code indicating the rated current. For example, 015 indicates 15A.
E	Filter performance L: General H: High-performance
F	Filter application environment A: Environment Category I, C1 (EN 61800-3:2004) B: Environment Category I, C2 (EN 61800-3:2004) C: Environment Category II, C3 (EN 61800-3:2004)

VFD model	Input filter	Output filter
AC 3PH 380V (-15%)~440V (+10%)		
GD350-1R5G-4	FLT-P04006L-B	FLT-P04006L-B
GD350-2R2G-4		
GD350-004G-4	FLT-P04016L-B	FLT-P04016L-B
GD350-5R5G-4		
GD350-7R5G-4	FLT-P04032L-B	FLT-P04032L-B
GD350-011G-4		
GD350-015G-4	FLT-P04045L-B	FLT-P04045L-B
GD350-018G-4		
GD350-022G-4	FLT-P04065L-B	FLT-P04065L-B
GD350-030G-4		
GD350-037G-4	FLT-P04100L-B	FLT-P04100L-B
GD350-045G-4		
GD350-055G-4	FLT-P04150L-B	FLT-P04150L-B
GD350-075G-4		
GD350-090G-4	FLT-P04240L-B	FLT-P04240L-B
GD350-110G-4		
GD350-132G-4		
GD350-160G-4	FLT-P04400L-B	FLT-P04400L-B
GD350-185G-4		
GD350-200G-4		

VFD model	Input filter	Output filter
AC 3PH 380V (-15%)–440V (+10%)		
GD350-220G-4	FLT-P04600L-B	FLT-P04600L-B
GD350-250G-4		
GD350-280G-4		
GD350-315G-4	FLT-P04800L-B	FLT-P04800L-B
GD350-355G-4		
GD350-400G-4		
GD350-450G-4	FLT-P041000L-B	FLT-P041000L-B
GD350-500G-4		
AC 3PH 520V (-15%) – 690V (+10%)		
GD350-022G-6	FLT-P06050H-B	FLT-P06050H-B
GD350-030G-6		
GD350-370G-6		
GD350-045G-6	FLT-P06100H-B	FLT-P06100H-B
GD350-055G-6		
GD350-075G-6		
GD350-090G-6		
GD350-110G-6	FLT-P06200H-B	FLT-P06200H-B
GD350-132G-6		
GD350-160G-6		
GD350-185G-6		
GD350-200G-6	FLT-P06300H-B	FLT-P06300H-B
GD350-220G-6		
GD350-250G-6		
GD350-280G-6		
GD350-315G-6	FLT-P06400H-B	FLT-P06400H-B
GD350-355G-6		
GD350-400G-6	FLT-P061000H-B	FLT-P061000H-B
GD350-450G-6		
GD350-500G-6		
GD350-560G-6		
GD350-630G-6		

Brake system

VFD model	Brake unit model	Resistance applicable for brake torque (Ω)	Dissipated power of brake resistor (kW)			Min. allowable brake resistor (Ω)	
			10% brake usage	50% brake usage	80% brake usage		
AC 3PH 380V (-15%)–440V (+10%)							
GD350-1R5G-4	Standard Built-in	326	0.23	1.1	1.8	170	
GD350-2R2G-4		222	0.33	1.7	2.6	130	
GD350-004G-4		122	0.6	3	4.8	80	
GD350-5R5G-4		89	0.75	4.1	6.6	60	
GD350-7R5G-4		65	1.1	5.6	9	47	
GD350-011G-4		44	1.7	8.3	13.2	31	
GD350-015G-4		32	2	11	18	23	
GD350-018G-4		27	3	14	22	19	
GD350-022G-4		22	3	17	26	17	
GD350-030G-4		17	5	23	36	17	
GD350-037G-4		13	6	28	44	11.7	
GD350-045G-4		DBU100H-110-4	10	7	34	54	6.4
GD350-055G-4			8	8	41	66	
GD350-075G-4	DBU100H-160-4	6.5	11	56	90	4.4	
GD350-090G-4		5.4	14	68	108		
GD350-110G-4	DBU100H-220-4	4.5	17	83	132	3.2	
GD350-132G-4		3.7	20	99	158		
GD350-160G-4	DBU100H-320-4	3.1	24	120	192	2.2	
GD350-185G-4		2.8	28	139	222		
GD350-200G-4	DBU100H-400-4	2.5	30	150	240	1.8	
GD350-220G-4		2.2	33	165	264		
GD350-250G-4	Two sets	2.0	38	188	300	2.2*2	
GD350-280G-4		3.6*2	21*1	105*2	168*2		
GD350-315G-4		3.2*2	24*2	118*2	189*2		
GD350-355G-4	DBU100H-320-4	2.8*2	27*2	132*2	210*2	1.8*2	
GD350-400G-4		2.4*2	30*2	150*2	240*2		
GD350-450G-4	Two sets	2.2*2	34*2	168*2	270*2	1.8*2	
GD350-500G-4		2.0*2	38*2	186*2	300*2		

VFD model	Brake unit model	Resistance applicable for brake torque (Ω)	Dissipated power of brake resistor (kW)			Min. allowable brake resistor (Ω)
			10% brake usage	50% brake usage	80% brake usage	
AC 3PH 520V (-15%)~690V (+10%)						
GD350-022G-6	DBU100H-110-6	55	4	17	27	10.0
GD350-030G-6		40.3	5	23	36	
GD350-370G-6		32.7	6	28	44	
GD350-045G-6		26.9	7	34	54	
GD350-055G-6		22.0	8	41	66	
GD350-075G-6		16.1	11	56	90	
GD350-090G-6		13.4	14	68	108	
GD350-110G-6		11.0	17	83	132	
GD350-132G-6	DBU100H-160-6	9.2	20	99	158	6.9
GD350-160G-6		7.6	24	120	192	
GD350-185G-6	DBU100H-220-6	6.5	28	139	222	5.0
GD350-200G-6		6.1	30	150	240	
GD350-220G-6	DBU100H-320-6	5.5	33	165	264	3.4
GD350-250G-6		4.8	38	188	300	
GD350-280G-6		4.3	42	210	336	
GD350-315G-6		3.8	47	236	378	
GD350-355G-6	DBU100H-400-6	3.5	53	263	420	2.8
GD350-400G-6		3.0	60	300	480	
GD350-450G-6	Two sets	5.5*2	34*2	168*2	270*2	3.4*2
GD350-500G-6		4.8*2	38*2	188*2	300*2	
GD350-560G-6	DBU100H-320-6	4.3*2	42*2	210*2	336*2	3.4*2
GD350-630G-6		3.8*2	47*2	236*2	378*2	

Extension cards

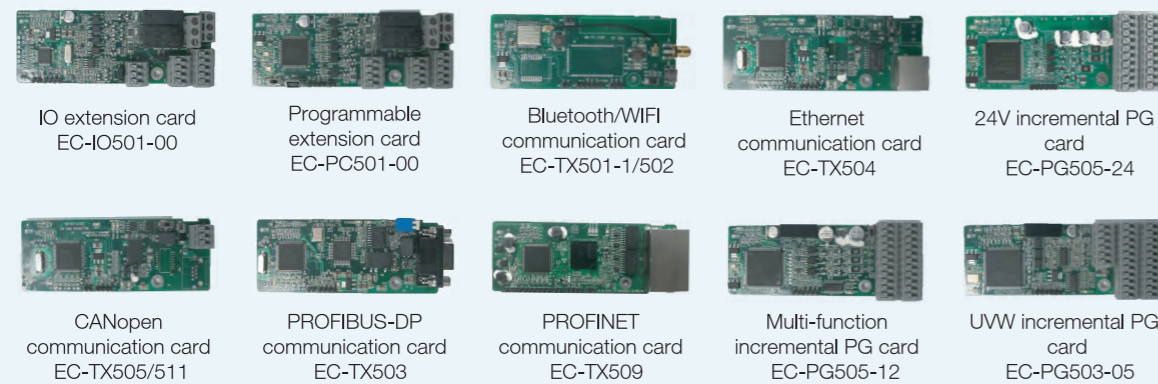

Type	Name	model	Specification
I/O card	IO extension card	EC-IO501-00	4 channels switch input 1 channel switch output 1 channel analog input 1 channel analog output 2 channels relay output.
PLC card	Programmable extension card	EC-PC501-00	6 channels switch input 2 channels switch output 2 channels relay output.
Communication card	Bluetooth communication card	EC-TX501-1 EC-TX501-2	Support Bluetooth 4.0 PCB antenna type or external sucker antenna. Effective communication distance is 30m.
	CANopen communication card	EC-TX505	Based on the CAN2.0A physical layer Support the CANopen protocol.
	PROFIBUS-DP communication card	EC-TX503	Support PZB to control data exchange. Support PZW to access VFD parameters. Baud rate supports up to 12Mbps.
	WIFI communication card	EC-TX502-1 EC-TX502-2	Monitor the VFD locally or remotely through WIFI with INVT's mobile phone APP Effective communication distance is 30m.
	Ethernet communication card	EC-TX504	Support Ethernet communication with INVT's internal protocol INVT Studio
	CAN master/slave control communication card	EC-TX511	Based on the CAN2.0B physical layer Adopt INVT's master-slave control proprietary protocol
	PROFINET communication card	EC-TX509	Support the PROFINET protocol
PG card	Multi-function incremental PG card	EC-PG505-12	Applicable to OC encoders of 5 V or 12 V Applicable to push-pull encoders of 5 V or 12 V Applicable to differential encoders of 5 V Supporting pulse string setting
	UWV incremental PG card	EC-PG503-05	Encoder interface: 5V incremental differential ABZ(UWV) encoder, maximum 400kHz.
	Resolver PG card	EC-PG504-00	Rotary transformer encoder. support / directional differential input of pulse. support 5V differential signal 1-255 frequency division output, up to 200kHz
	24V incremental PG card	EC-PG505-24	Support A, B, Z orthogonal input Support A, B, Z frequency-divided output Support pulse string reference input
	Sin/Cos PG card	EG-PG502	Applicable to Sin/Cos encoders with or without CD signal Support A, B, Z frequency-divided output Support pulse string reference input
Incremental PG card	EC-PG507-12	Applicable to OC encoders of 5 V or 12 V Applicable to push-pull encoders of 5 V or 12 V Applicable to differential encoders of 5 V	

GD350 IP54 Series VFD

Introduction

Goodrive350 IP54 series VFDs provide the same control methods and extended functions as GD350. Some can be configured with optional built-in DC reactors as required by customers. The full-sheet metal structure is adopted. They support wall-mounting and flange installation. LCD keypads are the standard configuration. They are especially applicable in scenarios with harsh dust and water vapor conditions, such as those with HVAC, fans and pumps, stone, and wood.



Features:

- Ingress protection rating of IP54, applicable to working environments with harsh dust and water vapor conditions(Same as NAME 3S).
- Supporting both heavy and light loads, integrated G and P types.
- Reserving interfaces for implementing the real-time clock function.
- Supporting optional built-in DC reactors (18.5kW~110kW).
- Built-in brake resistors (1.5kW~37kW).

Level of protection—IP54



Built-in accessories

- Supporting built-in brake units(1.5~37kW), reducing customers' costs and installation space
- Providing built-in DC reactors for models of 18.5 kW~110 kW

Technical Specification

Function description		Specification
Technical control performance	Control mode	SVPWM control, SVC, VC
	Motor type	Asynchronous motor, permanent-magnet synchronous motor
	Speed regulation ratio	Asynchronous motor 1: 200 (SVC); Synchronous motor 1:20 (SVC) , 1:1000 (VC)
	Speed control precision	±0.2% (SVC), ±0.02% (VC)
	Speed fluctuation	± 0.3% (SVC)
	Torque response	<20ms (SVC) , <10ms (VC)
	Torque control precision	10% (SVC) , 5% (VC)
	Starting torque	Asynchronous motor: 0.25Hz/150% (SVC) Synchronous motor: 2.5 Hz/150% (SVC) 0Hz/200% (VC)
	Overload capacity	150% of rated current: 1min;180% of rated current: 10s;200% of rated current: 1s;
Running control performance	Frequency setup mode	Digital, analog, pulse frequency, multi-step speed running, simple PLC, PID, MODBUS communication, PROFIBUS communication, etc.; Realize switch-over between the set combination and the set channel
	Automatic voltage Regulation function	Keep the output voltage constant when grid voltage changes
	Fault protection function	Fault protection function Provide over 30 kinds of fault protection functions: overcurrent, overvoltage, undervoltage, over-temperature, phase loss and overload, etc.
	Speed tracking restart function	Realize impact-free starting of the motor in rotating Note: This function is available for 4kW and above models
Peripheral interface	Terminal analog input resolution	No more than 20mV
	Terminal digital input resolution	No more than 2ms
	Analog input	2 inputs, AI1: 0~10V/0~20mA; AI2: -10~10V
	Analog output	1 output, AO1: 0~10V /0~20mA

Function description		Specification
Peripheral interface	Digital input	Four regular inputs; max. frequency: 1kHz; internal impedance: 3.3kΩ Two high-speed inputs; max. frequency: 50kHz; supports quadrature encoder input; with speed measurement function
	Digital output	One high-speed pulse output; max. frequency: 50kHz One Y terminal open collector output
	Relay output	Two programmable relay outputs RO1A NO, RO1B NC, RO1C common port RO2A NO, RO2B NC, RO2C common port Contact capacity: 3A/AC250V, 1A/DC30V
	Extension interface	Three extension interfaces: SLOT1, SLOT2, SLOT3 Expandable PG card, programmable extension card, communication card, I/O card, etc
Others	Installation mode	Support wall-mounting and flange-mounting
	Temperature of running environment	-10~50°C, derating is required if the ambient temperature exceeds 40°C
	Protection level	IP54(3S in NAME)
	Pollution level	Level 3
	Cooling mode	Air cooling
	Brake unit	Built-in brake unit for 380V 1.5kW~37kW
	DC reactor	Built-in options in 18.5kW~110kW
EMC filter	380V models fulfill the requirements of IEC61800-3 C3 Optional external filter should meet the requirements of IEC61800-3 C2	

AC 3PH 380V(-15%)-440V(+10%) rated value

Product model	Output power (kW)	Input current (A)	Output current (A)	Gross weight (kg)	Dimension (mm)
GD350-004G/5R5P-45	4	13.5	9.5	17.7	196*296*212
GD350-5R5G/7R5P-45	5.5	19.5	14		
GD350-7R5G/011P-45	7.5	25	18.5	10.6	256*328*212
GD350-011G/015P-45	11	32	25		
GD350-015G/018P-45	15	40	32		
GD350-018G/022P-45	18.5	47	38	17.7	274*399*231
GD350-022G/030P-45	22	56	45		

Installation Dimensions

Wall mounting installation diagram

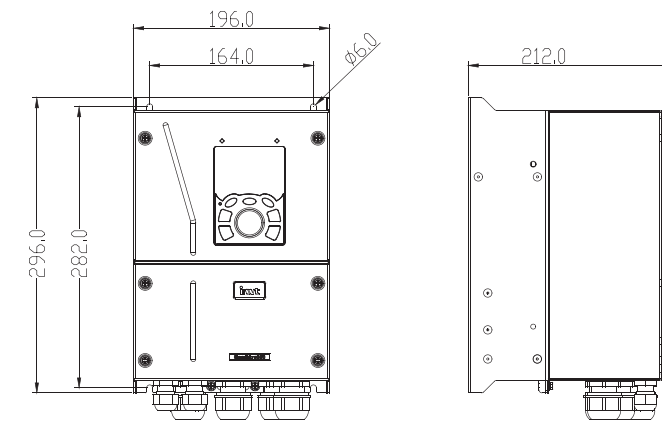

380V, 4~5.5kW

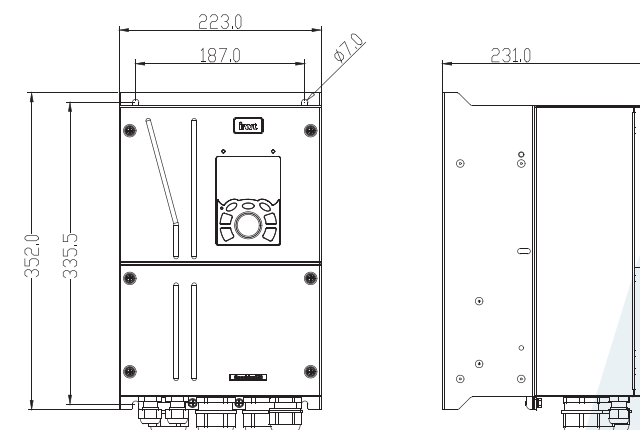

380V, 7.5~15kW

Type Selection

GD350 – 022G/030P – 4 5

① ② ③ ④

Field	Sign	Description	Contents
Abbreviation of product series	①	Abbreviation of product series	GD350: Goodrive350 high-performance multi-function VFD
Rated power	②	Power range+ Load type	022: 22kW G—Constant torque load P—Special for fans and pumps
Voltage level	③	Voltage level	4: AC 3PH 380V(-15%)—440V(+10%)
IP level	④	IP level	5: IP54

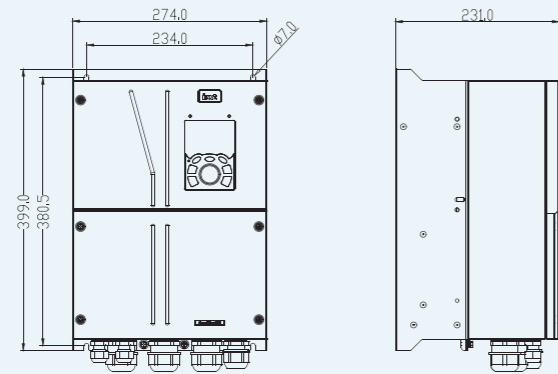

VFD specification	W1	W2	H1	H2	D1	Installation hole diameter	Fixing screw
4~5.5kW	192	164	296	282	212	6	M5
7.5~15kW	223	187	352	335.5	231	7	M6
18.5~22kW	274	234	399	380.5	231	7	M6

Flange mounting installation diagram

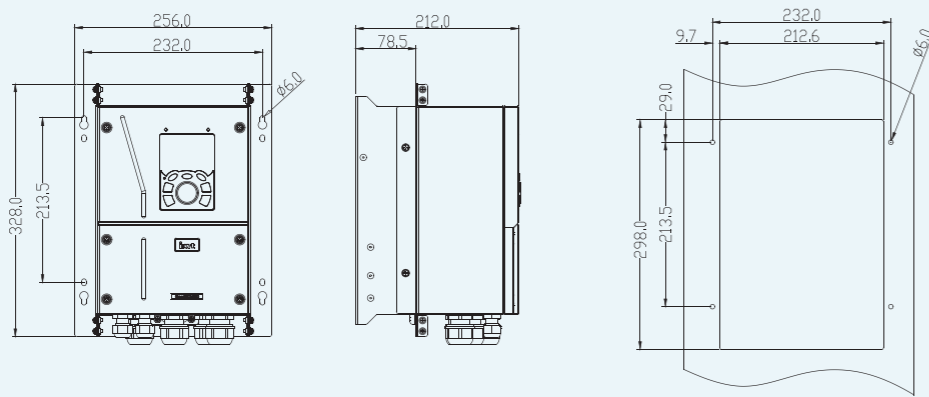

380V, 4~5.5kW

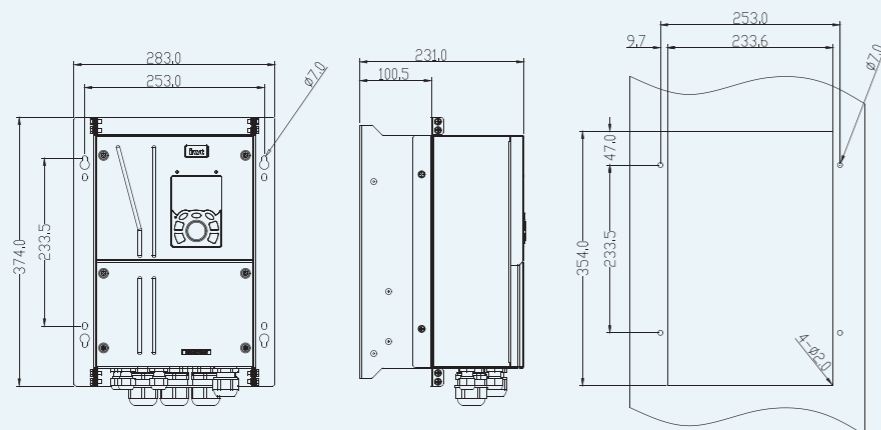

380V, 7.5~15kW

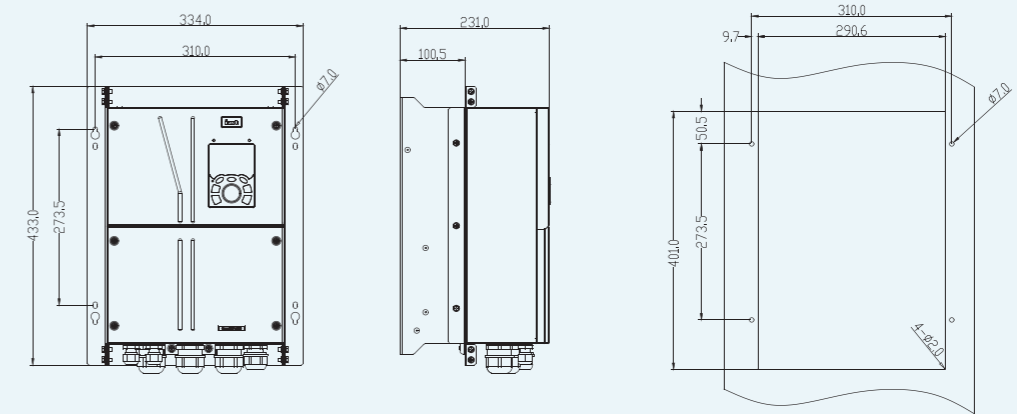

380V, 18.5~22kW

VFD specification	W1	W2	W3	W4	H1	H2	H3	H4	D1	D2	Installation hole diameter	Fixing screw
4~5.5kW	256	232	212.6	9.7	328	213.5	298	29	212	78.5	6	M5
7.5~15kW	283	253	233.6	9.7	374	233.5	354	47	231	100.5	7	M6
18.5~22kW	334	310	290.6	9.7	433	273.5	401	50.5	231	100.5	7	M6

Optional Parts

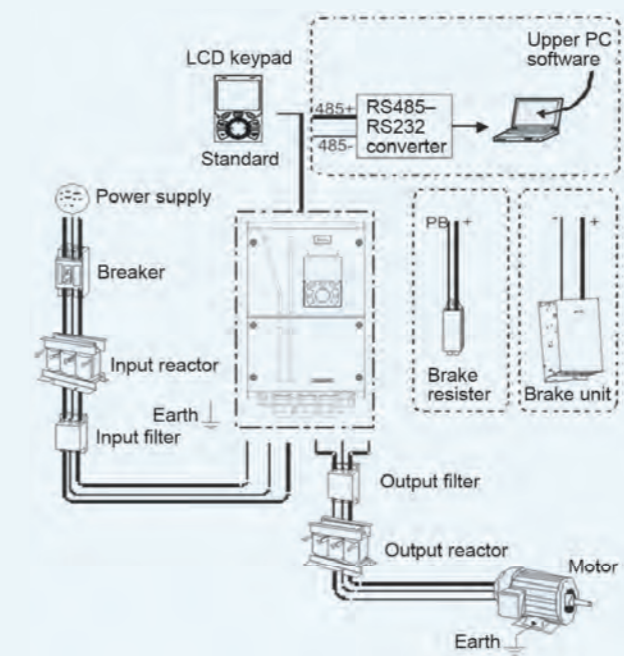

- VFDs of 380 V, 22 kW or lower are equipped with built-in brake units.
- VFDs of 380 V, 18.5 kW to 22 kW are equipped with built-in DC reactors.
- The brake units INVT's DBU series standard brake units. For details, see the DBU operation manual.

Image	Name	Description
	Cable	Accessory for signal transmission
	Breaker	Device for electric shock prevention and protection against short-to-ground that may cause current leakage and fire. Select residual-current circuit breakers (RCCBs) that are applicable to VFD and can restrict high-order harmonics, and of which the rated sensitive current for one VFD is larger than 30 mA.
	Input reactor	Accessories used to improve the current adjustment coefficient on the input side of the inverter, and thus restrict high-order harmonic currents.
	Input filter	Accessory that restricts the electromagnetic interference generated by the VFD and transmitted to the public grid through the power cable. Try to install the input filter near the input terminal side of the VFD.
	Brake unit or brake resistor	Accessories used to consume the regenerative energy of the motor to reduce the deceleration time. VFDs of 380 V, 22 kW or lower need only to be configured with brake resistors.
	Output filter	Accessory used to restrict interference generated in the wiring area on the output side of the VFD. Try to install the output filter near the output terminal side of the VFD.
	Output reactor	Accessory used to lengthen the valid transmission distance of the VFD, which effectively restrict the transient high voltage generated during the switch-on and switch-off of the IGBT module of the VFD.

Breakers and electromagnetic contactor

VFD model	Fuse (A)	Breaker (A)	Rated current of the contactor (A)
GD350-004G/5R5P-45	30	25	16
GD350-5R5G/7R5P-45	45	25	16
GD350-7R5G/011P-45	60	40	25
GD350-011G/015P-45	78	63	32
GD350-015G/018P-45	105	63	50
GD350-018G/022P-45	114	100	63
GD350-022G/030P-45	138	100	80

Reactor

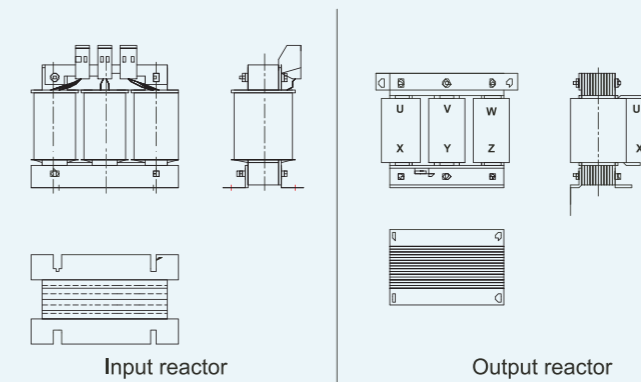

Input reactor

Output reactor

Control cables

VFD model	Recommended cable size (mm ²)		Size of connectable cable (mm ²)				Terminal screw specification	Tightening torque (Nm)
	RST UVW	PE	RST UVW	P1, (+)	PB, (+), (-)	PE		
GD350-004G/5R5P-45	2.5	2.5	2.5-6	2.5-6	2.5-6	2.5-6	M4	1.2-1.5
GD350-5R5G/7R5P-45	2.5	2.5	2.5-6	2.5-6	2.5-6	2.5-6	M4	1.2-1.5
GD350-7R5G/011P-45	4	4	2.5-6	4-6	4-6	2.5-6	M4	1.2-1.5
GD350-011G/015P-45	6	6	4-10	4-10	4-10	4-10	M5	2.3
GD350-015G/018P-45	6	6	4-10	4-10	4-10	4-10	M5	2.3
GD350-018G/022P-45	10	10	10-16	10-16	10-16	10-16	M5	2.3
GD350-022G/030P-45	16	16	10-16	10-16	10-16	10-16	M5	2.3

VFD model	Input reactor	Output reactor
GD350-004G/5R5P-45	ACL2-004-4	OCL2-004-4
GD350-5R5G/7R5P-45	ACL2-5R5-4	OCL2-5R5-4
GD350-7R5G/011P-45	ACL2-7R5-4	OCL2-7R5-4
GD350-011G/015P-45	ACL2-011-4	OCL2-011-4
GD350-015G/018P-45	ACL2-015-4	OCL2-015-4
GD350-018G/022P-45	ACL2-018-4	OCL2-018-4
GD350-022G/030P-45	ACL2-022-4	OCL2-022-4

Filters

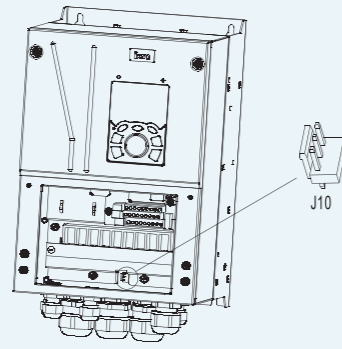

Note: Do not connect C3 filters in IT power systems.

Filter model description

FLT – P 04 045 L B

A B C D E F

Field identifier	Field description
A	FLT: Name of the VFD filter series
B	Filter type P: Power input filter L: Output filter
C	Voltage class 04: AC 3PH 380V (-15%)–440V (+10%)
D	3-digit code indicating the rated current. For example, 015 indicates 15 A.
E	Filter performance L: General H: High-performance
F	Filter application environment A: Environment Category I, C1 (EN 61800-3:2004) B: Environment Category I, C2 (EN 61800-3:2004) C: Environment Category II, C3 (EN 61800-3:2004)

VFD model	Input filter	Output filter
GD350-004G/5R5P-45	FLT-P04016L-B	FLT-L04016L-B
GD350-5R5G/7R5P-45		
GD350-7R5G/011P-45	FLT-P04032L-B	FLT-P04032L-B
GD350-011G/015P-45		
GD350-015G/018P-45	FLT-P04045L-B	FLT-P04045L-B
GD350-018G/022P-45		
GD350-022G/030P-45	FLT-P04065L-B	FLT-P04065L-B

Brake system

VFD model	Brake unit model	Resistance applicable for 100% brake torque (Ω)	Dissipated power of brake resistor (kW)			Min. allowable brake resistance (Ω)
			10% brake usage	50% brake usage	80% brake usage	
GD350-004G/5R5P-45	Built-in brake unit	122	0.6	3	4.8	80
GD350-5R5G/7R5P-45		89	0.75	4.1	6.6	60
GD350-7R5G/011P-45		65	1.1	5.6	9	47
GD350-011G/015P-45		44	1.7	8.3	13.2	31
GD350-015G/018P-45		32	2	11	18	23
GD350-018G/022P-45		27	3	14	22	19
GD350-022G/030P-45		22	3	17	26	17



- ★ INVT Headquarters
- INVT Sales & Service in 11 countries
- Sales and Service Partners in 65 countries