

### TCS-605-1 TCS-605-2 TCS-605-5

Warner Electric pivot point sensor is a precision electronic positioning device which is used with the MCS-203, MCS-207, TCS-210 or TCS-310 dancer control system to provide smooth control of unwind stands operating at any speed. The sensor is mounted at one end of the dancer roll pivot shaft where it monitors the angular position, direction of travel and relative speed of dancer arm movement. TCS-605-2 used with drive systems.

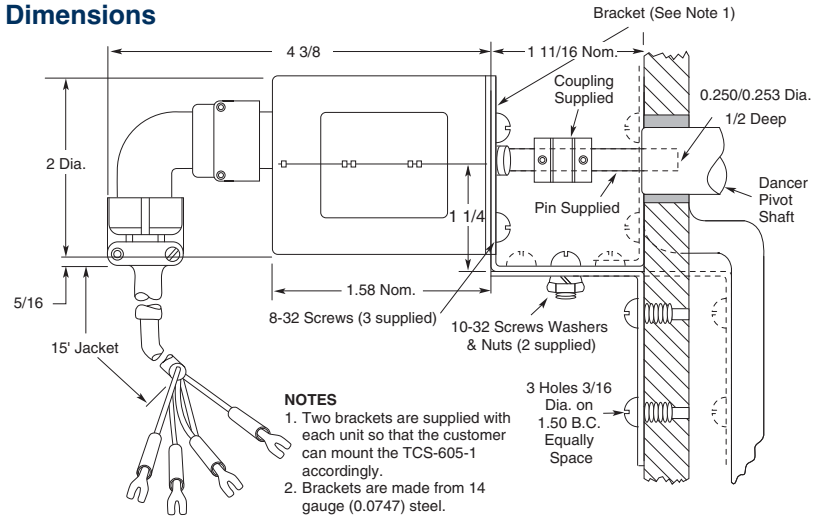

### Dimensions



### Intermittent Motion Sensor Coupling

The Intermittent Motion Sensor Coupling is a two part coupling designed for applications where the web is started and stopped by intermittent motion. The design allows for an adjustable deadband so that the dancer arm can move before motion is translated to the pivot point sensor. This allows for smoother control of the tensioning device and prevents unwanted hunting and instability in the system. If your application requires this type of coupling, contact your Warner Electric tension specialist to determine if it is right for you.

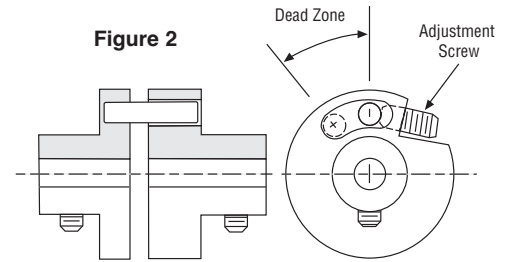
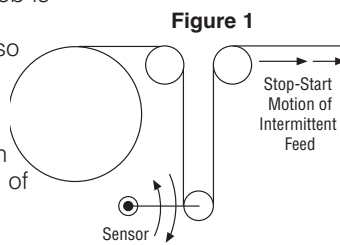

### Specifications

Model No.	Part No.	Description
TCS-605-1	7330-448-002	Single turn potentiometer for dancer arm systems where the range of rotary motion from full-up to full-down dancer position is normally maintained within 60° (1KΩ)
TCS-605-2	7330-448-004	Single turn potentiometer for drive systems (5KΩ)
TCS-605-5	7330-448-003	Five turn potentiometer for festooned dancer systems (1KΩ)
<b>Accessories</b>		
	6910-101-001	Intermittent motion sensor coupling
	284-8000-003	Coupling for Pivot Point Sensors
	7330-101-001	TCS-605 Cable Assembly Only
	7330-101-002	TCS-605-1 Sensor Assembly Only
	7330-101-003	TCS-605-5 Sensor Assembly Only