

API



Family features:

- ▶ With and without hallsensor
- ▶ Degree of protection: IP 50 A
- ▶ Operation mode: S3
- ▶ Direction of rotation: CCW/CW

	Part number	P _n (Nominal power) W	I _n (Nominal current) A	n _n (Nominal speed) rpm	M _n (Nominal torque) Ncm	M _a (Stall torque) Ncm	Signal	Dimensional drawing (D)	Wiring diagram (W)	Drive end (S)	Connector (C)	Performance curve (P)
12 V	0 130 002 632	20.2	4.8	3860	5	50	Yes	D1	W1	S1	C1	P2
	0 130 002 633	20.2	4.8	3860	5	50	No	D1	W2	S1	C1	P2
	0 130 002 613	16	4.5	3065	5	69	Yes	D2	W1	S1	C1	P6
	0 130 002 634	20	4.6	3820	5	62	Yes	D3	W1	S1	C1	P5
	0 130 002 636	16	4.5	3065	5	69	No	D2	W2	S1	C1	P6
24 V	0 130 002 681	39.5	4.5	7540	5	61	Yes	D1	W1	S1	C1	P1
	0 130 002 672	15.3	2.1	3660	4	65	Yes	D4	W3	S1	C2	P3
	0 130 002 673	16	1.9	3050	5	65	Yes	D2	W3	S1	C1	P4
	0 130 002 674	16	1.9	3050	5	65	No	D2	W4	S1	C1	P4

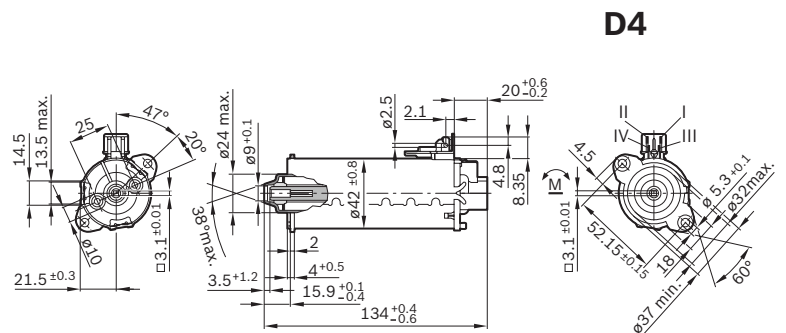
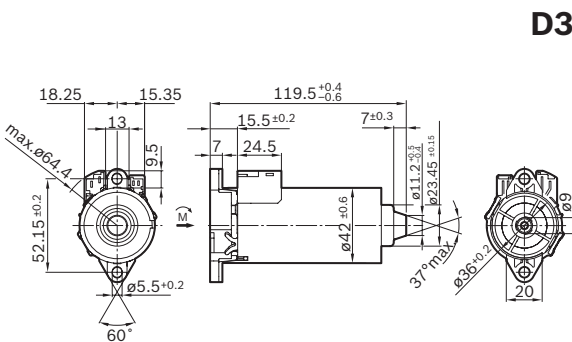
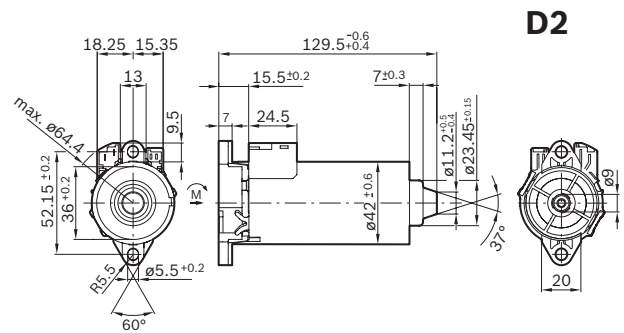
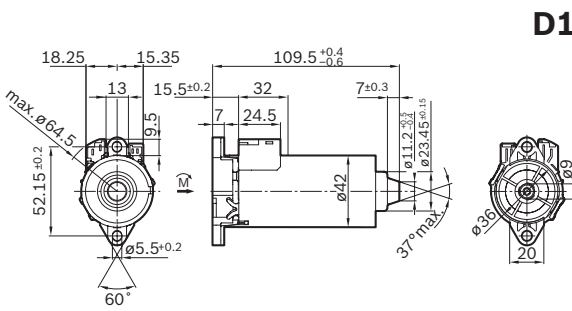

API

Wiring diagram (W)

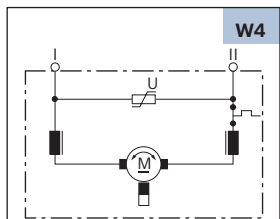
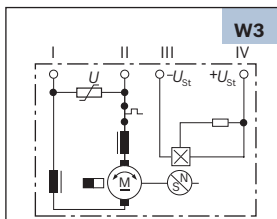
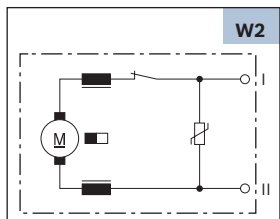
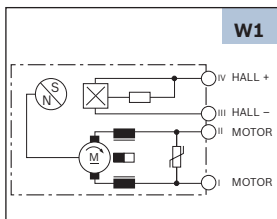

Drive end (S)

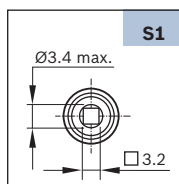

Mating connector (C)

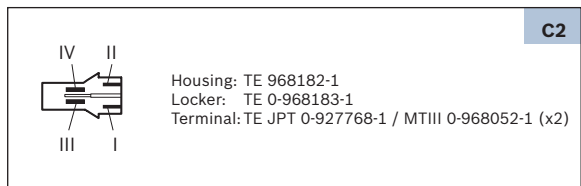
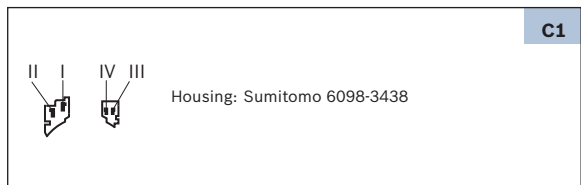

Performance curve (P)

